

# **Service Manual**

## **Agilent Technologies**

### **8757D**

## **Scalar Network Analyzer**

**Note:** The original 8757D incorporated a cathode ray tube (CRT) based display. The current design incorporates a liquid crystal display (LCD). In this manual, references to either CRT or LCD apply to both display designs unless noted otherwise.



**Manufacturing Part Number: 08757-90110**

**Printed in USA**

**Print Date: March 2005**

**Supersedes: January 2001**

© Agilent Technologies, Inc. 1992, 2001, 2005

---

## **Hewlett-Packard to Agilent Technologies Transition**

This manual may contain references to HP or Hewlett-Packard. Please note that Hewlett-Packard's former test and measurement, semiconductor products and chemical analysis businesses are now part of Agilent Technologies. To reduce potential confusion, the only change to product numbers and names has been in the company name prefix: where a product number/name was HP XXXX the current name/number is now Agilent XXXX. For example, model number HP 8757D is now model number Agilent 8757D.

---

## **Documentation Warranty**

THE MATERIAL CONTAINED IN THIS DOCUMENT IS PROVIDED "AS IS," AND IS SUBJECT TO BEING CHANGED, WITHOUT NOTICE, IN FUTURE EDITIONS. FURTHER, TO THE MAXIMUM EXTENT PERMITTED BY APPLICABLE LAW, AGILENT DISCLAIMS ALL WARRANTIES, EITHER EXPRESS OR IMPLIED WITH REGARD TO THIS MANUAL AND ANY INFORMATION CONTAINED HEREIN, INCLUDING BUT NOT LIMITED TO THE IMPLIED WARRANTIES OF MERCHANTABILITY AND FITNESS FOR A PARTICULAR PURPOSE. AGILENT SHALL NOT BE LIABLE FOR ERRORS OR FOR INCIDENTAL OR CONSEQUENTIAL DAMAGES IN CONNECTION WITH THE FURNISHING, USE, OR PERFORMANCE OF THIS DOCUMENT OR ANY INFORMATION CONTAINED HEREIN. SHOULD AGILENT AND THE USER HAVE A SEPARATE WRITTEN AGREEMENT WITH WARRANTY TERMS COVERING THE MATERIAL IN THIS DOCUMENT THAT CONFLICT WITH THESE TERMS, THE WARRANTY TERMS IN THE SEPARATE AGREEMENT WILL CONTROL.

---

## **DFARS/Restricted Rights Notice**

If software is for use in the performance of a U.S. Government prime contract or subcontract, Software is delivered and licensed as "Commercial computer software" as defined in DFAR 252.227-7014 (June 1995), or as a "commercial item" as defined in FAR 2.101(a) or as "Restricted computer software" as defined in FAR 52.227-19 (June 1987) or any equivalent agency regulation or contract clause. Use, duplication or disclosure of Software is subject to Agilent Technologies' standard commercial license terms, and non-DOD Departments and Agencies of the U.S. Government will receive no greater than Restricted Rights as defined in FAR 52.227-19(c)(1-2) (June 1987). U.S. Government users will receive no greater than Limited Rights as defined in FAR 52.227-14 (June 1987) or DFAR 252.227-7015 (b)(2) (November 1995), as applicable in any technical data.

---

---

## Printing Copies of Documentation from the Web

To print copies of documentation from the Web, download the PDF file from the Agilent web site:

- Go to <http://www.agilent.com>.
  - Enter the document's part number (located on the title page) in the **Quick Search** box.
  - Click GO.
  - Click on the hyperlink for the document.
  - Click the printer icon located in the tool bar.
-

# Contacting Agilent

This information supersedes all prior HP contact information.

**Online assistance:** [www.agilent.com/find/assist](http://www.agilent.com/find/assist)

Americas			
<b>Brazil</b> <i>(tel)</i> (+55) 11 3351 7012 <i>(fax)</i> (+55) 11 3351 7024	<b>Canada</b> <i>(tel)</i> +1 877 894 4414 <i>(fax)</i> +1 303 662 3369	<b>Mexico</b> <i>(tel)</i> 1 800 254 2440 <i>(fax)</i> 1 800 254 4222	<b>United States</b> <i>(tel)</i> 800 829 4444 <i>(alt)</i> (+1) 303 662 3998 <i>(fax)</i> 800 829 4433
Asia Pacific and Japan			
<b>Australia</b> <i>(tel)</i> 1 800 225 574 <i>(fax)</i> 1 800 681 776 <i>(fax)</i> 1 800 225 539	<b>China</b> <i>(tel)</i> 800 810 0508 <i>(alt)</i> 800 810 0510 <i>(fax)</i> 800 810 0507 <i>(fax)</i> 800 810 0362	<b>Hong Kong</b> <i>(tel)</i> 800 933 229 <i>(fax)</i> 800 900 701	<b>India</b> <i>(tel)</i> 1600 112 626 <i>(fax)</i> 1600 112 727 <i>(fax)</i> 1600 113 040
<b>Japan (Bench)</b> <i>(tel)</i> 0120 32 0119 <i>(alt)</i> (+81) 426 56 7799 <i>(fax)</i> 0120 01 2144	<b>Japan (On-Site)</b> <i>(tel)</i> 0120 802 363 <i>(alt)</i> (+81) 426 56 7498 <i>(fax)</i> (+81) 426 60 8953	<b>Singapore</b> <i>(tel)</i> 1 800 275 0880 <i>(fax)</i> (+65) 6755 1235 <i>(fax)</i> (+65) 6755 1214	<b>South Korea</b> <i>(tel)</i> 080 778 0011 <i>(fax)</i> 080 778 0013
<b>Taiwan</b> <i>(tel)</i> 0800 047 669 <i>(fax)</i> 0800 047 667 <i>(fax)</i> 886 3492 0779	<b>Thailand</b> <i>(tel)</i> 1 800 2758 5822 <i>(alt)</i> (+66) 2267 5913 <i>(fax)</i> 1 800 656 336	<b>Malaysia</b> <i>(tel)</i> 1800 880 399 <i>(fax)</i> 1800 801 054	
Europe			
<b>Austria</b> <i>(tel)</i> 0820 87 44 11* <i>(fax)</i> 0820 87 44 22	<b>Belgium</b> <i>(tel)</i> (+32) (0)2 404 9340 <i>(alt)</i> (+32) (0)2 404 9000 <i>(fax)</i> (+32) (0)2 404 9395	<b>Denmark</b> <i>(tel)</i> (+45) 7013 1515 <i>(alt)</i> (+45) 7013 7313 <i>(fax)</i> (+45) 7013 1555	<b>Finland</b> <i>(tel)</i> (+358) 10 855 2100 <i>(fax)</i> (+358) (0) 10 855 2923
<b>France</b> <i>(tel)</i> 0825 010 700* <i>(alt)</i> (+33) (0)1 6453 5623 <i>(fax)</i> 0825 010 701*	<b>Germany</b> <i>(tel)</i> 01805 24 6333* <i>(alt)</i> 01805 24 6330* <i>(fax)</i> 01805 24 6336*	<b>Ireland</b> <i>(tel)</i> (+353) (0)1 890 924 204 <i>(alt)</i> (+353) (0)1 890 924 206 <i>(fax)</i> (+353) (0)1 890 924 024	<b>Israel</b> <i>(tel)</i> (+972) 3 9288 500 <i>(fax)</i> (+972) 3 9288 501
<b>Italy</b> <i>(tel)</i> (+39) (0)2 9260 8484 <i>(fax)</i> (+39) (0)2 9544 1175	<b>Luxemburg</b> <i>(tel)</i> (+32) (0)2 404 9340 <i>(alt)</i> (+32) (0)2 404 9000 <i>(fax)</i> (+32) (0)2 404 9395	<b>Netherlands</b> <i>(tel)</i> (+31) (0)20 547 2111 <i>(alt)</i> (+31) (0)20 547 2000 <i>(fax)</i> (+31) (0)20 547 2190	<b>Russia</b> <i>(tel)</i> (+7) 095 797 3963 <i>(alt)</i> (+7) 095 797 3900 <i>(fax)</i> (+7) 095 797 3901
<b>Spain</b> <i>(tel)</i> (+34) 91 631 3300 <i>(alt)</i> (+34) 91 631 3000 <i>(fax)</i> (+34) 91 631 3301	<b>Sweden</b> <i>(tel)</i> 0200 88 22 55* <i>(alt)</i> (+46) (0)8 5064 8686 <i>(fax)</i> 020 120 2266*	<b>Switzerland (French)</b> <i>(tel)</i> 0800 80 5353 opt. 2* <i>(alt)</i> (+33) (0)1 6453 5623 <i>(fax)</i> (+41) (0)22 567 5313	<b>Switzerland (German)</b> <i>(tel)</i> 0800 80 5353 opt. 1* <i>(alt)</i> (+49) (0)7031 464 6333 <i>(fax)</i> (+41) (0)1 272 7373
<b>Switzerland (Italian)</b> <i>(tel)</i> 0800 80 5353 opt. 3* <i>(alt)</i> (+39) (0)2 9260 8484 <i>(fax)</i> (+41) (0)22 567 5314	<b>United Kingdom</b> <i>(tel)</i> (+44) (0)7004 666666 <i>(alt)</i> (+44) (0)7004 123123 <i>(fax)</i> (+44) (0)7004 444555		
<i>(tel)</i> = primary telephone number; <i>(alt)</i> = alternate telephone number; <i>(fax)</i> = FAX number; * = in country number 11/16/04			

## SAFETY CONSIDERATIONS

### GENERAL

This product and related documentation must be reviewed for familiarization with safety markings and instructions before operation. This product has been designed and tested in accordance with international standards.

### SAFETY SYMBOLS



Instruction manual symbol: the product will be marked with this symbol when it is necessary to refer to the instruction manual (refer to Table of Contents).



Indicates hazardous voltages.



Indicates earth (ground) terminal.

### WARNING

The WARNING sign denotes a hazard. It calls attention to a procedure, practice, or the like, which, if not correctly performed or adhered to, could result in personal injury. Do not proceed beyond a WARNING sign until the indicated conditions are fully understood and met.

### CAUTION

The CAUTION sign denotes a hazard. It calls attention to an operating procedure, practice, or the like, which, if not correctly performed or adhered to, could result in damage to or destruction of part or all of the product. Do not proceed beyond a CAUTION sign until the indicated conditions are fully understood and met.

### SAFETY EARTH GROUND

#### WARNING

This is a Safety Class 1 Product (provided with a protective earthing ground incorporated in the power cord). The mains plug shall only be inserted in a socket outlet provided with a protective earth contact. Any interruption of the protective conductor inside or outside of the product is likely to make the product dangerous. Intentional interruption is prohibited.

#### BEFORE APPLYING POWER

Verify that the product is configured to match the available main power source per the input power configuration instructions provided in this manual.

If this product is to be energized via an autotransformer make sure the common terminal is connected to the neutral (grounded side of the mains supply).

#### SERVICING

### WARNING

These servicing instructions are for use by qualified personnel only. To avoid electrical shock, do not perform any servicing unless you are qualified to do so.

The opening of covers or removal of parts is likely to expose dangerous voltages. Disconnect the product from all voltage sources while it is being opened.

The power cord is connected to internal capacitors that may remain live for 5 seconds after disconnecting the plug from its power supply.

For continued protection against fire hazard, replace fuse only with the same type and ratings. The use of other fuses or materials is prohibited.

## SOUND EMISSION

### Note



This statement is provided to comply with the requirements of the German Sound Emission Directive, from 18 January 1991.

This product has a sound pressure emission (at the operator position) <70 dB.

- Sound Pressure  $L_p$  <70 dB (A).
- At Operator Position.
- Normal Operation.
- According to ISO 7779 (Type Test).
- Model HP 8757D

### Note



Herstellerbescheinigung

Diese Information steht im Zusammenhang mit den Anforderungen der Maschinenlärminformationsverordnung vom 18 Januar 1991.

- Schalldruckpegel  $L_p$  <70 dB (A).
- Am Arbeitsplatz.
- Normaler Betrieb.
- Nach DIN 45635 T. 19 (Typprüfung).

# Contents

---

**NOTE** Chapter numbers are a continuation from the 8757D Scalar Network Analyzer Operating Manual.

---

## Chapter 4. Performance Tests

Introduction	4-1
Equipment Required	4-1
Self-Test	4-3
Dynamic Power Accuracy	4-4
Modulator Drive	4-5
HP Interface Bus and 8757 Interface	4-7
Performance Test Record	4-8
Performance Tests Option 002 Only	4-9

## Chapter 5. Adjustments

Introduction	5-1
Power Supply Adjustments	5-4
Sweep DAC Gain Adjustment	5-7
Display Intensity Adjustments	5-9
Nominal Intensity Adjustment	5-10
Minimum Intensity Adjustment	5-11
Vertical Position and Focus Adjustment	5-12

## Chapter 6. Replaceable Parts

Introduction	6-1
--------------	-----

## Chapter 7. Instrument History

Introduction	7-1
--------------	-----

## Chapter 8. Troubleshooting

Introduction	8-1
Self-Tests	8-5
Operator-Initiated Diagnostic Tests	8-12
Overall Instrument Description	8-18
Overall Instrument Troubleshooting	8-21
A1 Front Panel and A2 Front Panel Interface	8-31
A3 Central Processing Unit (CPU)	8-49
A4 Analog-to-Digital Converter (ADC)	8-75
A5 Modulator Driver Standard Instrument Only	8-111
A5 CAL/MOD Board Assembly Option 002 Only	8-113
A6 HP-IB Assembly	8-121
A7/A8/A9/A10 Log Amplifiers	8-133
A12 Power Supply	8-153
A11 Motherboard and A13 Rear Panel	8-169
A14 Display Interface Board	8-181
A15 Display	8-213
A16 Rear Panel Video Interface (RGB Interface)	8-217

## Manual Backdating

## Index





# Chapter 4. Performance Tests

---

## CONTENTS

- 4-1 Introduction
- 4-1 Equipment Required
- 4-1 Performance Test Record Card
- 4-3 Self-Test
- 4-4 Dynamic Power Accuracy
- 4-5 Modulator Drive
- 4-5 Voltage Amplitude
- 4-6 Frequency Accuracy and Symmetry
- 4-7 HP INTERFACE BUS and 8757 INTERFACE
- 4-9 Performance Tests (Option 002 only)

## INTRODUCTION

These procedures test the electrical performance of the HP 8757D Scalar Network Analyzer to the specifications listed in Table 1-1 of the operating manual. Access to the interior of the instrument is not required. The performance tests must be performed in the order given. If a simpler functional operation test is desired, use the "Operator's Check" in the *Operating Reference*.

Instrument dynamic accuracy measurement results depend on calibration constants stored within the instrument using the HP 11613A/B calibrator. The HP 11613A/B, used with an HP 9000 series 200 or 300 computer and HP BASIC language, calibrates the log amplifiers independently of any detectors by injecting a 27.778 kHz square wave modulated signal at different power levels. The HP 11613A/B is supplied with a calibration program stored on a 3.5 inch disk and a 5.25 inch disk. For instructions on performing the calibration constant loading procedure, refer to the *HP 11613A/B Operating and Service Manual*.

All Option 002 measurements also depend on data stored within the instrument. A program (08757-10002) executed on an external computer determines this data. The program requires the use of an HP 8902A Option 050 measurement receiver. Absolute 0 dBm reference level is set using an HP 432A power meter and an HP 487A Option H76 power sensor.

**Note:** The HP 11613A/B and the Option 002 program (08757-10002) require an external computer. The computer may be an HP 9000 series computer or a PC. See the footnotes in Table 4-1 for details.

## EQUIPMENT REQUIRED

Equipment required for the performance tests is listed in Table 4-1. Any equipment that satisfies the critical specifications given may be substituted for the recommended models. Note that the photometer is only required for the CRT display.

## PERFORMANCE TEST RECORD CARD

A performance test record card is provided at the end of this chapter for recording results of the performance tests. The specifications are listed along with space for recording actual measurements.

**Table 4–1. Recommended Test Equipment**

Instrument	Critical Specifications	Recommended Model or HP Part Number (P/N)	Use <sup>1</sup>
Sweep Oscillator	Compatible with HP 8757	HP 8350B (serial prefix 2410 or higher) or HP 8340/41 or HP 8360 series	T
RF Plug–In (with HP 8350B)	Compatible with sweep oscillator	HP 83592B (serial prefix 2502 or higher)	T
Detector	No substitute	HP 11664A (serial prefix 25000 or higher) or HP 11664E or HP 85037A/B	T
Calibrator	No substitute	HP 11613A/B	P,A,T
Oscilloscope with 10:1 Probes	Dual channel Bandwidth: $\geq 100$ MHz	HP 1740A/HP 10041A	P,T
Universal Counter	Frequency range: $\geq 1$ MHz Frequency resolution: $\leq 1$ Hz Time interval resolution: $\leq 100$ ns	HP 5316A	P,T
Digital Voltmeter	Accuracy: $\leq 0.03\%$ Resolution: $\leq 0.1$ mV Input impedance (DC): $\geq 10$ mW	HP 3456A	A,T
Power Meter with Sensor		HP 436A/HP 437B/HP 438A/HP 8481A	T
Photometer with Probe <sup>2</sup> (CRT only)		Tektronix J16/J6503	A
Adapter BNC Tee (m)(f)(f) (2 required)		HP P/N 1250–0781	P
Termination 50 ohm		HP 11593A	P
HP–IB Cable		HP 10833	P
BNC Cables (3 required)		HP P/N 8120–1839	P
VGA External Monitor	Signature analyzer clock frequency: $\geq 10$ MHz	Any compatible monitor	T
Service Kit	No substitute	HP P/N 08757–60048	T
Measuring Receiver <sup>3</sup>	No substitute	HP 8902A Option 050	P,A
Power Meter <sup>3</sup>	No substitute	HP 432A	P,A
Power Sensor <sup>3</sup>	No substitute	HP 478A Option H76	P,A
Computer used With 11613A/B	No substitute	HP 9000 Series 200/300 with Basic 5.0 or greater <sup>4</sup>	P,A
Option 002 Calibration Software	No substitute	HP P/N 08757–10002	P,A
20 dB Attenuator		HP 8491A/B Option 020	P,A

1. P=Performance Tests, A=Adjustments, T=Troubleshooting

2. Optional does not affect instrument performance. Only used for CRT display.

3. Needed for Option 002 only.

4. The computer used in conjunction with the HP 11613A/B or the program may be an HP 9000 series 200/300, or it may be a PC running HP Basic for Windows (7.0 or greater) with a GPIB card.

## **Self-Test**

### **DESCRIPTION AND PROCEDURE**

The HP 8757D is preset to initiate a built-in self-test routine. The self-test checks major parts of the analog and digital circuitry. The self-test results are displayed on the CRT. No additional equipment is required for this test.

1. Connect the analyzer (with **NO** other connections) to line power and turn the LINE switch on.
2. The self-test runs automatically and takes approximately five seconds. If the test runs successfully and passes, the graticule will appear on the display. If the self-test fails, an error or warning message will be displayed. Record PASS or FAIL on the performance test record card.

### **IF THE INSTRUMENT FAILS THIS TEST**

Refer to "Self-Test and Error Codes" in the "Troubleshooting" sections.

## Dynamic Power Accuracy

The dynamic power accuracy specification of the HP 8757D is a system level specification that depends on the detector used. To test the analyzer for dynamic power accuracy independently from any detector, use the HP 11613A/B calibrator. Follow the calibration procedure given in the *HP 11613A/B Operating and Service Manual*. **This automated procedure is the recommended method for testing dynamic accuracy and provides full analyzer traceability to NIST (formally NBS).** Using the calibrator, the entire analyzer is characterized in just a few minutes. Attach test results (graphs) for each input to the performance test record card.

### Alternative Dynamic Power Accuracy Test

A substitute dynamic accuracy test can be performed if no calibrator is available. It measures the analyzer's response to various RF input levels. This is a system level test that requires the use of a detector, 50 MHz source, and calibrated attenuators to control the RF level in precise known steps from +20 dBm to -60 dBm. This test measures to the limits of the detector's dynamic accuracy which is usually much worse than the analyzer's (it is recommended that an HP 11664A/E be used to measure the dynamic accuracy). Because this is not the recommended method for testing dynamic accuracy, no procedure is given here. Instead, the implementation of this test is left to the user. If the source has harmonic content worse than -40 dBc then a 50 MHz bandpass filter (HP p/n 08757-80027) should be used on the output of the source. The 50 MHz bandpass filter may also be ordered as part number B50-50/5-NP/N from K&L Microwave Incorporated.

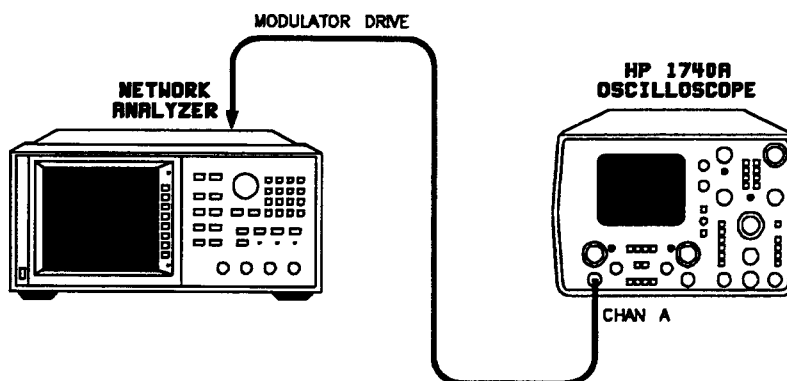
## Modulator Drive

**NOTE:** The HP 1740A Oscilloscope's 50 ohm input will dissipate 5 VRMS. If another oscilloscope is used, its 50 ohm input must be able to dissipate 3 VRMS or about 200 mW. If not, use the oscilloscope's high impedance input and externally terminate the input with a BNC tee and 50 ohm termination.

### DESCRIPTION AND PROCEDURE

The modulator drive is tested in two parts. The amplitude of the modulator drive (into 50 ohms) is checked with an oscilloscope. The frequency and symmetry of the modulator drive are measured with a universal counter.

#### Voltage Amplitude



*Figure 4-1. Voltage Amplitude Test Setup*

1. Connect the equipment as shown in Figure 4-1. Allow 30 minutes warm-up.
2. On the analyzer, press **PRESET**. The analyzer resets with modulation turned on.
3. On the oscilloscope, press DISPLAY A, TRIGGER A. Set CHAN A VOLTS/DIV to 1. Set TIME/DIV to 5 ms. Set AUTO TRIG horizontal display mode to MAIN. Set all other buttons out.

Set the oscilloscope input to GND; adjust POSN to vertically center the trace; reset the input to 50 OHM.

Adjust TRIGGER LEVEL for a stable display.

4. Compare the absolute magnitude of the positive and negative portions of the square wave to the specification. Record the smaller of the two values on the performance test record card.

## Frequency Accuracy and Symmetry

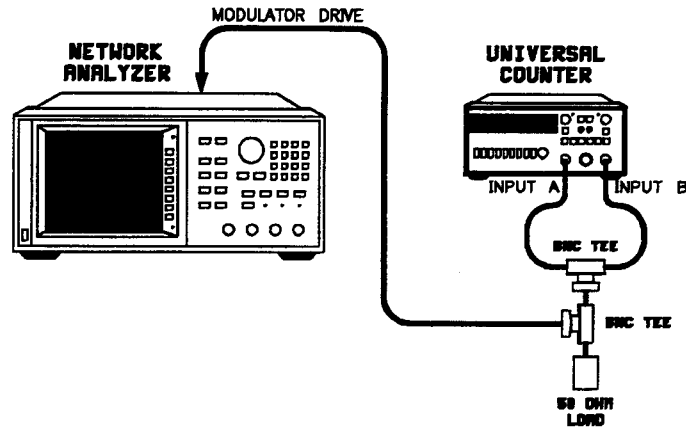


Figure 4–2. Frequency Accuracy and Symmetry Test Setup

1. Connect the equipment as shown in Figure 4–2 with no connection to the universal counter inputs A and B. Press **FREQ A** and set all other buttons out.
2. On the counter, rotate channel A LEVEL/SENS knob counterclockwise until the TRIGGER LEVEL LED lights. Rotate the knob clockwise until the LED just goes out. Repeat this procedure for channel B. This sets the trigger levels to 0.0V. Once set, do not readjust these two knobs.
3. Connect the cables from the BNC TEE to the counter inputs A and B. On the counter, set channel A to  $\_/\_$  (rising edge) and channel B to  $\_ \_$  (falling edge) to define channel A and B trigger levels.
4. Record the modulation frequency on the performance test record card and compare it to the specification.
5. Set the blue key in and select TI AVG A→B to measure the positive half cycle. Record this value on the performance test record card and compare it to the specification.
6. Reset channel A to trigger on the falling edge and channel B on the rising edge. Record this value for the negative half cycle on the performance test record card and compare it to the specification.

### IF THE INSTRUMENT FAILS THIS TEST

If the analyzer fails any part of the modulator drive test, refer to "A5 Troubleshooting."

## HP Interface Bus and 8757 Interface

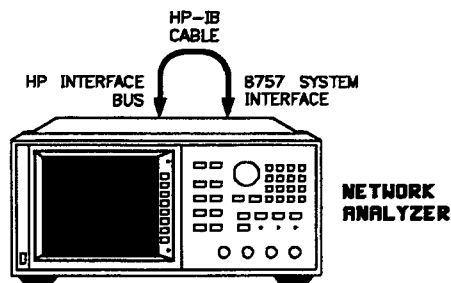


Figure 4-3. HP Interface Bus and 8757 System Interface Test Setup

### DESCRIPTION AND PROCEDURE

An HP-IB cable connects the HP INTERFACE BUS to the 8757 SYSTEM INTERFACE. Internal diagnostic routines check the ability of both ports to send and accept data. This procedure is also used as an operator's check of the remote mode.

1. Set up the equipment as shown in Figure 4-3. The HP-IB cable connects the HP INTERFACE BUS and the 8757 SYSTEM INTERFACE ports on the analyzer rear panel.
2. Press **PRESET** **SYSTEM** **MORE** **SERVICE** **A6 HPIB INSTBUS** **HP-IB TESTS** **HP-IB TALK** to run the first diagnostic test.

The HP interface bus sends test data (talks) to the 8757 system interface. When the test is successfully completed, HPIB TALK PASS is displayed on the CRT. If the test fails, other messages are displayed. Record PASS or FAIL on the performance test record card.

3. Press **HP-IB LISTEN** to run the second diagnostic test. The HP interface bus accepts test data (listens) from the 8757 system interface. When the test is successfully completed, HPIB LISTEN PASS is displayed on the CRT; other messages indicate the test failed. Record PASS or FAIL on the performance test record card.
4. Press **PRESET** or **EXIT SERVICE** to exit the diagnostic test.

### IF THE INSTRUMENT FAILS THIS TEST

If either of these tests fail, refer to "A6 Troubleshooting."

## Performance Test Record

Test	Specification	Result	Uncertainty
<b>Self Test</b>	PASS/FAIL	_____	—
<b>Logger Dynamic Power Accuracy</b>			
11613A/B Test Results (Attach printout for each input.)			
Input A	PASS/FAIL	_____	—
Input B	PASS/FAIL	_____	—
Input C (Opt 001 only)	PASS/FAIL	_____	—
Input R	PASS/FAIL	_____	—
<b>Modulator Drive</b>			
<b>Voltage Amplitude</b>			
Absolute Magnitude	$\geq \pm 2.2V$	_____	—
<b>Frequency Accuracy and Symmetry</b>			
Modulation Frequency	27.766 to 27.790 kHz	_____	.001 KHz
Positive Half Cycle	17.65 to 18.35 $\mu s$	_____	.01 $\mu s$
Negative Half Cycle	17.65 to 18.35 $\mu s$	_____	.01 $\mu s$
<b>HP INTERFACE BUS and 8757 SYSTEM INTERFACE</b>			
HPIB TALK	PASS/FAIL	_____	—
HPIB LISTEN	PASS/FAIL	_____	—
<b>Option 002 Tests Only</b>			
0 dBm Reference Output Test	-.05 to +.05 dBm	_____	.03 dB
Reference Output Dynamic Accuracy	PASS/FAIL	_____	—



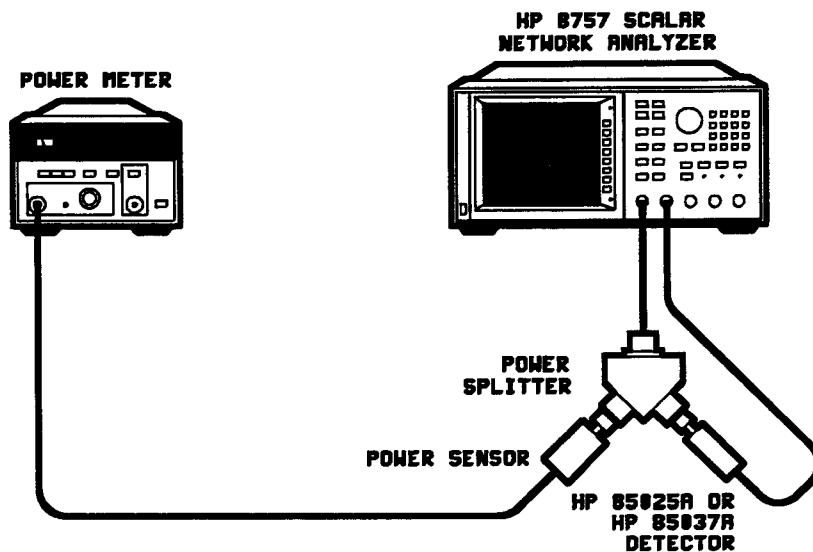
## Performance Tests Option 002 only

Option 002 instruments require two additional tests to measure both the 0 dBm reference output of the 50MHz source, and the dynamic accuracy (relative to 0 dBm) of that source from +20 to -55 dBm. These tests requires the use of an HP 8902A option 050 measurement receiver. Absolute 0dBm reference level is set using an HP 432A power meter, an HP 478A option H76 power sensor and a digital voltmeter. Both tests are automated and are available as HP p/n 08757-10002. Instructions are included.

In the event that the proper equipment and program is not available, the following manual test is available that will give a high degree of confidence that the 50 MHz reference output is functioning properly. This test will not test to specifications but will instead test to the accuracy limits of the power meter plus about 0.1dB in DC and 0.3 dB in AC mode.

Required equipment:

- HP 436A/437B/438A power meter
- HP 8481A or 8482A power sensor
- HP 8481D power sensor (for testing below -30 dBm)
- HP 11667A/B power splitter or 11636A power divider
- HP 85037A/B detector (or any AC/DC detector)



Procedure:

Allow equipment to warm up.

Properly zero and calibrate the power meter.

Connect the equipment as shown using the HP 8481A/82A sensor.

On the HP 8757D, press PRESET, channel 2, channel 2 (turns channel 2 off), SYSTEM, MORE , SWEEP MODE , CW ON, SYSTEM, MODE DC, SAVE, 1, CAL, MORE, DET OFFSET, MEAS DET OFS, DET A, 0, DBM.

At this point the analyzer is about to measure the detector at 0dBm. The power splitter will add 6.02dB of loss (assuming a perfect splitter) so the power meter should read  $-6.02\text{dBm}$ . Unfortunately, this amount of power is only present for about 1 second. In order to allow the power meter time to read properly, the 8757D must be “frozen” while it is reading the power. As soon as the START MEAS soft-key is pressed, the 8757 will display the message “Setting power”. As soon as the power has been set, it will display the message “Measuring” for about 1 second. The HP 8757D can then be “frozen” at this power level by pressing AND holding the PRESET key as soon as the analyzer displays the message “Measuring”.

Press START MEAS. Wait for the analyzer to display “Measuring” then Press and hold PRESET.

At this point the power meter will read the incident power. Verify it's accuracy. To measure more power levels:

Press RECALL, 1, CAL, MORE, DET OFFSET, MEAS DET OFS, DET A, and enter the desired power. Continue as above.

This test can also be performed in AC mode. Keep in mind that AC mode will produce a power meter reading that is lower by about 3.01 dB.

To eliminate the effects of the power splitter, delete the splitter and connect just the detector to the power cal output. Once PRESET has been pressed and while it is being held, disconnect the detector and connect the power sensor to the power cal output. Note that the actual output power may be offset by both the specified accuracy of the source plus about .03dB of DAC settability. This procedure is not meant to be a substitute for the actual automated performance test but is only meant to be a functionality test that provides a very high level of confidence.

# Chapter 5. Adjustments

---

## CONTENTS

1	Introduction
1	Safety Considerations
2	Equipment Required
2	Related Adjustments
2	Location of Test Points and Adjustment Controls
4	Power Supply Adjustments
7	Sweep DAC Gain Adjustment
9	Display Intensity Adjustments (CRT displays only)
13	Vertical Position Adjustment (CRT displays only)

## INTRODUCTION

These are the adjustment procedures for the HP 8757D Scalar Network Analyzer. Use these procedures only in the following cases:

- After replacement of an analyzer part.
- When performance tests show that the analyzer has not met the specifications of Table 1-1.
- Let the analyzer warm-up 30 minutes before performing any adjustments.

**NOTE:** This chapter covers both the CRT and LCD displays. Some display-related adjustments apply only to instruments with a CRT display.

## SAFETY CONSIDERATIONS

This product has been manufactured and tested in accordance with international safety standards. A complete list of safety considerations is provided at the front of this manual.

## WARNING

These servicing instructions are for use by qualified personnel only. To avoid electrical shock, do not perform any servicing unless you are qualified to do so.

## EQUIPMENT REQUIRED

Table 4–1 lists the equipment recommended for the adjustment procedures. If the recommended test equipment is not available, substitute other equipment only if its performance meets the critical specifications listed in the table.

## RELATED ADJUSTMENTS

Some adjustments are interactive. These are noted in the adjustment procedures. Table 5–1 lists the adjustments that must be performed if an assembly has been repaired or replaced.

## LOCATION OF TEST POINTS AND ADJUSTMENT CONTROLS

Table 5–2 lists the adjustment controls by the names that appear on the PC boards. The table also describes the function of each adjustment control. Each adjustment procedure includes a figure which shows the equipment set-up and the test points for measuring adjustment results.

*Table 5–1. Related Adjustments*

Assembly Repaired	Perform the Following Procedures and Adjustments
A1/A2 Front Panel	None
A3 CPU	Re-store calibration constants with HP 11613A/B Display Intensity Adjustments DAC ADJ Restore cal constants for calibrator if Option 002
A4 ADC	Re-store calibration constants with HP 11613A/B if any of these parts are changed: R46, R47, U5, U28, or U30.
A5 Modulator–Standard A5 Mod/Cal–Option 002 only	None Generate cal constants for internal 50 MHz calibrator using HP 8902A Option 050 with 11613A/B software.
A6 HP–IB	None
A7, A8, A9, A10 Log Amplifiers	Re-store calibration constants with the HP 11613A/B if a board is Replaced or if the following parts are changed: L1, L2, L3, CR7, CR8, U5, U7, U10, U13, VR2, any 0.1 % resistor, and any transistor.
A11 Motherboard	None
A12 Power Supply	Power Supply Adjustments
A13 Rear Panel	None
A14 Display Interface	Display Intensity Adjustments
A15 Display	Display Intensity Adjustments(CRT only) Vertical Position (if required) (CRT only)
A16 Rear Panel Video Interface	None

*Table 5-2. Adjustment Controls*

Name	Function
DAC ADJ	Adjusts sweep DAC gain for —10.2375 V dc
+15 V	Adjusts instrument +15 V power supply
—15 V	Adjusts instrument —15 V power supply
+5 DSP	Adjusts display +5 V power supply
+5 DIG	Adjusts instrument +5 V power supply
—12.6	Adjusts —12.6 V power supply

## ADJUSTING CALIBRATION CONSTANTS

Generation of calibration constants is an adjustment that can only be performed with a computer. Cal constants are stored in EEPROM's located on the A3 CPU board. These cal constants serve two major functions. The first is to correct the response of the three (four in option 001) logger boards which provides the 8757 with its high dynamic accuracy. The second function is to provide correction constants for the built-in option 002 50 MHz calibrator.

Periodic regeneration of these constants may be necessary to correct for drift and aging in the associated circuitry. Repair or replacement of either any of the logger boards, or the option 002 A5 mod/cal board will require the regeneration of cal constants.

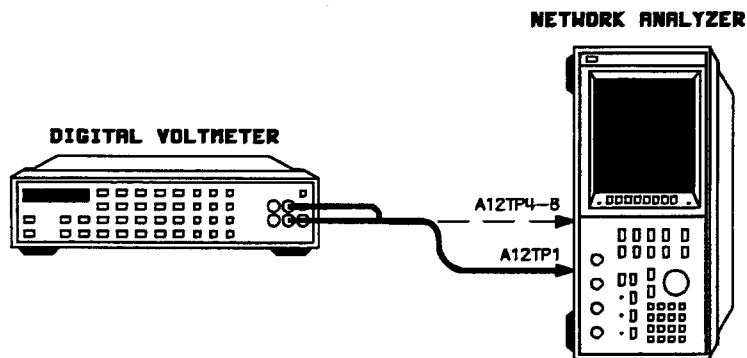
**NOTE:** Replacement of the A3 board also necessitates the regeneration of these cal constants. Although not highly recommended, if the proper equipment to regenerate cal constants is not available, it is possible to unsolder the EEPROM's from the old board and install them onto the replacement board. Ensure the IC's are re-installed in the respective locations and follow proper anti-static procedures.

The program for generating the cal constants is the same as that used for performance testing the instrument. In this program you are asked if you wish to verify existing cal constants (a performance test), or if you wish to generate new cal constants (an adjustment). Cal constants for either the logger boards or the option 002 A5 board can be generated independently of each other. Follow the procedure in the performance section of this manual.

## Power Supply Adjustments

### DESCRIPTION AND PROCEDURE

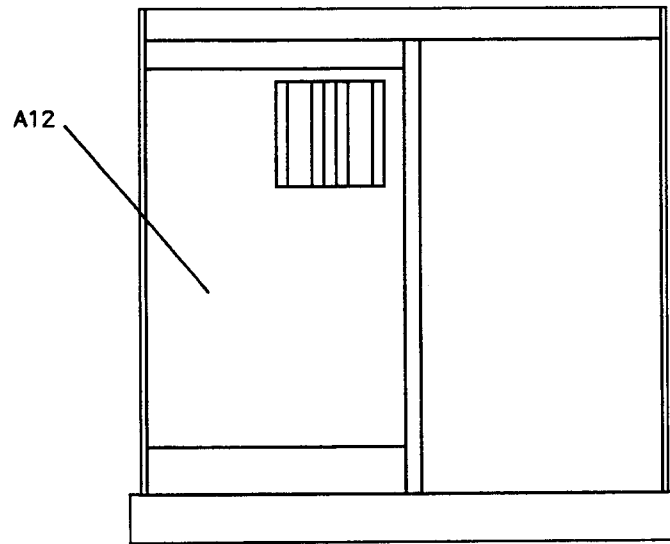
The display and instrument power supplies are adjusted on the A12 board for proper voltage levels.



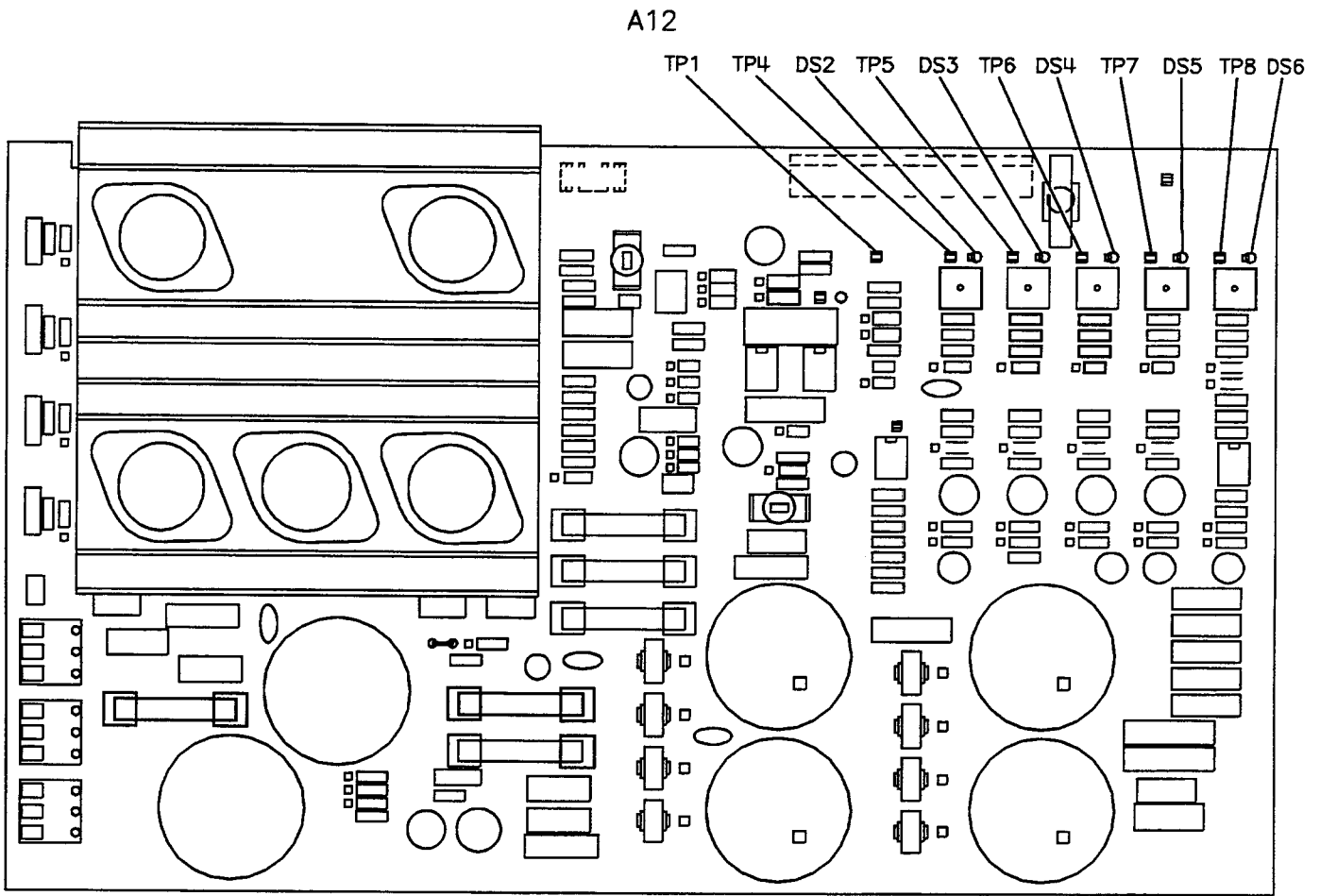
*Figure 5-1. Power Supply Adjustments Set-up*

1. Set the analyzer LINE switch to ON. Allow 30 minutes warm-up time.
2. Position the analyzer on its side (see Figure 5-1). Remove the analyzer bottom cover by removing the screw from the center of the rear portion of the cover (beneath the fan). Slide the bottom cover off.
3. Connect the equipment as shown in Figure 5-1 with DVM LO connected to A12TP1 (GND). Figure 5-2 shows the location of the A12 PC board in the analyzer and Figure 5-3 shows the adjustment locations on the A12 PC board.
4. Connect DVM HI to A12TP5 (+5V DSP). DS3, a green LED, should be lit. Adjust R44 for a DVM reading of  $+5.10 \pm 0.05$  V dc.
5. Connect DVM HI to A12TP4 (+5V DIG). DS2, a green LED, should be lit. Adjust R37 for a DVM reading of  $+5.10 \pm 0.05$  V dc.
6. Connect DVM HI to A12TP6 (+15 V). DS4, a green LED, should be lit. Adjust R51 for a DVM reading of  $+15.00 \pm 0.05$  V dc.
7. Connect DVM HI to A12TP7 (—15V). DS5, a green LED, should be lit. Adjust R58 for a DVM reading of  $-15.00 \pm 0.05$  V dc.
8. Connect DVM HI to A12TP8 (—12.6). DS6, a green LED, should be lit. Adjust R65 for a DVM reading of  $-12.60 \pm 0.05$  V dc.
9. If no further access to the interior of the analyzer is required, replace the bottom cover by reversing step 2.

**BOTTOM VIEW**



*Figure 5-2. A12 Assembly Location*



*Figure 5-3. Power Supply Adjustment Locations*



# Sweep DAC Gain Adjustment

## DESCRIPTION AND PROCEDURE

The sweep DAC gain is adjusted on the A4 board to exactly 2.5 mV per bit. This causes the 0 to —10V sweep ramp to exactly fill the CRT.

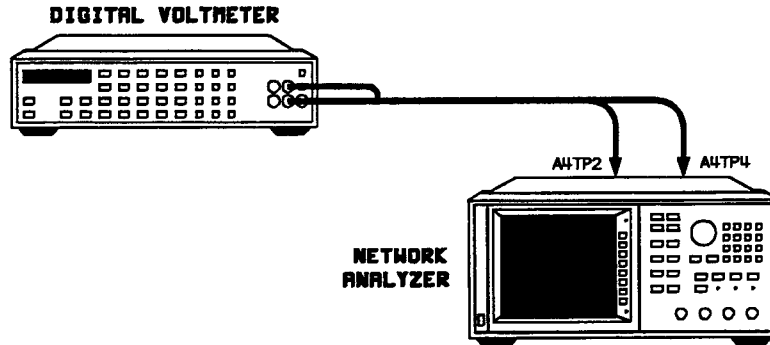
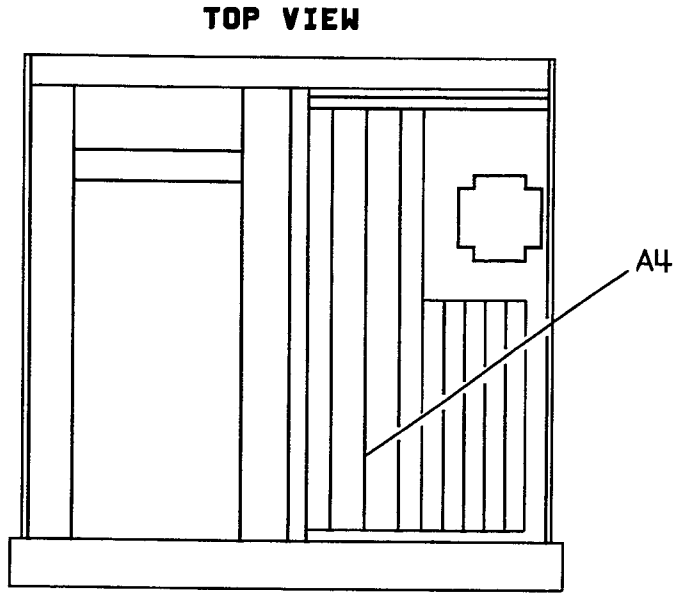


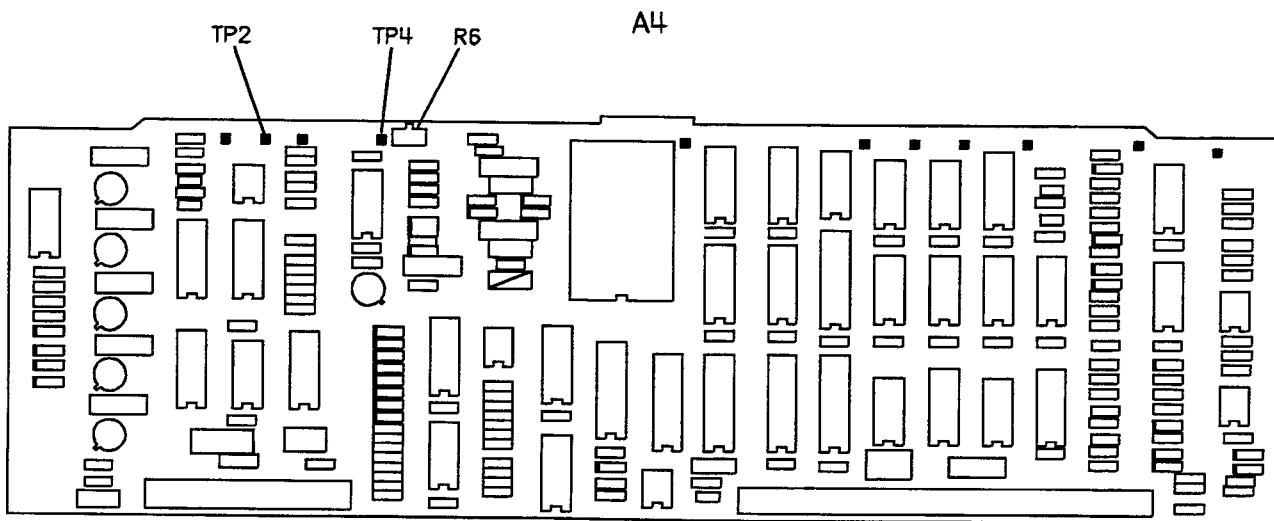
Figure 5-4. Sweep DAC Gain Adjustment Set-up

1. Set the analyzer LINE switch to ON. Allow 30 minutes warm-up time.
2. Remove the analyzer top cover by removing the screw in the center of the rear portion of the cover (above the fan). Slide the cover off.
3. Connect the equipment as shown in Figure 5-4. The test points and adjustment control are accessible without removing the logger cover. Figure 5-5 shows the location of the A4 ADC assembly and Figure 5-6 shows the adjustment locations on the A4 assembly.
4. Connect DVM LO to A4TP4 (AGND) and DVM HI to A4TP2 (DAC).
5. Press **PRESET** on the analyzer.
6. Note the maximum SWEEP DAC VOLTAGE (approximately 0.0 V) indicated on the DVM by pressing **SYSTEM MORE SERVICE A4 ADC MORE CHANNEL VOLTS CHANY OTHER SWP DAC MAX**.
7. Note the minimum SWEEP DAC VOLTAGE on the DVM by pressing **SWP DAC MIN**. The difference between this value and the value noted in step 6 should be  $-10.2375 \pm 0.0005$  V dc. If not, adjust R6 (DAC ADJ) to bring the difference within specification.
8. Note the maximum SWEEP DAC VOLTAGE on the DVM again by pressing **SWP DAC MAX**. Repeat step 7 and either confirm that the difference is now  $-10.2375 \pm 0.0005$  V dc or repeat steps 7 and 8 until that difference is attained.

9. If the analyzer cannot be adjusted to the specifications in this procedure, see "In Case of Difficulty" in Chapter 3.
10. If no further access to the interior of the analyzer is required, replace the top cover by reversing step 2.



*Figure 5-5. A4 Assembly Location*



*Figure 5-6. Sweep DAC Gain Adjustment Locations*

## Display Intensity Adjustments

These procedures are a set of 3 display intensity adjustments. Perform these procedures consecutively if they are required (usually after the A3, A14, or A15 assemblies have been replaced). These adjustments are for cosmetic purposes only and do *not* affect the analyzer usability or calibration.

**NOTE:** The following adjustments should only be performed on a CRT based display.

### Background Adjustment

#### DESCRIPTION AND PROCEDURE

The background adjustment sets the black level of the display. It is set so that the minimum intensity that can be drawn is just visible when the display is located in a dimly lit room or shaded from bright lights.

**NOTE:** This is the first in a series of three Display Intensity Adjustments. No additional equipment is needed for this first adjustment.

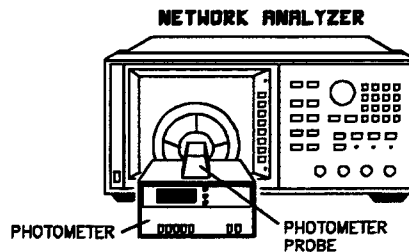
1. On the analyzer, remove the top cover by removing the screw in the center rear portion of the cover (above the fan). Slide the cover off.
2. Set the analyzer LINE switch to ON and allow 30 minutes warm-up.
3. In a dimly lit room (or with the analyzer CRT shaded from bright lights, press **PRESET** **SYSTEM** **MORE SERVICE** **DISPLAY** **BCKGRND ADJUST**. Alternating vertical bars of three different intensities will be drawn on the CRT. Each bar has a number written below it (either 0, 1, or 2).
4. Adjust the analyzer front panel knob until the vertical bar labeled "1" is just barely visible against the black border. Vertical bar "0" must not be visible.
5. On the analyzer, press any softkey. The current DAC value (Background Level) is shown on the CRT. Close switch A3S1-E, labeled WR PROTECT, to disable write protection (move the switch to the left). The switch is accessible without removing the logger cover.
6. On the analyzer, press **SAVE VALUE**. The value is saved in EEROM and you are returned to the previous menu.
7. This completes the first in a series of three Display Intensity Adjustments. Do not replace the analyzer's top cover; do not open switch A3S1-E. Proceed to "Nominal Intensity Adjustment".

## Nominal Intensity Adjustment

### DESCRIPTION AND PROCEDURE

This procedure adjusts the nominal intensity level of the display. The 100% level display intensity is set to 100 nits using a photometer to measure the output light. This adjustment does *not* change the intensity of the light output from the display; it is still capable of the same minimum and maximum intensity values. This adjustment ensures that the light output at the 100% intensity level is equal to 100 nits.

**NOTE:** This is the second in a series of three Display Intensity Adjustments. The analyzer 30 minute warm-up is already complete. The DISPLAY menu is active on the CRT.



*Figure 5-7. Nominal Intensity Adjustment Set-up*

1. Set the photometer probe to NORMAL. Press **POWER** on the photometer to turn it on and allow 30 minutes warm-up. Zero the photometer according to the manufacturer's instructions.
2. On the analyzer, press **NOMINAL INT ADJ**.
3. Center the photometer on the analyzer CRT as shown in figure 5-7. Adjust the analyzer front panel knob until the photometer registers 100 cd/m<sup>2</sup> NITS of output light if the glass bezel assembly is *not* installed. Adjust for 60 nits if the glass bezel *is* installed (the glass filter transmits 60% of the light).
4. On the analyzer, press any softkey. The current DAC value (Normal Intensity Level) is shown on the CRT. 0 =full intensity; 255 =minimum.
5. On the analyzer, press **SAVE VALUE**. The value is saved in EEROM and you are returned to the previous (DISPLAY) menu.
6. This completes the second in a series of three Display Intensity Adjustments. Do not replace the analyzer's top cover; do not open switch A3S1-E. Proceed to "Minimum Intensity Adjustment".

## Minimum Intensity Adjustment

### DESCRIPTION AND PROCEDURE

This adjustment sets the default level of minimum display intensity. The analyzer normally presets and powers on to the same intensity level that was last used. However, if the last used intensity level was set below the minimum display intensity, the analyzer will default to the minimum display intensity to ensure that the display is visible and eliminate concern that the display may not be functioning.

**NOTE:** This is the third in a series of three Display Intensity Adjustments. The analyzer and photometer 30 minute warm-up is already complete. The DISPLAY menu is active on the CRT.

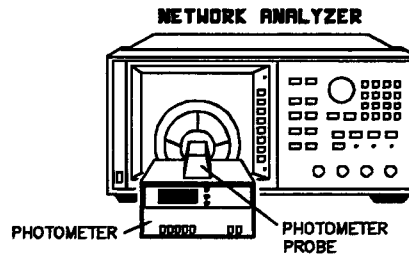


Figure 5–8. Minimum Intensity Adjustment Set-up

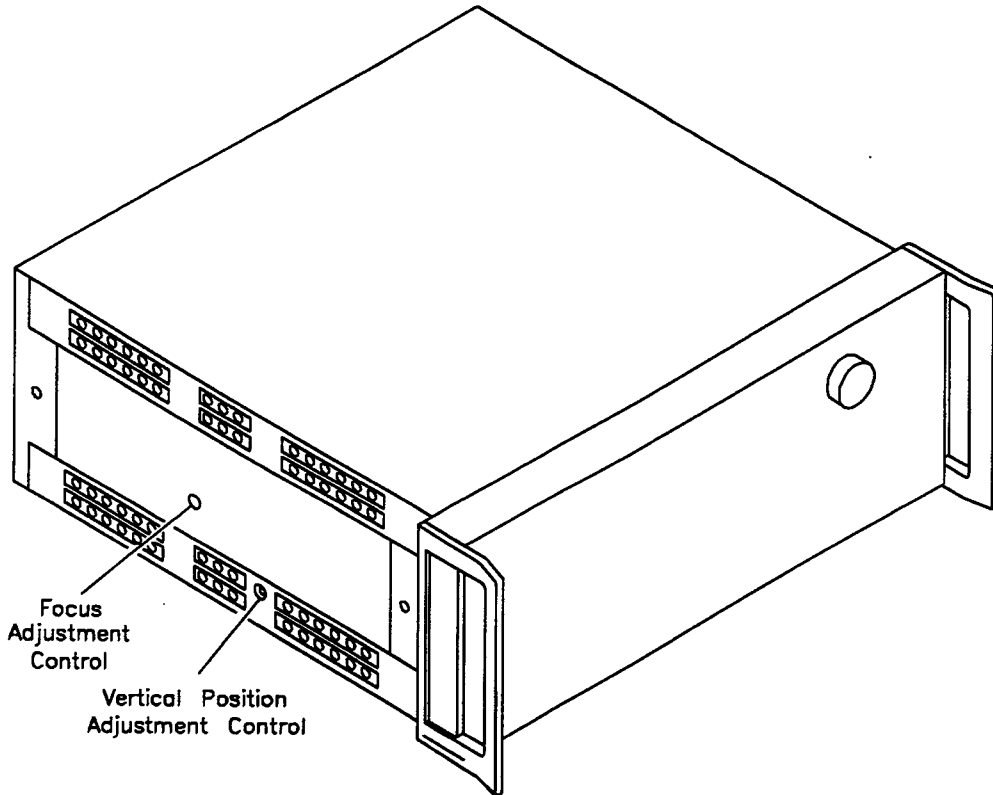
1. On the analyzer, press **MINIMUM INT ADJ**.
2. Center the photometer on the analyzer CRT as shown in figure 5–8. Adjust the analyzer front panel knob until the photometer registers 20 cd/m<sup>2</sup> NITS of output light if the glass bezel assembly is *not* installed. Adjust for 12 nits if the glass bezel *is* installed.
3. On the analyzer, press any softkey. The current DAC value (Normal Intensity Level) is shown on the CRT. 0 =full intensity; 255 =minimum.
4. On the analyzer, press **SAVE VALUE**. The value is saved in EEROM and you are returned to the previous (DISPLAY) menu.
5. This completes the series of three Display Intensity Adjustments. Open switch A3S1–E (move the switch to the right.) If no further access to the interior of the analyzer is required, replace the top cover by sliding the cover onto the instrument and replacing the screw in the center of the rear portion of the cover (above the fan).

## Vertical Position and Focus Adjustment

**NOTE:** The following adjustments should only be performed on a CRT based display.

### DESCRIPTION AND PROCEDURE

This procedure adjusts the display vertical position and focus. It may be necessary to perform this adjustment if the A15 Display is replaced. No additional equipment is required.



*Figure 5–9. Vertical Position Adjustment Control*

1. Set the analyzer LINE switch to ON. Allow 30 minutes warm-up time.
2. Remove the analyzer's left side cover next to the display. Remove the screw from the side cover and slide the cover off. Figure 5–9 shows the location of the adjustment control.
3. Insert a narrow, (preferably non-conductive) flat-head screwdriver (at least 2 inches long) into the hole in the lower corner strut that lines up with the hole in the display. This is the eighth hole from the front of the analyzer.
4. Adjust the control until the softkey labels are aligned with the softkeys.
5. Insert the flat-head screwdriver into the focus adjustment control (Figure 5–9). Adjust the focus while viewing test pattern number 10.

6. Replace the side cover by sliding it back on and replacing the screw in the cover at the rear of the instrument.





# Chapter 6. Replaceable Parts

---

---

## **INTRODUCTION**

This chapter includes lists of replaceable parts for the 8757D. To order replaceable parts refer to table “Agilent Technologies Sales and Service Offices,” at the beginning of this manual.

Tables 6-2 and 6-3 located at the end of this chapter are for reference only. The part numbers have not been updated since the 1992 edition of this manual. This information may be useful, but it not up to date.

---

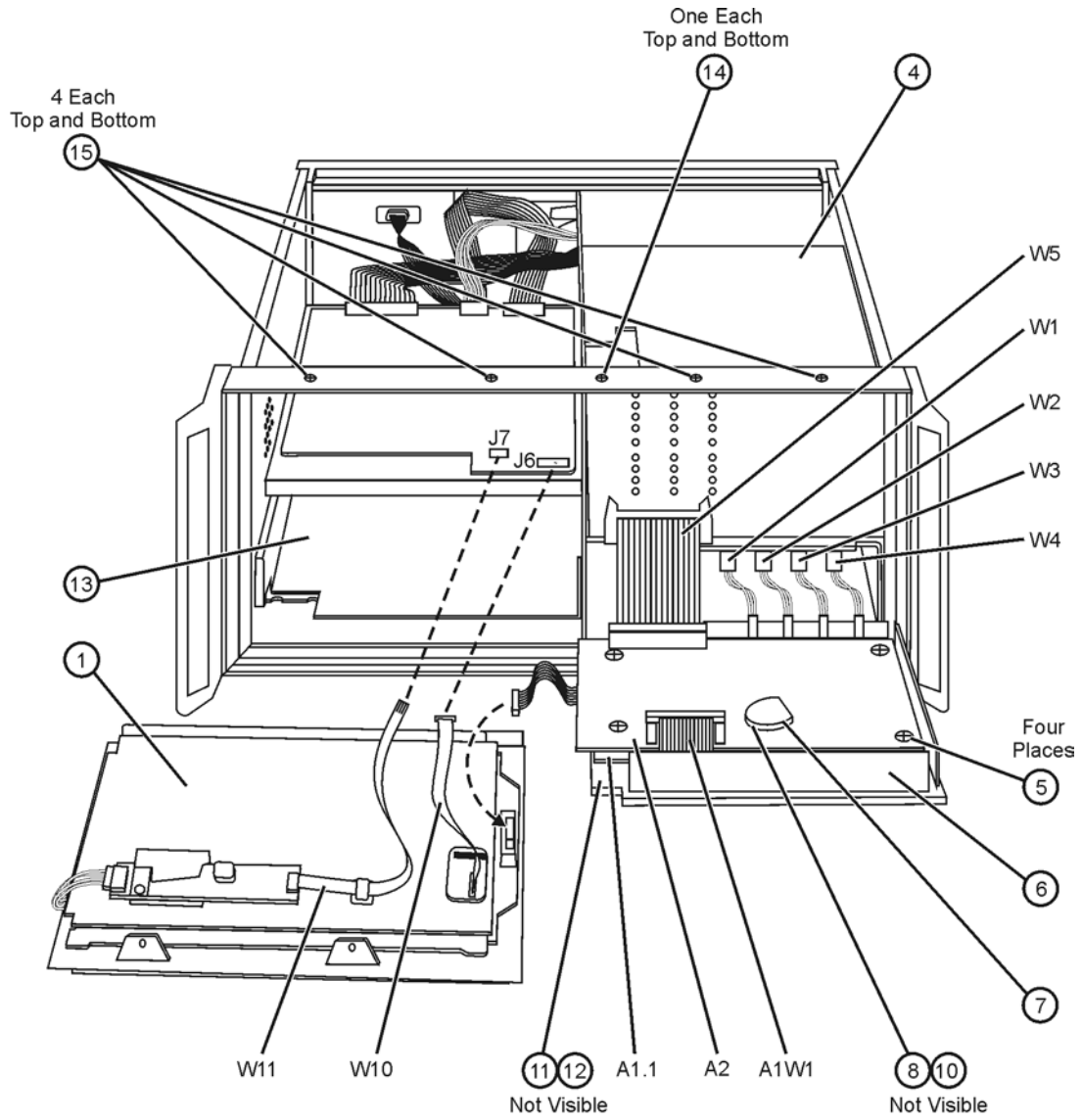
## RESTORED EXCHANGE ASSEMBLIES

Some replacement parts are available as either new or restored assemblies. The restored assembly is more economical than a new assembly and, as with new assemblies, a 90-day warranty applies through the instrument's support life. The defective assembly must be returned for credit (after you receive the replacement). For this reason, new assemblies must be ordered for spare parts. The part numbers for both new and restored assemblies are given in Table 6-1.

**Table 6-1. Restored Exchange Assemblies**

<b>Reference Designator</b>	<b>New Part Number</b>	<b>Restored Exchange Part Number</b>	<b>Description</b>
A7, A8, A9, A10	08757-60146	08757-69146	Log Amplifier
A5 (Opt. 002 only)	08757-60111	08757-69111	Mod/Cal Opt. 002

**Figure 6-1. Front View Interior**

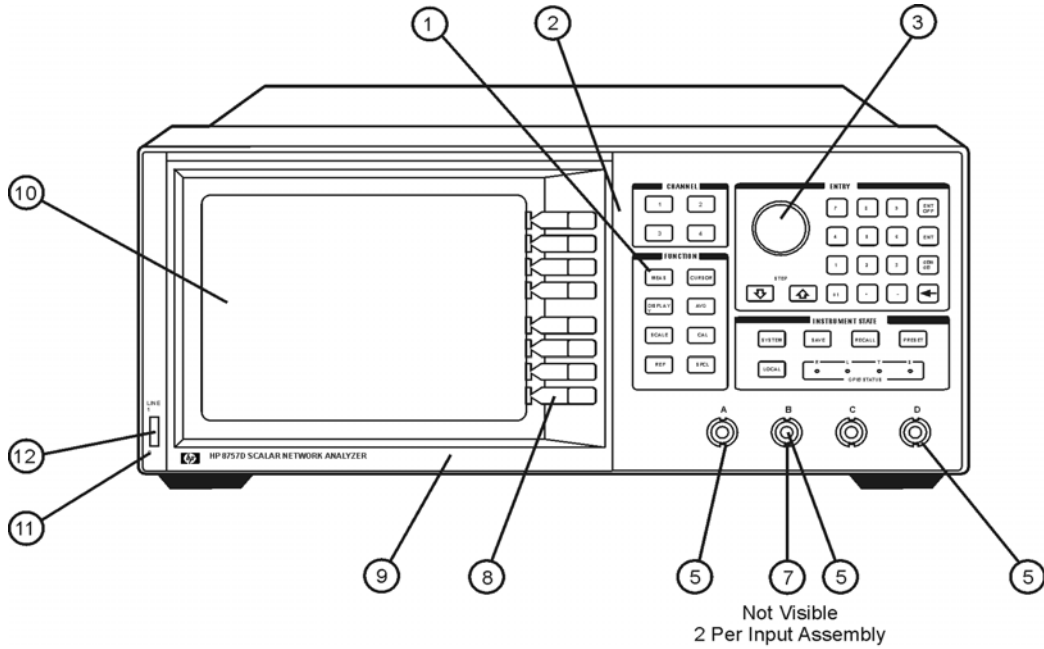


sa61d

Reference Designation	Agilent Part Number	Qty	Description
1	08757-60151	1	DISPLAY FRONT PANEL ASSY <sup>a,b</sup>
	0950-3379	1	INVERTER
	8121-0576	1	CABLE, LCD DATA
	8120-8842	1	CABLE, INVERTER
	08757-40018	1	SOFT KEYPAD
	2090-0386	1	BACKLIGHT LAMP
	1000-0095	1	DISPLAY GLASS
	08757-00061	1	LCD RETAINER (SHEET METAL)
W10	8120-0576	1	CABLE, DATA FOR LCD
W11	8120-8842	1	CABLE, INVERTER, FLAT FLEX
4	08757-00056	1	LOGGER COVER
5	0515-1410	4	SCREW SMM3.0 20 CWPNTX
6	08757-00071	1	FRONT SUBPANEL
7	1990-1525	1	RPG ASSEMBLY
8	2190-0104	1	WSHR INKL .439ID
10	2950-0043	1	NUT-HEX-DBL-CHAM 3/8-32-THD .094-IN-THK
11	08757-40017	1	MAIN KEYPAD-RUBBER
12	0515-0374	6	SCREW SMM3.0 10 CWPNTX
13	08757-00072	1	CHASIS DISPLAY INTERFACE MOUNT (SHEET METAL)
14	0515-2086	2	SCREW SMM4.0 7 PCFLT
15	0515-1382	8	SCREW SMM3.5 6 PCFLT
A1.1	08757-60149	1	KEYBOARD
A2	08757-60113	1	KEYPAD INTERFACE
A1W1	08757-60045	1	KEYBOARD/INTERFACE CABLE
W1-W4	08757-60034	1	DETECTOR INTERFACE CABLE
W5	8120-4112	1	FRONT PANEL INTERFACE CABLE

- a. When it is necessary to replace the bezel or the LCD display, replace the complete display front panel assembly (08757-60151). The bezel and LCD parts should not be replaced individually because of gaskets requiring special handling. See the A15 section of Chapter 8 for more information.
- b. The indented parts are included in the display front panel assembly (08757-60151).

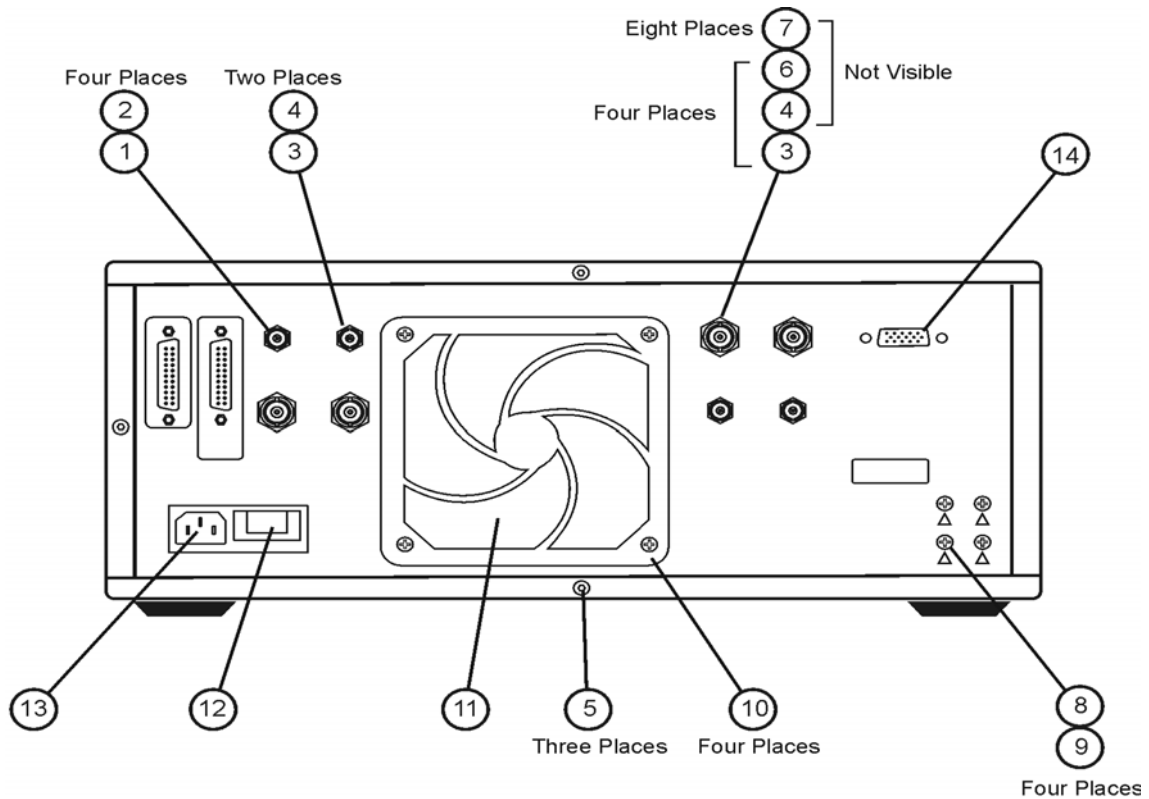
**Figure 6-2. Front View**



sa611d

Reference Designation	Agilent Part Number	Qty	Description
1	08757-40017	1	MAIN KEYPAD-RUBBER
2	08757-80084	1	FRONT PANEL LABEL (STANDARD)
	08757-80085	1	FRONT PANEL LABEL OPTION 001
	08757-80086	1	FRONT PANEL LABEL OPTION 002
	08757-80083	1	FRONT PANEL LABEL OPTION 001/002
3	01650-47401	1	KNOB-BASE 1 1/8 JGK
5	08757-60034	4	P/O DETECTOR INTFC ASSY
7	0535-0031	8	NUT M-HXSEM M3.0
8	08757-40018	1	SOFT KEYPAD-RUBBER
9	08757-80099	1	NAME PLATE LABEL
10	08757-60151	1	DISPLAY FRONT PANEL ASSY
11	08757-80098	1	LABEL, POWER SWITCH
12	08757-40005	1	LINE BUTTON

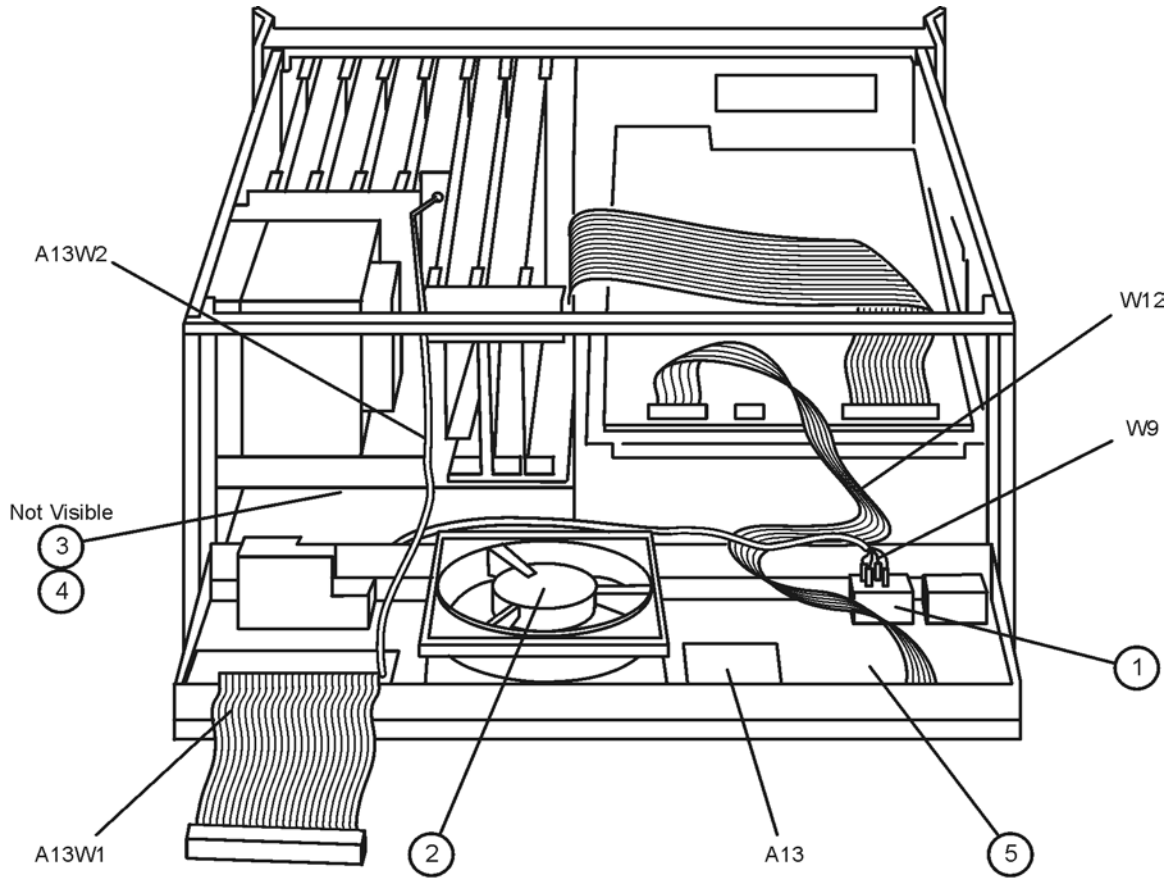
**Figure 6-3. Rear View**



sa62d

Reference Designation	Agilent Part Number	Qty	Description
1	0380-0643	4	STANDOFF-HEX .255-IN-LG 6-32THD
2	2190-0017	4	WASHER-LK HLCL N0.8 .168-IN-ID
3	2950-0035	5	NUT-HEX-DBL-CHAM 15/32-32-THD
4	2190-0102	5	WASHER-LK INTL T 15/32 IN .472-IN-ID
5	0515-1245	3	SCREW-SPCL M3.5 X 0.6 12MM-LG
6	3050-1094	4	WASHER-FL MTLC 1/2 IN .505-IN-ID
7	5040-8857	8	WASHER-SHOULDER
8	0624-0324	4	SCREW-TPG 4-20 .312-IN-LG PAN HP-POZI
9	3050-0891	4	WASHER-FL MTLC 3.0MM 3.3-MM-ID
10	0515-2041	4	SCREW SMM3.5 25 PCFLT
11	3150-0484	1	FILTER/GUARD/RETAINER-FAN
12	2110-0083	1	FUSE (INCH) 2.5A 250V NTD FE UL
	2110-0043	1	FUSE (INCH) 1.5A 250V NTD FE UL
13	0960-0443	1	LINE MODULE-FILTERED
14	8120-6876	1	VGA CONNECTOR AND CABLE
	1251-7812	1	JACKSCREW

**Figure 6-4. Rear View Interior**

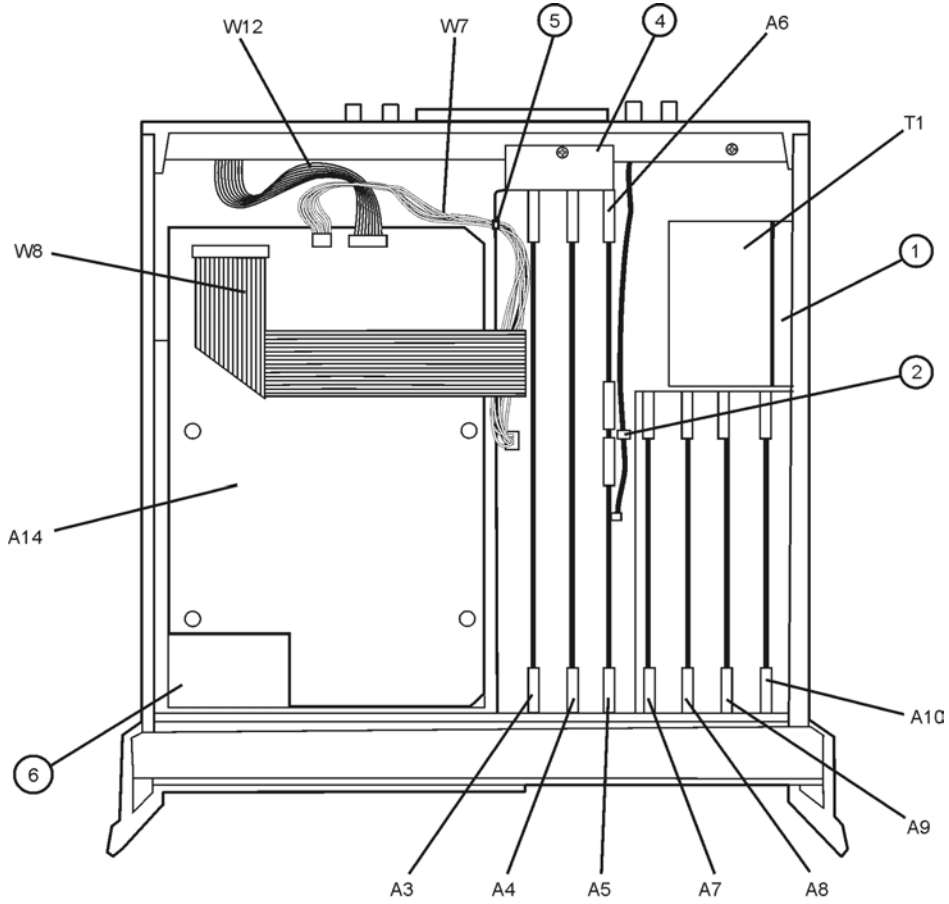


sa63d

Reference Designation	Agilent Part Number	Qty	Description
1	3101-2780	1	SWITCH DPST (PART OF W9)
2	08757-20083	1	FAN-MODIFIED
3	1251-3967	1	CONTACT-CONN U/W-POST-TYPE FEM CRP
4	1251-4933	1	CONN-POST TYPE 2.5-PIN-SPCG 3-CONT
A13	08757-60013	1	REAR PANEL ASSEMBLY
A13W1	08757-60029	1	REAR PANEL/MOTHERBOARD CABLE
A13W2	08757-60044	1	REAR PANEL/MODULATOR BOARD CABLE
W9	08757-60033	1	POWER CABLE ASSY (WITH SWITCH)
5	08757-00074	1	REAR PANEL (SHEET METAL) WITH LABEL
W12	8120-6876	1	VGA CONNECTOR AND CABLE
	1251-7812	2	JACKSCREW (USED WITH VGA CONNECTOR)



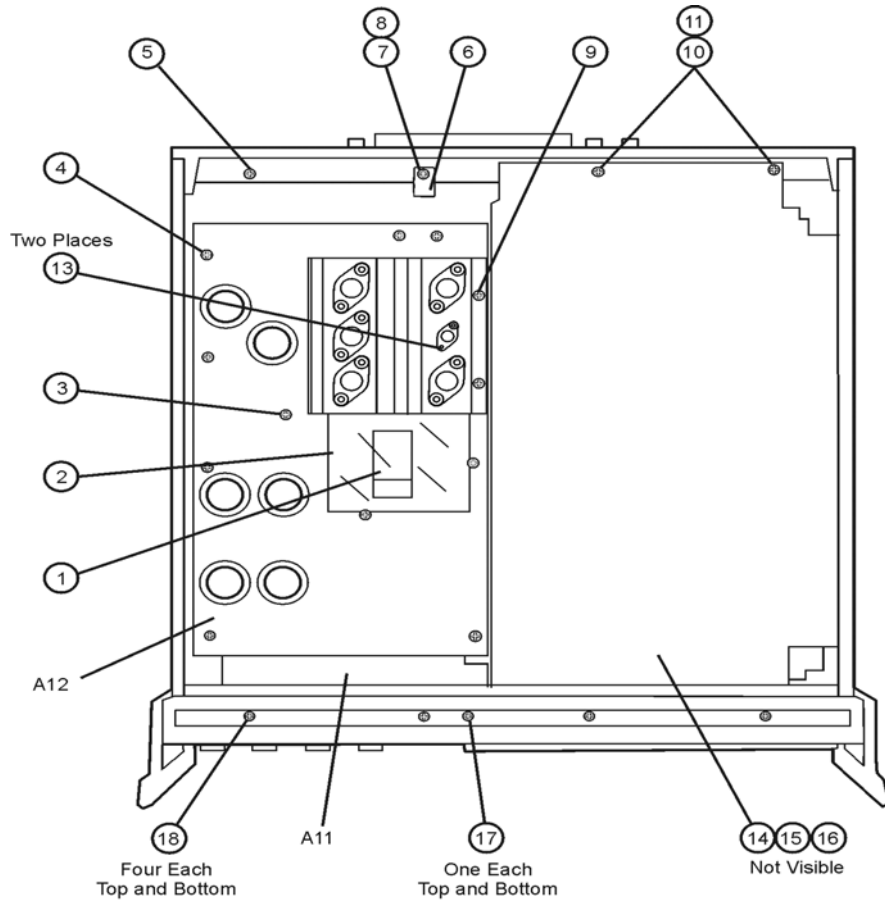
**Figure 6-5. Top View**



sa64d

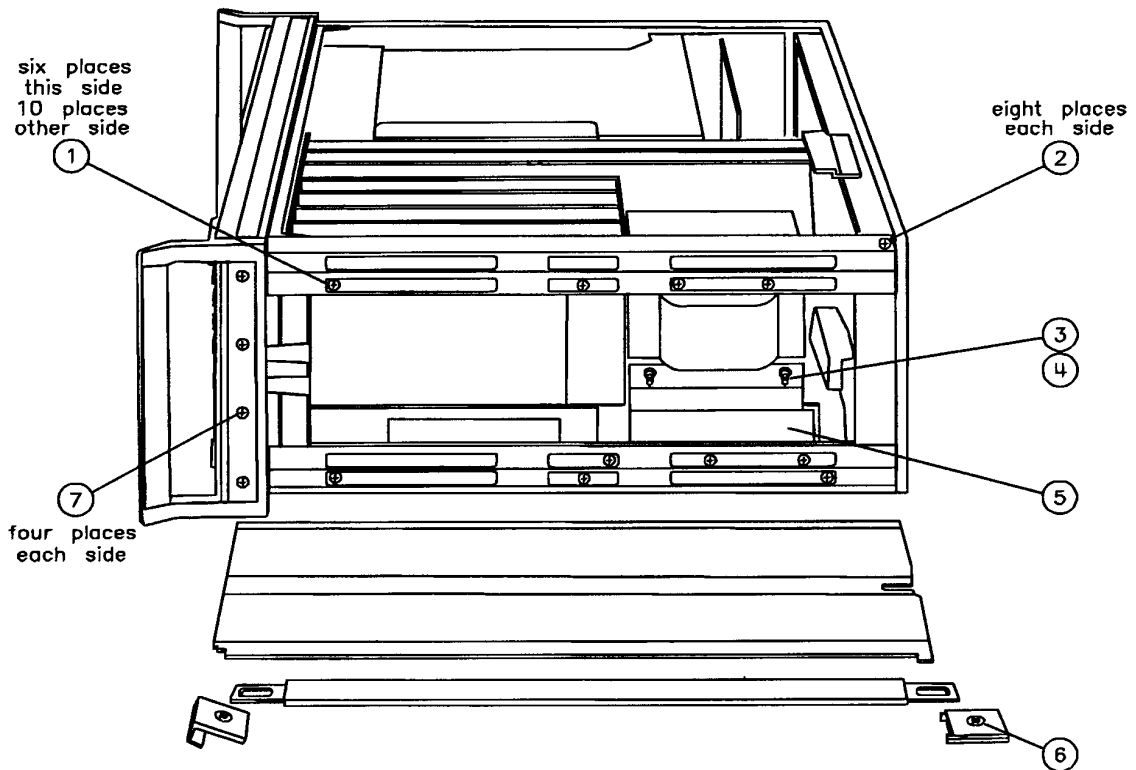
Reference Designation	Agilent Part Number	Qty	Description
1	08757-00045	1	TRANSFORMER MOUNTING FRAME
2	0400-0009	1	GROMMET-RND .125-IN-ID .25-IN-GRV-OD
4	08757-00032	1	REAR SUPPORT
5	0400-0002	1	GROMMET-RND .188-IN-ID .312-IN-GRV-OD
W12	8120-6876	1	VGA CONNECTOR AND CABLE
A3	08757-60157	1	CPU ASSEMBLY
A4	08757-60004	1	ADC ASSEMBLY
A5	08757-60005	1	MODULATOR DRIVE ASSEMBLY STANDARD
	08757-60111	1	MODULATOR DRIVE ASSEMBLY OPTION 002
A6	08757-60006	1	HP-IB ASSEMBLY
A7,A8,A9,A10	08757-60146	4	LOG AMPLIFIER (A9 HP 8757D OPT 001 ONLY)
A14	08757-60147	1	DISPLAY INTERFACE BOARD (GSP)
6	08757-00072	1	CHASSIS DISPLAY INTERFACE MOUNT (SHEET METAL)
T1	9100-4766	1	POWER TRANSFORMER
W7	08757-60071	1	A14 POWER CABLE
W8	08757-60076	1	CABLE AY-34C 28AWG

**Figure 6-6. Bottom View**



Reference Designation	Agilent Part Number	Qty	Description
1	7120-4293	1	WARNING LABEL
2	08757-20084	1	SHIELD
3	0515-0375	2	SCREW SMM3.0 16 CWPNTX
4	0515-0372	5	SCREW SMM3.0 8 CWPNTX
5	0515-0380	1	SCREW SMM4.0 10 CWPNTX
6	1400-0017	1	CLAMP-CABLE .25-DIA .5-WD NYL
7	0515-0380	1	SCREW SMM4.0 10 CWPNTX
8	3050-0893	1	WASHER-FL MTLT 4.0 MM 4.4-MM-ID
9	0515-0374	2	SCREW SMM3.0 10 CWPNTX
10	3050-0893	2	WASHER-FL MTLT 4.0 MM 4.4-MM-ID
11	0515-0380	2	SCREW SMM4.0 10 CWPNTX
13	0515-1079	2	SCREW SMM3.0 8 ETPNPD
14	8160-0649	1	RFI CONTACT
15	08757-00041	1	RFI BASE PLATE
16	0515-0885	2	SCREW-MACH M4 X 0.7 8MM-LG PAN-HD
17	0515-2086	2	SCREW-SMM4.0 7 PCFLT
18	0515-1382	8	SCREW SMM3.5 6 PCFLT
A11	08757-60066	1	MOTHERBOARD
A12	08757-60102	1	POWER SUPPLY BOARD

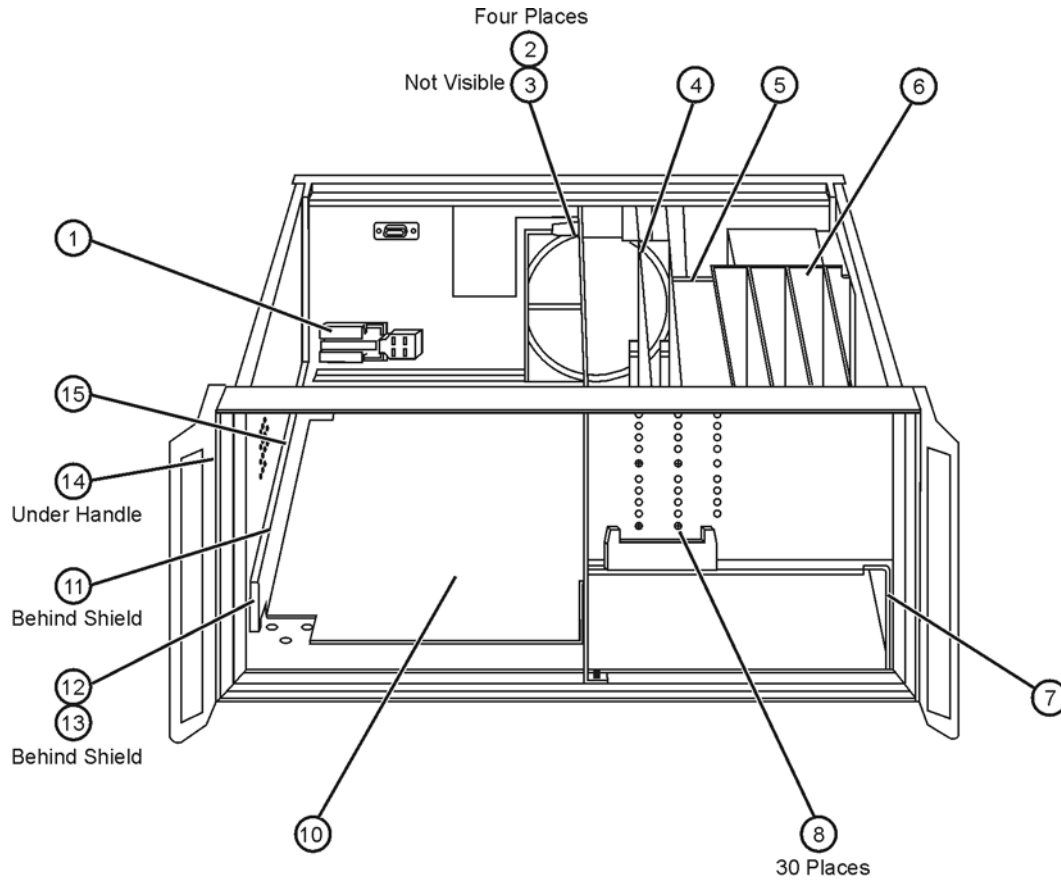
**Figure 6-7. Side View**



Reference Designation	Agilent Part Number	Qty	Description
1	70515-0885	16	SCREW-MACH M3 X 0.5
2	0515-1131	16	SCREW-MACH M5 X 0.8 25MM-LG
3	0515-1145	2	SCREW-MACH M4 X 0.7 80MM-LG PAN-HD
4	3050-0152	4	SCREW-SKT-HD-CAP M6 X 1.0 40MM-LG
5	09757-00045	1	TRANSFORMER MOUNTING FRAME
6	0515-1132	2	SCREW-MACH M5 X 0.8 10MM-LG
7	0515-1368	1	SCREW-MACH M4 X 0.7 10MM-LG

**NOTE** The handle is located on the display side of the instrument.

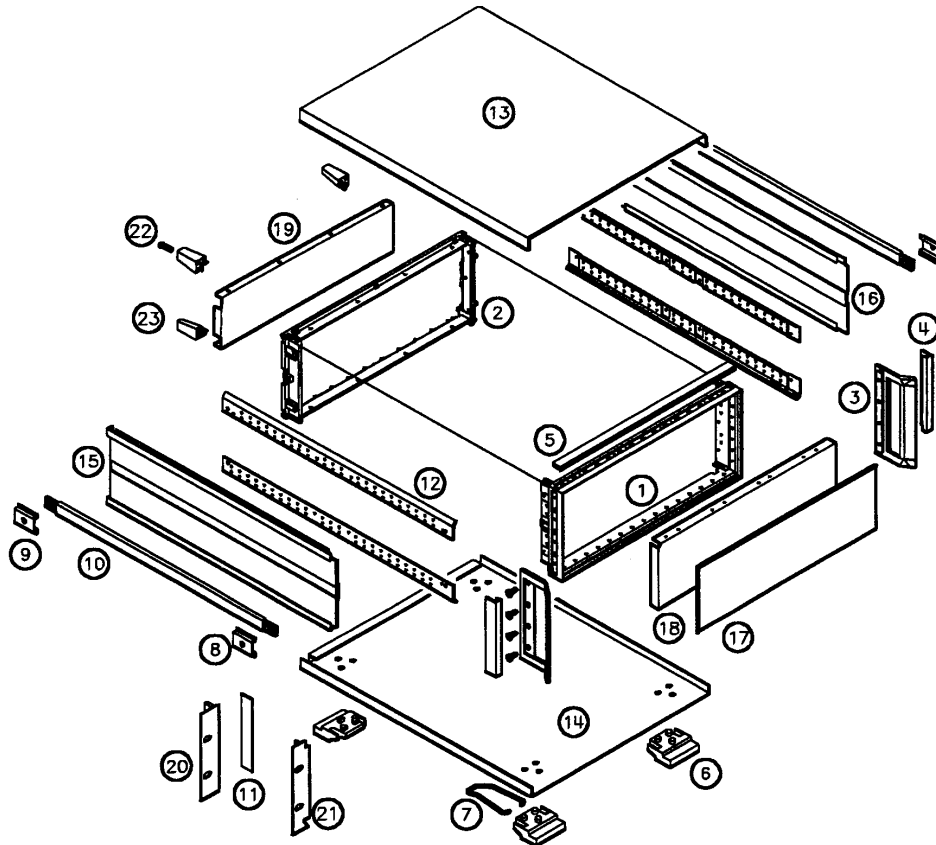
**Figure 6-8 Cage Assembly and LCD Shield**



sa65c

Reference Designation	Agilent Part Number	Qty	Description
1	08757-40009	1	ACTUATOR EXTENDER
2	0515-1079	4	SCREW SMM3.0 8 ETPNPD
3	08757-20071	1	POWER SUPPLY MOUNTING BAR
4	08757-00006	1	DIVIDER
5	08757-00012	1	SEPARATOR
6	08757-00028	1	LOGGER ENCLOSURE
7	08757-00037	1	RIGHT SUPPORT
8	0515-0372	30	SCREW SMM3.0 8 CWPNTX
10	08757-00072	1	CHASIS GSP MOUNT (SHEET METAL)
11	08757-20030	1	ACTUATOR ROD
12	08757-40008	1	SWITCH GUIDE
13	1460-1573	1	EXTENSION SPRING
14	0515-1367	3	SCREW-MACH M4
15	1400-0510	1	CLIP

**Figure 6-9. Frame Exploded View**



Reference Designation	Agilent Part Number	Qty	Description
1	5021-8405	1	FRONT FRAME
2	5021-5806	1	REAR FRAME
3	5062-3990	1	FRONT HANDLE KIT
4	5021-8497	2	FRONT HANDLE TRIM (P/O ITEM 3)
5	5041-8802	1	TOP TRIM STRIP
6	5041-8801	4	BOTTOM FOOT
7	1460-1345	2	TILT STAND
8	5041-8819	1	STRAP HANDLE END COVER (FR)
9	5041-8820	1	STRAP HANDLE END COVER (FM)
10	5062-3703	1	STRAP HANDLE
11	5001-0540	2	SIDE TRIM STRIP
12	5021-5836	4	CORNER STRUT
13	5062-3734	1	TOP COVER (FM)
14	5062-3746	1	BOTTOM COVER (FM)
15	5062-3816	1	PERFORATED SIDE COVER W/ HANDLE RECESS
16	5062-3841	1	PERFORATED SIDE COVER
17	08757-80084	1	FRONT DRESS PANEL (STND) See next page for options
18	08757-00062	1	FRONT SUBPANEL
19	08757-00035	1	REAR PANEL
20	5062-3978	1	P/O MOUNT W/O HANDLE KIT (OPT 908)
21	5062-4072	1	P/O RACK MOUNT WITH HANDLE KIT (OPT 913)
22	5041-8801	4	CORNER FOOT
23	0515-1402	4	SMM 3.5 8PNPTY

**Table 6-2. Replaceable Parts List (1 of 2)**

<b>Agilent Part Number</b>	<b>Qty</b>	<b>Description</b>
<b>Agilent 8757D Option 001</b>		
08757-80085	1	FRONT DRESS PANEL LABEL
08757-60034	1	P/O DETECTOR INTERFACE ASSY
0535-0031	2	NUT M-HXSEM M3.0
08757-80087	1	LOG AMPLIFIER
<b>Agilent 8757D Option 002</b>		
08757-80086	1	FRONT DRESS PANEL LABEL
08757-60111	1	MOD/CAL BOARD ASSEMBLY
00438-60026	1	ADAPTER NF-3.5m WITH CABLE
2190-0104	1	WSHR-LK .439 ID
2950-0132	2	NUT-HEX 7/16-28
<b>Agilent 8757D Option 012</b>		
08757-80083	1	FRONT DRESS PANEL LABEL
08757-60111	1	MOD/CAL ASSEMBLY
08757-60034	1	P/O DETECTOR INTERFACE ASSY
0535-0031	2	NUT M-HXSEM M3.0
08757-60146	1	LOG AMPLIFIER
00438-60026	1	ADAPTER NF-3.5m WITH CABLE
2190-0104	1	WSHR-LK .439 ID
2950-0132	2	NUT-HEX 7/16-28
<b>Agilent 8757D Option 908</b>		
5062-3978	1	RACK MOUNT WITHOUT HANDLES
<b>Agilent 8757D Option 913</b>		
5062-4072	1	RACK MOUNT KIT WITH HANDLES
<b>Agilent 8757D Option 910</b>		
08757-90107	1	8757D O/S MANUAL SET
<b>Update Retrofit/Service Kit</b>		
86383A		HP 8757E TO HP 8757D UPGRADE KIT
08757-60143		HP 8757C TO HP 8757D UPGRADE KIT
86383C Opt 001		HP 8757D OPTION 001 RETROFIT KIT
86383C Opt 002		HP 8757D OPTION 002 RETROFIT KIT
86383C Opt 001/002		HP 8757D OPTION 001/002 RETROFIT KIT
08757-60048		8757D SERVICE KIT

**Table 6-2. Replaceable Parts List (2 of 2)**

<b>Agilent Part Number</b>	<b>Qty</b>	<b>Description</b>
<b>Documentation</b>		
08757-90107		HP 8757D O/S MANUAL SET
08757-90109		HP 8757D OPERATING MANUAL
08757-90110		HP 8757D SERVICE MANUAL
08510-90064		MICROWAVE CONNECTOR CARE
<b>Miscellaneous</b>		
HP 10833A		HP-IB CABLE
6010-1140		COBBLESTONE GRAY TOUCH-UP PAINT
<b>ESD Supplies</b>		
9300-0797		CONDUCTIVE TABLE MAT WITH 15FT GROUND WIRE
9300-0980		WRIST STRAP TO TABLE MAT GROUNDING CORD
9300-1367		GROUNDING WRIST STRAP
9300-1126		ESD HEAL STRAP (REUSABLE TO 12 MONTHS)
<b>Fuse</b>		
2110-0083		FUSE (INCH) 2.5A 250V NTD FE UL
2110-0043		FUSE (INCH) 1.5A 250V NTD FE UL

**Table 6-3. Reference Designations and Abbreviations (1 of 2)**

<p>A.....Assembly                  AT.....Attenuator, Isolator,                  Limiter, Termination                  B.....Fan, Motor                  C.....Capacitor                  CP.....Coupler                  CR.....Diode, Diode Thyristor,                  Step Recovery Diode (SCR), Varactor                  DC.....Directional Coupler                  DS.....Annunciator, Lamp, Light                  Emitting Diode (LED), Signaling Device                  (Audible or Visible)                  E.....Miscellaneous Electrical Part                  F.....Fuse</p> <p style="text-align: center;"><b>A</b></p> <p>A.....Across Flats, Acrylic,                  Air (Dry Method), Ampere                  ADJ.....Adjustment                  AL.....Aluminum                  ALC.....Alcohol, Automatic Level Control                  AMP.....Amperage                  AMPL.....Amplifier                  ANDZ.....Anodized                  ANLG.....Analog                  ASTBL.....Astable                  ATTEN.....Attenuation, Attenuator                  AWG.....American Wire Gauge</p> <p style="text-align: center;"><b>B</b></p> <p>BCKT.....Bracket                  BD.....Board, Bundle                  BE.....Baume, Beryllium                  BFR.....Before, Buffer                  BLK.....Black, Blank, Block                  BNC.....Type of Connector                  BSC.....Basic                  BVR.....Reverse, Breakdown Voltage</p> <p style="text-align: center;"><b>C</b></p> <p>C.....Capacitance, Capacitor,                  Center Tapped, Centistoke,                  CeramicCermet, Circular Mill Foot,                  Closed Cup, Cold, Compression                  CBL.....Cable                  CER.....Ceramic                  CHAM.....Chamfer                  CHAN.....Channe                  COAX.....Coaxial                  COM.....Commercial, Common                  CONN.....Connect, Connection, Connector                  CONT.....Contact, Continuous,                  Control, Controller                  CONV.....Cadmium Plate,                  Candle Power, Centipoise,                  Conductive Plastic, Cone Print</p>	<p style="text-align: center;"><b>REFERENCE DESIGNATIONS</b></p> <p>FL.....Filter                  H.....Hardware                  J.....Electrical                  Connector (Stationary Portion), Jack                  K.....Relay                  L.....Coil, Inductor                  M.....Meter                  MP.....Miscellaneous                  Mechanical Part                  P.....Electrical Connector                  (Movable Portion), Plug                  Q.....Silicon Controlled Rectifier                  (SCR), Transistor, Triode Thyristor                  R.....Resistor</p> <p style="text-align: center;"><b>ABBREVIATIONS</b></p> <p>CRP.....Crepe, Crimp                  CTR.....Center                  CURRNT.....Current</p> <p style="text-align: center;"><b>D</b></p> <p>D.....Deep, Depletion, Depth,                  Diameter, Direct Current                  D/A.....Digital-to-Analog                  DB.....Decibel, Double Break                  DAP.....Diallyl Phthalate                  DC.....Direct Current, Double Contact                  DBL.....Double                  DEG.....Degree                  DIA.....Diameter                  DIFF.....Differential                  DIP.....Dual In-Line Package                  DO.....Package Type Designation                  DRVR.....Driver</p> <p style="text-align: center;"><b>E</b></p> <p>E.....Enamel (Insulation,                  Enhancement, Extension)                  E-MODE.....Enhancement Mode                  EPROM.....Eraseable                  Programmable Read Only Memory                  EXCL.....Excluding, Exclusive                  EXT.....Extended, Extension,                  External, Extinguish</p> <p style="text-align: center;"><b>F</b></p> <p>F.....Fahrenheit, Farad, Female,                  Film, (Resistor), Fixed, Flange, Flint,                  Flourine, Frequency                  FD THRU.....Feed Through                  FEM.....Female                  FF.....Flange, Female Connection, Flip Flop                  FLEX.....Flexible                  FLG.....Flange                  FLTR.....Filter, Floater                  FT.....Feet</p>	<p>RT.....Thermistor                  S.....Switch                  T.....Transformer                  TB.....Terminal Board                  TP.....Test Point                  U.....Integrated Circuit, Microcircuit                  V.....Electron Tube                  VR.....Breakdown Diode                  (Zener), Voltage Regulator                  W.....Cable, Transmission Path, Wire                  X.....Socket                  Y.....Crystal Unit                  (Piezoelectric, Quartz)                  Z.....Tuned Cavity, Tuned Circuit</p> <p>FM.....Flange, Male Connection;                  Foam, Frequency Modulation Product                  (Transition Frequency);Feet, Foot                  FXD.....Fixed</p> <p style="text-align: center;"><b>G</b></p> <p>GEN.....General, Generator                  GHZ.....Gigahertz                  GP.....General Purpose Group                  GL.....Glass                  GRN.....Green                  GRV.....Grooved</p> <p style="text-align: center;"><b>H</b></p> <p>H.....Henry, Hermaphrodite, High                  Hole Diameter, Hot, Hub Inside Diameter,                  Hydrogen                  HD.....Hand, Hard, Head, Heavy Duty                  HEX.....Hexadecimal, Hexagon, Hexagonal                  HGT.....Height</p> <p style="text-align: center;"><b>I</b></p> <p>IC.....Collector Current, Integrated Circuit                  ID.....Identification, Inside Diameter                  IF.....Intermediate Frequency                  IMPD.....Impedance                  IN.....Inch, Indium                  INP.....Input                  INS.....Insert, Inside, Insulation, Insulator                  INT.....Integral, Intensity, Internal                  INTL.....Internal, International                  INV.....Invert, Inverter</p> <p style="text-align: center;"><b>J</b></p> <p>JFET.....Effect Transistor</p> <p style="text-align: center;"><b>K</b></p> <p>K.....Kelvin, Key, Kilo, Potassium                  KB.....Knob</p>
---	--	--



**Table 6-3. Reference Designations and Abbreviations (2 of 2)**

<b>L</b>		
LED.....	Light Emitting Diode	
LG.....	Length, Long	
LIN.....	Linear, Linear Taper, Linearity	
LK.....	Link, Lock	
LKG.....	Leakage, Locking	
LKWR.....	Lockwasher	
<b>M</b>		
M.....	Male, Maximum, Mega, Mil, Milli, Mode, Momentary, Mounting Hole Centers, Mounting Hole Diameter	
MA.....	Milliampere	
MACH.....	Machined	
MAX.....	Maximum	
MCD.....	Millacandela	
MICPROC.....	Microprocessor	
MIN.....	Miniature, Minimum, Minor, Minute	
MLD.....	Mold, Molded	
MM.....	Magnetized Material, (Restricted Articles Code) Millimeter	
MO.....	Metal Oxide Milliounce, Molybdenum	
MOD.....	Model, Modified, Modular, Modulated, Modulator	
MOM.....	Momentary, Motherboard	
MTG.....	Mounting	
MTR.....	Meter	
MULTIPLXR.....	Multiplexer	
MUW.....	Musice Wire	
MW.....	Milliwatt	
<b>N</b>		
N-CHAN.....	N-Channel Metal Oxide Semiconductor	
NB.....	Niobium	
NCH.....	Notched	
NEG.....	Negative	
NH.....	Nanohenry	
NM.....	Nanometer, Nonmetallic	
NO.....	Normally Open, Number	
NPN.....	Negative Positive Negative (Transistor)	
NS.....	Nanosecond, Non-Shorting, Nose	
NYL.....	Nylon (Polyamide)	
<b>O</b>		
OCTL.....	Octal	
OD.....	Olive Drab, Outside Diameter	
OP.....	Operational	
OPT.....	Optical, Option, Optional	
OXD.....	Oxide	
<b>P</b>		
PAN-HD.....	Pan Head	
PC.....	Picocoulomb, Piece, Printed Circuit	
P.C.....	Printed Circuit	
PCB.....	Printed Circuit Board	
PD.....	Pad, Palladium, Pitch Diameter, Power Dissipation	
PF.....	Picofarad; Pipe, Female Connection; Power Factor	
PKG.....	Package	
PL.....	Phase Lock, Plain, Plate, Plug	
PL-MTG.....	Plate Mounting	
PLSTC.....	Plastic	
PN.....	Part Number	
PNP.....	Positive Negative Positive (Transistor)	
POLYC.....	Polycarbonate	
POLYE.....	Polyester	
POS.....	Position, Positive	
POZI.....	Pozidrive Recess	
PRCN.....	Precision	
PRL.....	Parallel	
PRIM.....	Primary	
PRP.....	Purple, Purpose	
P/S.....	Power Supply	
PT.....	Part, Pint, Platinum, Point, Pulse Time	
PVC.....	Polyvinyl Chloride	
PW.....	Power Wirewound, Pulse Width	
<b>Q</b>		
QUAD.....	Set of Four	
<b>R</b>		
RBN.....	Ribbon	
RCVR.....	Receiver	
RECT.....	Rectangle, Rectangular, Rectifier	
RES.....	Research, Resistance, Resistor, Resolution	
RET.....	Retaining	
RF.....	Radio Frequency	
RFI.....	Radio Frequency Inerference	
RFLTR.....	Regulator	
RKR.....	Rocker	
RND.....	Round	
RPG.....	Rotary Pulse Generator	
RR.....	Rear	
RVT.....	Rivet, Riveted	
<b>S</b>		
SCR.....	Screw, Scrub, Silicon Controlled Rectifier	
SEC.....	Secondary	
SER.....	Serial, Series	
SGL.....	Single	
SHFT.....	Shaft	
SHLDR.....	Shoulder	
SI.....	Silicon, Square Inch	
SIG.....	Signal, Significant	
SIP.....	Single In-Line Package	
SKT.....	Skirt, Socket	
SLDR.....	Solder	
SM.....	Samarium, Seam, Small, Square Meter, Sub Modular Subminiature	
SMB.....	Subminiature, B Type (Snap-On Connector)	
SNP.....	Snap	
SPCL.....	Special	
SQ.....	Square	
SST.....	Stainless Steel	
STDF.....	Standoff	
SZ.....	Size	
<b>T</b>		
T.....	Tab Width, Taper, Teeth, Temperature, Tera, Tesla Thermoplastic (Insulation) Thickness, Time, Timed, Tooth, Turns Ratio, Typical	
TA.....	Ambient Temperature, Tantalum	
TC.....	Thermoplastic	
TFE.....	Polytetrafluoro-ethylene, Teflon	
THD.....	Thread, Threaded	
THK.....	Thick	
TO.....	Package Type	
TPL.....	Triple	
TRIG.....	Trigger, Triggerable, Triggering, Trigonometry	
TRMR.....	Trimmer	
TRN.....	Turn, Turns	
TTL.....	Tan Translucent, Transistor, Transistor Logic	
<b>U</b>		
UCD.....	Microcandela	
UNCT.....	Undercut	
UF.....	Microfarad	
<b>V</b>		
V.....	Vanadium, Variable, Violet, Volt, Voltage	
VA.....	Volt Ampere	
VDC.....	Volts, Direct Current	
VIC.....	Video	
<b>W</b>		
W.....	Watt, Wattage, White	
WB.....	Wide Band, Wide, Width, Wire	
WD.....	Width, Wood	
<b>X</b>		
XSTR.....	Transistor	
<b>Y</b>		
YIG.....	Yttrium-iron-garnet	
YTM.....	YIG Tuned Multiplier	
<b>Z</b>		
ZN-P.....	Zener	
ZNR.....	Zener	

**Table 6-4. Manufacturer's Code  
(This table has not been updated since 1992)**

00039	NEC ELECTRONICS INC	MTN VIEW, CA	94043
00046	UNITRODE CORP	LEXINGTON, MA	02173
01074	MEGGITT- ELECTRONICS COMPONENTS LTD	SWINDON, WILTSHI	
01380	AMP INC	HARRISBURG, PA	17111
01417	NEL FREQUENCY CONTROLS INC	BURLINGTON, WI	53105
01607	ALLEN-BRADLEY CO INC	EL PASO, TX	79935
01698	TEXAS INSTRUMENTS INC	DALLAS, TX	75265
01924	ITW FASTEX	DES PLAINES, IL	60016
02010	AVX CORP	GREAT NECK, NY	11021
02037	MOTOROLA INC	ROSELLE, IL	60195
02121	LYN-TRON INC	BURBANK, CA	91505
02180	PRECISION MONOLITHICS INC	SANTA CLARA, CA	95054
02414	BURNNDY CORP	NORWALK, CT	06856
02483	CTS CORP	ELKHART, IN	46514
02499	IRC INC	BOONE, NC	28607
02688	MICROSEMI CORP	SCOTTSDALE, AZ	85252
02883	SILICONIX INC	SANTA CLARA, CA	95054
02910	SIGNETICS CORP	SUNNYVALE, CA	94086
02946	DUPONT E I DE NEMOURS & CO	WILMINGTON, DE	19801
03038	INTL RECTIFIER CORP	LOS ANGELES, CA	90069
03171	SOLITRON DEVICES INC	PALM BEACH, FL	33404
03273	GOWANDA ELECTRONICS CORP	GOWANDA, NY	14070
03285	ANALOG DEVICES INC	NORWOOD, MA	02062
03316	SPECIALTY CONNECTOR CO	FRANKLIN, IN	46131
03394	METHODE ELECTRONICS INC	CHICAGO, IL	60656
03406	NATIONAL SEMICONDUCTOR CORP	SANTA CLARA, CA	95052
03418	MOLEX INC	LISLE, IL	60532
03744	BOURNS NETWORKS INC	RIVERSIDE, CA	92507
03799	HARRIS CORP	MELBOURNE, FL	32901
03811	INTEL CORP	SANTA CLARA, CA	95054
03981	PENN ENGINEERING & MFG CORP	DOYLESTOWN, PA	18901
04055	OVERLAND PRODUCTS CO	PHOENIX, AZ	68025
04200	SPRAGUE ELECTRIC CO	LEXINGTON, MA	02173
04504	GENERAL INSTRUMENT CORP	CLIFTON, NJ	07012
04559	ELASTIC STOP NUT DIVOF HARVARD	UNION, NJ	07083
04568	BECKMAN INDUSTRIAL CORP	FULLERTON, CA	92635
04703	LITTLEFUSE INC	DES PLAINES, IL	60016
04726	3M CO	ST PAUL, MN	55144
04990	GRAYHILL INC	LA GRANGE, IL	60525
05176	AMERICAN SHIZUKI CORP	CANOGA PARK, CA	91304
05313	SEASTROM MFG CO	GLENDALE, CA	91201
05436	BURR-BROWN CORP	TUCSON, AZ	85706
05447	BERGQUIST CO	MINNEAPOLIS, MN	55420
05466	EMHART CORP	FARMINGTON, CT	06032
05518	AUGAT INC	MANSFIELD, MA	02048
05524	DALE ELECTRONICS INC	COLUMBUS, NE	68601
05879	AMPHENOL CORPORATION	DANBURY, CT	06810
06118	ROEDERSTEIN/RESISTA GMBH	LANDSHUT	8300
06121	SIEMENS AG	MUNICH	8000
06337	PHILIPS ELECTRONICS N V	EINDHOVEN	
06347	HITACHI LTD	CHIYODA-KU-TO	101
06691	HOUSE OF METRICS LTD	SPRING VALLEY, NY	10977
08779	MITSUBISHI ELECTRONICS AMERICA	SUNNYVALE, CA	94086
08781	CATALYST RESEARCH CORP	OWINGS MILLS, MD	21117
09538	TUSONIX	TUCSON, AZ	85740
09694	ELECTRONIC ESSENTIALS	WOODSIDE, NY	
09939	MURATA ERIE NORTH AMERICA INC	SMYRNA, GA	30080
10421	EPSON AMERICA INC	TORRANCE, CA	90509
10456	PLASTEC PRODUCTS INC	FORT COLLINS, CO	
10572	XICOR, INC	MILPITAS, CA	
10858	LINEAR TECHNOLOGY CORP	MILPITAS, CA	
11170	PHOENIX TERMINAL BLOCKS	BLOMBERG	
11212	INDUCTOR SUPPLY, INC.	HUNTINGTON BCH, CA	
12186	DALLAS SEMICONDUCTOR CORP	DALLAS, TX	75244

## Chapter 7. Instrument History

---

### INSTRUMENT HISTORY

The original 8757D network analyzer used a cathode-ray tube (CRT) for its display. Agilent Technologies has subsequently replaced the CRT display with a liquid crystal display (LCD). This manual has been updated to include the new LCD related information. Because of this change there may be references to either CRT or LCD that apply to both display designs unless otherwise noted. Refer to the Manual Backdating chapter for CRT information.



# Chapter 8. Troubleshooting

---

## INTRODUCTION

This Chapter provides instructions for troubleshooting and repairing the HP 8757D Scalar Network Analyzer. The information provided includes self-tests and diagnostic tests, circuit descriptions, troubleshooting procedures, schematics, and component locations diagrams.

Self-tests are tests performed by the analyzer at power-on or preset that check the internal circuitry of the instrument to verify normal operation. Diagnostic tests are tests initiated by the operator to verify specific functional areas of the instrument.

Overall circuit description and troubleshooting information is provided to isolate problems to the assembly level. Tabbed subChapters of this Chapter then document each PC board assembly in numerical order from A1 through A16. Most of the assembly sub-chapters provide a circuit description, diagnostic tests, troubleshooting information, pin-outs, component location diagrams, and schematic diagrams. Assemblies utilizing Surface Mount Technology (SMT) must be replaced at the assembly level. Component level troubleshooting and repair in the field is not practical.

## SCHEMATIC DIAGRAM NOTES

Figure 8-1, "Schematic Diagram Notes", provides a key to the symbols and abbreviations used in the schematic diagrams.

## RECOMMENDED TEST EQUIPMENT

Test equipment required for repairing and troubleshooting the analyzer is listed in table 4-1. If the equipment listed is not available, equipment that meets the minimum specifications shown can be substituted.

## WIRING LIST AND MNEMONICS

Table 8-26, "Motherboard Wiring List", alphabetically lists and describes all analyzer signal mnemonics. The source of each signal is identified, and the point-to-point distribution is referenced to and from the PC board sockets and rear panel and motherboard connectors. This table is located in the A11/A13 sub-chapter.

The internal interconnect cables are listed in table 6-3, "Replaceable Parts".

## TROUBLESHOOTING

### WARNING

These servicing instruction are for use by qualified personnel only. To avoid electrical shock, do not perform any servicing unless you are qualified to do so.

## **WARNING**

**After repair, make sure all safety features are intact and functioning, and all protective grounds are solidly connected.**

Troubleshooting information in this manual is generally divided into two levels. The first level isolates the problem to an assembly. This level includes self-tests and associated error codes, overall instrument troubleshooting information, and the overall troubleshooting block diagram. Some operator-initiated diagnostic tests are also available at this level.

The second troubleshooting level isolates the problem to the defective component. This information is provided in the tabbed subChapters for each assembly. This component-level troubleshooting information includes circuit descriptions, operator-initiated diagnostic tests, and schematic diagrams for the individual assemblies.

## **CAUTION**

**The A3 CPU, A4 ADC, A7–A10 log amplifier, and A5 mod/cal (option 002 only) assemblies CANNOT be interchanged or replaced without recalibrating the analyzer. Boards can be temporarily interchanged for troubleshooting purposes, but each board must be returned to its original position. Recalibration of the analyzer requires the use of an HP 11613A/B calibrator and an HP 9000 Series 200/300 computer.**



















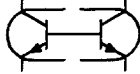




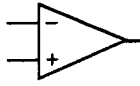








## **WARNING**

The opening of covers or removal of parts is likely to expose dangerous voltages. Disconnect the product from all voltage sources while it is being opened.

## **WARNING**

The power cord is connected to internal capacitors that may remain live for 5 seconds after disconnecting the plug from its power supply.

## BASIC COMPONENT SYMBOLOGY

<p>R,L,C Resistance is in ohms, inductance is in microhenries, capacitance is in microfarads, unless otherwise noted.</p> <p>P/O Part of.</p> <p>* Indicates a factory selected component.</p> <p>○ Panel Control.</p> <p>◐ Screwdriver adjustment.</p> <p>▭ Encloses front panel designation.</p> <p>▭▭ Encloses rear panel designation.</p> <p>— Circuit assembly borderline.</p> <p>- - - Other assembly borderline.</p> <p>→ Heavy line with arrows indicates path and direction of main signal.</p> <p>→ Indicates path and direction of main feedback.</p> <p>⊥ Earth ground Signal.</p> <p>▽ Assembly ground. May be accompanied by a number or letter to specify a particular ground.</p> <p>⏏ Chassis ground.</p> <p><math>\frac{n}{/}</math> Represents n number of transmission paths.</p> <p>● Test Point: Terminal provided for test probe.</p>	<p> Pin Edge Connector output of PC board.</p> <p> Indicates wire or cable color code. Color code same as resistor color code. First number indicates base color, second and third numbers indicate colored stripes.</p> <p> Indicates shielding conductor for cables.</p> <p> Indicates a plug-in connection.</p> <p> Indicates a soldered or mechanical connection.</p> <p> Connection symbol indicating a male connection.</p> <p> Connection symbol indicating a female connection.</p> <p> Resistor.</p> <p> Variable resistor.</p> <p> General purpose diode.</p> <p> Step recovery diode.</p> <p> Schottky diode.</p> <p> Breakdown Diode: Zener</p> <p> Light-Emitting Diode.</p> <p> SCR (Silicon Controlled Rectifier).</p> <p> Thermistor</p>	<p> FET: Field Effect Transistor (N-channel).</p> <p> FET: Field Effect Transistor-Guarded gate (N-channel).</p> <p> Dual Transistor.</p> <p> Transistor NPN</p> <p> Transistor PNP</p> <p> Electrolytic Capacitor.</p> <p> Toroid: Magnetic core inductor.</p> <p> Operational Amplifier.</p> <p> Fuse</p> <p> Toggle Switch.</p> <p> Pushbutton switch.</p> <p> Thermal Switch.</p> <p> Summing Point.</p> <p> Oscillator; RPG (Rotary Pulse Generator).</p> <p> Fan, Motor.</p> <p> Toroidal Transformer.</p>
--	--	---

*Figure 8-1. Schematic Diagram Notes (1 of 2)*

LINE LABEL ABBREVIATIONS					
CK, C	Clock Input	MSB	Most Significant Bit	T	Trigger Input (Monostable)
D	Data or Delay Input (Flip-Flop)	Q	Output	WR	Write
EN	Enable	$\overline{Q}$	Not Q Complement of Q	+1	Count Up
F	3-State Enable Input	R	Reset or Clear Input	-1	Count Down
G	Gating Input	RD	Read	3-ST	3-State (placed by function)
LSB	Least Significant Bit	S	Set Input		




FUNCTION LABEL ABBREVIATIONS					
$\Sigma$	Adder	$\diamond$	Open Collector	LED	Light-Emitting Diode
	Amplifier/Buffer		Monostable Multivibrator	MUX	Multiplexer
	Schmitt Trigger	BCD	Binary Coded Decimal	RAM	Random-Access Memory
&	AND	CTR	Counter	REG	Register
>1	OR	DAC	Digital-to-Analog Converter	ROM	Read Only Memory
=1	Exclusive OR	FF	Flip-Flop	RPG	Rotary Pulse Generator
X $\rightarrow$ Y	Encoder, Decoder	I/O	Input/Output		

Figure 8-1. Schematic Diagram Notes (2 of 2)



## SELF-TESTS

Each time the analyzer is powered-on or preset it performs a self-test routine. This routine consists of a series of fifteen self-tests numbered in descending numerical order from 15 to 1, and four calibration constant checksum tests (one for each input). Self-test 1 is an instrument verify routine that consists of additional self-checks that can also be accessed from the service menu. If any part of the self-test routine fails, an error code or error message is generated.

In addition to the self-tests performed automatically by the analyzer, several diagnostic tests are available that can be forced by the operator if the front panel is not functioning. These tests, error codes, and error messages are described in more detail in "Error Codes".

For troubleshooting purposes, the entire self-test sequence can be bypassed by closing switch A3S1D and pressing **PRESET**. The microprocessor will skip the self-tests and begin executing the routines associated with normal operation, if possible.

## Error Codes

The self-test routine performed by the analyzer at power-on or preset checks major functional areas of the instrument to verify normal operation. If any portion of the self-test routine fails, an error code between 15 and 1 is generated to indicate the nature of the failure and to guide troubleshooting. A summary of self-tests and error codes is provided in Table 8-1. Error codes are displayed in one or more of the following three places:

1. **A3 CPU LEDs.** Four red LEDs on the A3 CPU assembly (labeled MSB) indicate an error code between 15 and 0 (0 indicates pass). This is referred to as the *main* error code. The LEDs have a binary weight of 8-4-2-1 from left to right. This is the most reliable of the three error condition indicators. There are an additional four LEDs on this board that provide more specific error analysis. These are labeled "LSB" and are referred to as the *sub* error code.
2. **Front Panel HP-IB STATUS Lights.** The four HP-IB STATUS lights on the front panel also indicate a main error code between 15 and 0. These lights are labeled R-L-T-S, from left to right, and have a binary weight of 8-4-2-1 respectively. This error code indication is identical to the A3 error code, although it functions only if the A1/A2 front panel assemblies and the instrument bus are working properly.
3. **Display.** The front panel display may indicate error or warning messages. Error messages occur in conjunction with some error codes to provide additional failure information. Warning messages indicate other conditions that may affect accuracy, prevent normal operation, or require service attention. Warning messages are not associated with error codes. Error messages and warning messages are available only if the A15 display and its associated circuitry is working.

**Table 8-1. Self Test and Main Error Code Summary**

<b>MSB LED Reading 8-4-2-1</b>	<b>MAIN Error Code</b>	<b>Test Description/Explanation</b>	<b>Additional Information</b>
1-1-1-1	15	Microprocessor kernel	A3 CPU
1-1-1-0	14	ROM checksum	A3 CPU
1-1-0-1*	13	RAM checksum	A3 CPU
1-1-0-0	12	Power supply failure	A12 Power Supply
1-0-1-1	11	Instrument bus	A3 CPU
1-0-1-0	10	Display interface—GSP	A14 Display interface
1-0-0-1	9	Display interface —DRAM	A14 Display interface
1-0-0-0	8	Display interface —DRAM load	A14 Display interface
0-1-1-1	7	Display interface —DRAM cell	A14 Display interface
0-1-1-0	6	Display interface —VRAM	A14 Display interface
0-1-0-1*	5	Display interface —VRAM cell	A14 Display interface
0-1-0-0	4	Display interface —Control	A14 Display interface
0-0-1-1	3	Display interface —R,G,B	A14 Display interface
0-0-1-0	2	Interrupt	A3 CPU
0-0-0-1	1	Instrument Verify and other tests	Instrument Verify (in this subsection)
0-0-0-0	0	Pretest pass	N/A

\*Performed only at power-up and manual instrument verify.

## Self-Test Sequence

The self-tests are performed in the following sequence:

Self-test	Failure generates error code
15	15
14	14
13	13
12	12
11	11
10	10
9	9
8	8
7	7
6	6
5	5
4	4
3	3
2	2
1	1
0	Self-test passes

Performed at power-up.

Performed at power-up

Calibration constant checksum for input A.  
Calibration constant checksum for input B.  
Calibration constant checksum for input C (Option 001 only).  
Calibration constant checksum for input R.

Self-test 1 includes these instrument verify routines:

- RAM.
- Instrument bus.
- Display bus.
- Timer.
- ADC measurement.
- ADC bit check.
- DAC bit check.
- Sweep compare.
- Detector control.
- Unexpected keypress.
- EEROM write enable.
- Battery failure.
- Configuration error.

Self-test 1 is described in “Instrument Verify”.

Calibration checksum warning messages are described in “Calibration Constants”.

For error codes other than 1, see Table 8–1. This table references the sub-chapters that provide troubleshooting information pertinent to each error code. Many error codes cause the CPU to enter a cycle that repeats the self-test continuously. This produces a repeatable pattern for troubleshooting purposes.

## Instrument Verify

This routine is a collection of nine major self-checks. These tests are performed at power-on and during an instrument preset. They can also be run at any time by pressing the **INSTR VERIFY** softkey in the service menu. If an instrument verify test fails (error code 1), the routine does not automatically enter into any cyclical tests as the other self-test routines do. Instead you have a choice of repeating the instrument verify test, entering the service menu, or entering the normal measurement routine (ignoring the failure).

The tests performed as part of the instrument verify routine are listed in Table 8–2, along with references for more information. The first three tests are similar to self-tests 13, 11, and 10.

*Table 8–2. Instrument Verify Table*

Test	More Information
RAM	A3 Troubleshooting, Error Code 13
Instrument bus	A6 Troubleshooting, Instrument Bus Test
Display bus	A14 Troubleshooting, Error Code 10
Timer	A3 Troubleshooting, Timer Test
ADC measurement	A4 ADC Diagnostic Tests
ADC bit check	A4 ADC Diagnostic Tests
DAC bit check	A4 ADC Diagnostic Tests
Sweep compare	A4 ADC Diagnostic Tests
Detector control	A4 ADC Diagnostic Tests

## Forced Diagnostic Tests

To call up most diagnostic tests the A1 front panel and A2 front panel interface assemblies must work correctly. However, some diagnostic tests can be called during self-test without a functioning front panel. To access these tests, close the indicated status switch sections of A3S1 on the A3 CPU assembly. Then press **PRESET**, or cycle the power momentarily to start the self-test. During self-test, the microprocessor reads the status lines and jumps immediately to the required test. The tests are listed in Table 8–3, along with the switch sections to be closed. Closed, in this case, means setting the switch toward the left side of the instrument when viewed from the front. A closed switch is indicated by a “0”; an open switch by a “1”. Do not confuse the EEPROM write protect switch with one of the status switches. The write protect switch is A3S1–E; the status switches consist of A3S1–A through A3S1–D. The write protect switch is listed solely to prevent confusion while viewing switch positions; it should always be open “1”.

Table 8–3. Forced Diagnostic Tests

To perform this test	Close "0" the indicated status switches, then press [PRESET]					More Information
	A3S1–A	A3S1–B	A3S1–C	A3S1–D	A3S1–E	
Normal operation	1	1	1	1	1	N/A
A3 CPU read/write cycle	0	1	1	1	1	A3 CPU
Instrument bus cycle	1	0	1	1	1	A6 HP–IB
Display bus test cycle	0	0	1	1	1	A14 display interface
Front panel cycle	1	1	0	1	1	A1/A2 front panel
Read key cycle	0	1	0	1	1	A1/A2 front panel
CPU interrupt test	1	0	0	1	1	A3 CPU
Skip ROM checksum	0	0	0	1	1	N/A
Skip all self tests	1	1	1	0	1	N/A
A14 DRAM cycle	0	1	1	0	1	A14 Display interface
A14 VRAM bank 0 cycle	1	0	1	0	1	A14 Display interface
A14 VRAM bank 1 cycle	0	0	1	0	1	A14 Display interface
A14 VRAM bank 2 cycle	1	1	0	0	1	A14 Display interface
A14 VRAM bank 3 cycle	0	1	0	0	1	A14 Display interface
A14 VRAM device indicator	1	0	0	0	1	A14 Display interface
A14 repeating gray scale	0	0	0	0	1	A14 Display interface

## Calibration Constants and Checksum Errors

The HP 8757D has over one thousand calibration points stored in two EEPROMs on the A3 CPU assembly. This data is matched to each individual log amplifier assembly, and is used to correct for differences in gain, log shaping, and offsets in each board. This data is only valid if all the boards remain in their designated input locations (they are not swapped with each other). In addition, the calibration data is only valid with a specific A4 ADC assembly. Therefore the A3 CPU, A4 ADC, and A7–A10 log amplifier assemblies *cannot* be interchanged or replaced without recalibrating the analyzer. If necessary, boards can be temporarily interchanged for troubleshooting purposes, but each board must be returned to its original position. Recalibration of the analyzer requires the use of a specific calibrator (HP 11613A/B) and an HP 9000 Series 200/300 computer.

After the self–tests have been completed the CPU performs a checksum test on each of the four portions of EEPROM that contain the calibration data for each input. If the checksum does not correspond with the stored data, the warning message `Default calibration table used on X` is displayed on the CRT, where X equals all the input channels (A, B, C, or R) that failed the checksum test. If one or more of the checksums passes while one or more fails, the CPU duplicates the calibration data of a passing input for those that fail. This results in improper calibration, and degrades the dynamic accuracy of the affected inputs by about  $\pm 1$  dB, but the analyzer can be used with these limitations until a recalibration can be performed.

If the checksums fail for all the inputs, the CPU generates a default table to be used by all inputs. This degrades the dynamic accuracy by about  $\pm 2$  dB.

Calibrator constants for the option 002 calibration are NOT checked during self tests but are checked each time the calibrator is used.

## Other Error Messages

The error messages listed below, used mostly for firmware development, should normally never appear. If they do, it indicates that the microprocessor is “confused” and has attempted an illegal command. Some of the possible conditions that cause this are:

- Anomalies in the firmware.
- Failure of one or more ROMs.
- Failure of one or more RAMs.
- Intermittent shorts or opens on the A3 CPU address or data lines.
- Failures in the I/O timing.

The possible error messages are:

- Bus ERROR.
- Adrs Error.
- Code Err.
- ZERO DIV.
- CHK INSTR.
- TRAPV INSTR.
- PRIV VIOLATION.
- TRACE.
- 1010 EMULATOR.
- 1111 EMULATOR.
- Processing Error.

## Power Calibration Error Messages

The HP 8757D Option 002 power calibration process senses when improper connections are made. The following error messages describe the type of connection error detected. These are *not* tested during self test but rather at the beginning of or during the power cal routine.

**Check Connections Calibration Error #1** The HP 8757D has detected power applied to the detector from a source other than the calibrator.

**Check Connections Calibration Error #2** The HP 8757D has not measured power at the detector when the calibrator is programmed to generate power. apparently, the detector is not connected to the calibrator output, or the incorrect input was selected by the operator for calibration.

**Check Connections Calibration Error #3** The HP 8757D has found that the detector was disconnected from the calibrator output before the calibration process was complete.

**Calibrator Error #1** The HP 8757D firmware has detected a problem with the calibration data stored in the instrument's CPU EEPROM. Refer to the Service manual.

**Calibrator Error #2 (or greater)** The HP 8757D firmware has detected a problem with the calibrator hardware. Refer to the Service manual.

## Notes on Self-tests

1. Most self-tests performed at preset or power-on will enter a continuous loop if the test fails. This allows the technician to observe and track down shorted or open address, data, and control lines, even if the front panel or CRT is not operable. For instance, if the instrument bus test fails (error code 11), which may render the front panel and CRT useless, the A3 CPU enters the instrument bus cycle test automatically. This writes a known pattern to the address and data lines to make troubleshooting a simple, straight-forward procedure.
2. Most of the cyclical self-tests produce a TTL trigger pulse at the CONTROL 1 output connector on the rear panel. The falling edge of this pulse occurs at the beginning of each repetition of a cycle, to trigger an oscilloscope. This allows for one simple setup using the external trigger input of the oscilloscope, without the difficulty normally associated with reliably triggering on multiple digital pulses. The external trigger of the oscilloscope should be DC coupled and set for a negative-going transition at about +3 V. Most waveforms illustrated in this service Chapter were obtained using this pulse as a trigger.
3. Many self-tests write a *walking 1* pattern to one or more devices via the data bus. These tests verify that each of the sixteen data lines can be controlled independently and that data can be written and then read back. The TTL trigger pulse previously described is sent at the beginning of each cycle.

The walking 1 pattern begins with the CPU writing all ones to a memory location and then reading it back. It then writes all zeros and reads it back. Then a logical 1 is written to D0 (the least significant bit) while the other data lines are 0 (0000 0000 0000 0001). This information is then read back. Then the logical 1 is shifted to the next more significant bit (0000 0000 0000 0010) and read again. This cycle is continued until the most significant bit is a logical 1 (1000 0000 0000 0000). Since each step consists of a write and a read, this will produce an 18 step double-pulse walking 1 pattern. Any discrepancy between data written and data read back is reported as an error. A sample of part of this double-pulse walking 1 pattern during the instrument bus test is shown in Figure 8-30.

4. In tests involving the data lines, any failure of a data bit is indicated by a "1" in the appropriate location on the display. Bit positions are always shown with the most significant bit (MSB) on the left and the least significant bit (LSB) on the right.

5. The waveforms in this manual show the test patterns of a normally working instrument. When a failure occurs, more than one line may be affected. In addition, the timing of individual parts of a cycle may be very different from that shown in the waveforms. How the test is entered can also make a difference. For example, the display bus cycle test takes about 93  $\mu$ S if entered from the front panel softkeys. As a forced diagnostic test, it takes about 91 mS. If the test is automatically entered upon a bus failure, it takes about 155  $\mu$ S. If the display ribbon cable happens to be disconnected and the test is automatically entered at preset, the duration of the test is 325  $\mu$ S. Remember that upon failure, timing relationships can vary considerably.
6. Waveforms shown in this manual were actually taken from a working instrument. Most were taken using the CONTROL 1 trigger pulse on the rear panel (see item 2). Where many waveforms are shown on one graph, each trace shows a digital signal. The amplitude is 5 or 6 volts per division unless noted otherwise. This is sufficient to show the logical condition of each part of the trace. Where analog traces are shown, the amplitude per division is noted and the zero volt DC level is indicated.

## OPERATOR–INITIATED DIAGNOSTIC TESTS

Diagnostic tests are tests initiated by the operator to verify specific functional areas of the instrument. These tests are available in five levels of menus subsidiary to the service menu. The service menu is obtained by pressing **SYSTEM** **MORE** **SERVICE**. The diagnostic tests are listed by menu level in Table 8–3. For information on performing these tests, see “Diagnostic Tests” in the individual assembly subChapters.

### Hexadecimal Tests

The following tests are accessed using the **HEX TESTS** softkey in the service menu. These hexadecimal read/write and rotate tests are general in nature, and can be used to test many different parts of the instrument. Using hex read/write, the CPU is instructed to access a user–specified memory or I/O address and read or write data from or to that address, or write a rotating 1 data pattern.

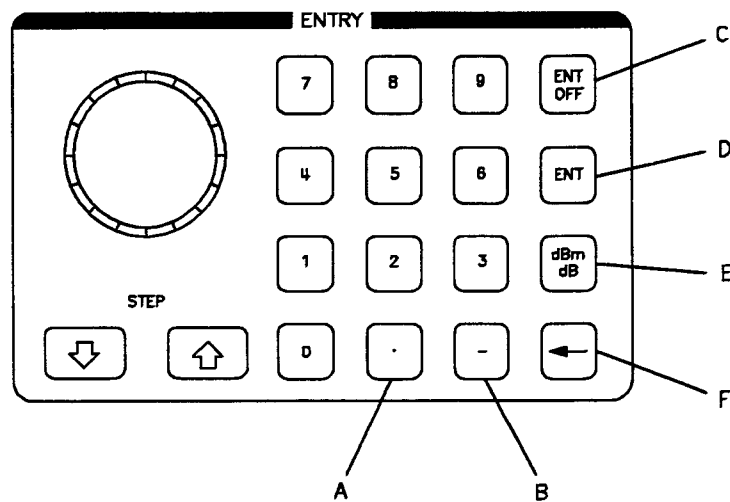
These tests use the hexadecimal (hex) numbering system. Hex digits from 0 to 9 and A to F represent decimal numbers from 0 to 15, as shown in Table 8–4. Each hex digit represents four binary digits or bits. An address is specified by six hex digits, while a data word is specified by four hex digits.

During hex read/write, certain ENTRY keys are redefined to represent hex digits A through F, as shown in Figure 8–2.



*Table 8–4. Hexadecimal Equivalents*

Hexadecimal	Binary	Decimal
0	0000	0
1	0001	1
2	0010	2
3	0011	3
4	0100	4
5	0101	5
6	0110	6
7	0111	7
8	1000	8
9	1001	9
A	1010	10
B	1011	11
C	1100	12
D	1101	13
E	1110	14
F	1111	15



*Figure 8–2. Hexadecimal Entry Keys*

**ADDRESS**

This key is used to enter the hexadecimal address of a memory or I/O device in the instrument. Press **ADDRESS**, then enter six hexadecimal characters for the address location, using the redefined ENTRY keys. Include any leading or trailing zeros. Only even addresses are allowed; any odd address entered is automatically decremented by 1.

After entering the address, press **READ**, **WRITE**, or **ROTATE** for the following functions.

## **READ**

This key tells the CPU to read and display data from the specified address. Press **READ**, and the message RD DATA is displayed, together with four hex digits of data read from the addressed location. The read function is repeated, so if the data changes, new data is displayed. FFFF is usually shown when data is read from an illegal (write-only) address. Be sure that the read mode is applicable at the address in question.

Press **ADDRESS** to enter a new address, or use the STEP keys to automatically read the next sequential address.

## **WRITE**

This key writes data to the specified hexadecimal address. Press **WRITE**, then enter four hex digits of data to be written to the addressed location, using the redefined ENTRY keys. Leading or trailing zeros must be entered. The data is written automatically upon entry of the last digit of the four-digit entry. Data is written one time only. To write data again, press the **WRITE** key again.

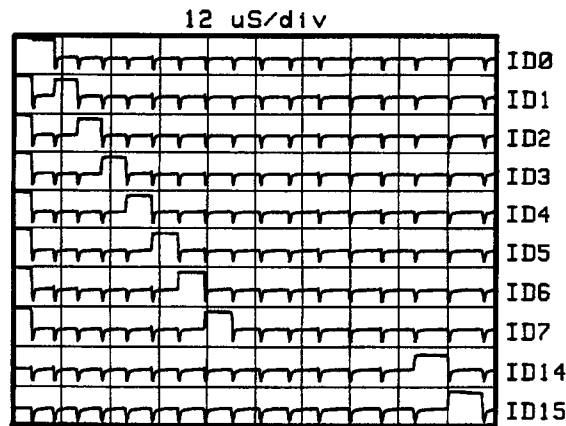
Press **ADDRESS** to enter a new address. Or press **READ**, **WRITE**, or **ROTATE** to read data, write new data, or write the rotating data pattern to the same address.

## ROTATE

This test is particularly helpful to find missing, shorted, or stuck data bits. This test sends a *rotating 1* data pattern to the address selected. The data pattern is a sixteen-bit word, with one bit high and the remaining fifteen low. Each successive bit (D0 through D15) is written high in turn. The test is continuous and repetitive with a trigger pulse available at the CONTROL1 output on the rear panel. A typical hex data rotate waveform for several instrument bus data lines is shown in Figure 8-3.

### CAUTION

Never attempt to perform a hex data rotate on EEPROM (address 0C0000 to 0FFFFE) with the write-protect switch closed. The EEPROMs can accept only a limited number of write cycles. Because this test repeats continuously, it will quickly destroy the memory retention capability of the EEPROMs.



Hex rotate to instrument bus showing part of walking '1' pattern. Note increasing width of each pulse.

Figure 8-3. Hex Data Rotate Waveforms

*Table 8–5. Operator–Initiated Diagnostic Tests (1 of 2)*

The service menu is accessed by pressing **PRESET** **SYSTEM** **MORE** **SERVICE** .

**NOTE:** This table applies to an instruments with a LCD display. See Backdating chapter for CRT related information.

Menu Level Within Service Menu				
1	2	3	4	5
DISPLAY	TEST PATTERN	PRIOR MENU EXIT SERVICE		
	DISPLAY TEST	REPEAT CYCLE <sup>1</sup> PRIOR MENU EXIT SERVICE		
	MORE	BCKGRND RAMP <sup>1</sup> INTNSTY RAMP <sup>1</sup> PRIOR MENU EXIT SERVICE		
HEX TESTS	PRIOR MENU EXIT SERVICE			
	ADDRESS READ WRITE ROTATE PRIOR MENU EXIT SERVICE			
A1/2 FP	READ RPG <sup>1</sup> READ KEY <sup>1</sup>			
	CYCLE LEDS PRESET DISABLE PRIOR MENU EXIT SERVICE	SOFTKEYS 1 SOFTKEYS 2 SOFTKEYS 3 SOFTKEYS 4 SOFTKEYS 5 SOFTKEYS 6 SOFTKEYS 7 SOFTKEYS 8		
A3 CPU	RAM TEST	REPEAT PRIOR MENU EXIT SERVICE		
	TIMER <sup>1</sup> EEPROM TEST	EXECUTE PRIOR MENU EXIT SERVICE		
	READ STATUS <sup>1</sup> INTRPT PRIOR MENU EXIT SERVICE			
A4 ADC	ADC MEAS ADC BIT CHECK DAC BIT CHECK DET CONTROL <sup>1</sup> SWEEP COMPARE			

**Table 8-5. Operator-Initiated Diagnostic Tests (2 of 2)**

The service menu is accessed by pressing **PRESET** **SYSTEM** **MORE** **SERVICE**.

Menu Level Within Service Menu				
1	2	3	4	5
A4 ADC (Cont'd)	MORE	RAMP <sup>1</sup> CHANNEL VOLTS	CHANV LOGGER <sup>1</sup> CHANV DETDAC <sup>1</sup>	DET DAC ENTER DET DAC MAX DET DAC MIN MODE 1 MODE 2 MODE 3 PRIOR MENU EXIT SERVICE
	PRIOR MENU SERVICE MENU	DATA READY <sup>1</sup> READ DATA <sup>1</sup> PRIOR MENU EXIT SERVICE	CHANV OTHER <sup>1</sup>	SWP DAC ENTER SWP DAC MAX SWP DAC MIN PRIOR MENU EXIT SERVICE
			PRIOR MENU EXIT SERVICE	
A6 HPIB INSTBUS	HPIB TESTS	HPIB TALK HPIB LISTEN PRIOR MENU EXIT SERVICE		
	INSTBUS TEST	REPEAT CYCLE PRIOR MENU EXIT SERVICE		
	PRIOR MENU EXIT SERVICE			
INST VERIFY EXIT SERVICE				

1. Indicates a cycling self-test with an oscilloscope trigger pulse available at the CONTROL 1 BNC connector on the rear panel, even though test results displayed on the CRT are not necessarily updated. This feature is very useful for troubleshooting.

## OVERALL INSTRUMENT DESCRIPTION

Refer to Figure 8–4, “HP 8757D Simplified Block Diagram”.

The HP 8757D Scalar Network Analyzer is a microprocessor–based receiver for making scalar (magnitude only) transmission and reflection measurements on microwave devices. Any of three inputs in the standard instrument (A, B, and R) or four inputs in Option 001 (A, B, C, and R) may be chosen to make absolute or ratio measurements on four identical but independent measurement channels. In addition to the HP 8757D receiver, a typical measurement setup includes a swept microwave source, compatible microwave detectors, directional bridges, and couplers.

The analyzer uses either AC or DC detection techniques of scalar network analysis. In AC detection, the microwave source is amplitude modulated on and off at 27.778 kHz with a 50% duty cycle square wave. External detectors peak detect the microwave signal after it has passed through any device under test or directional accessories. In DC detection, an AC/DC detector or bridge modulates the detected signal at 27.778 kHz. This eliminates the need for amplitude modulation of the source. Although the square wave frequency is fixed at 27.778 kHz (regardless of the microwave frequency), its amplitude corresponds to the power level of the microwave signal. Because the amplitude information is carried at 27.778 kHz, the analyzer is AC coupled and tuned to 27.778 kHz to reduce DC offset errors and noise.

### Overview

The A, B, C (Option 001), and R detector inputs are logarithmically shaped and rectified by identical log amplifiers A7, A8, A9, and A10. The outputs are DC voltages representing a microwave power level for each input. These analog signals are converted to digital data by the A4 ADC (analog–to–digital converter) and read by the A3 CPU (central processing unit). The A3 CPU processes the data and sends it to the A14 display interface which then formats it to be viewed on the A15 display. The A3 CPU also interfaces with the A1/A2 front panel, and can communicate with other instruments through the A6 HP–IB over two HP–IB ports. The A5 modulator driver provides a 27.778 kHz drive at the rear panel to amplitude modulate the microwave source or an external modulator, if required. The A12 power supply provides four supply voltages for the analyzer, as well as two independent supplies for the A14 display interface and A15 display.

### A7/A8/A9/A10 Log Amplifiers

The A7/A8/A9/A10 log amplifiers buffer, filter, log, and rectify the front panel input signals. The output from each log amplifier is a DC voltage proportional to the 27.778 kHz modulation envelope being detected at each of the inputs.

External microwave accessories (detectors or bridges) detect the 27.778 kHz amplitude modulated signal received. The amplitude of the 27.778 kHz detector output represents the microwave power level of the input. The A, B, C, and R inputs are connected to the A7, A8, A9, and A10 log amplifiers respectively. The buffer at the input of each log amplifier assembly isolates the signal and eliminates common–mode noise. A bandpass filter with a 27.778 kHz center frequency further reduces noise and filters the square wave into a sine wave. The logarithmic amplifier circuit produces an output waveform proportional to the logarithm of its input signal. This output waveform represents the input in dB. The precision rectifier then peak detects the log shaped 27.778 kHz sine wave, producing a DC voltage proportional to the 27.778 kHz detector output in dB.

## A4 Analog-to-Digital Converter (ADC)

The A4 ADC assembly converts the DC voltages from the A7/A8/A9/A10 log amplifiers into digital information to be read by the A3 CPU.

Each output from the A7/A8/A9/A10 log amplifiers goes to a buffer and sample/hold circuit on the A4 ADC assembly. The A4 ADC samples and digitizes the DC voltage representing the microwave power level (the vertical or Y-axis on the display) at 101 to 1601 points during a sweep (the horizontal or X-axis on the display). The sample/hold timing is controlled by the sweep comparator. The sweep comparator has two inputs: the 0 to 10 V dc SWEEP IN ramp from the external source, proportional to frequency, and internal sweep DAC (digital-to-analog converter) voltage, controlled by the A3 CPU.

With the sample/hold switches closed (sample mode), the sample/hold sequence is the following:

1. The A3 CPU sets the sweep DAC to a voltage corresponding to one of the points along the 0 to 10 V dc SWEEP IN ramp. The inputs (a maximum of four) to be digitized are also selected.
2. The sweep ramp from the source rises smoothly until it equals the sweep DAC voltage, firing the sweep comparator and opening the sample/hold switches (hold mode).
3. The ADC converts the analog signals into digital form, and stores them into temporary memory.
4. The sample/hold switches are closed (sample mode).
5. The A3 CPU reads the digitized outputs from the temporary memory.
6. The A3 CPU sets the next DAC voltage, enables the sweep comparator, and the cycle repeats for the rest of the sweep.

The blank/marker detector decodes the various levels on the POS Z BLANK input from the source. The blank/marker detector recognizes four distinct levels for the A3 CPU to read:

- +5 V dc =Blank (retrace and bandswitch points).
- 0 V dc =Display (normal trace, forward sweep).
- -4 V dc =Marker (intensity markers).
- -8 V dc =Active marker (high intensity markers).
- The A3 CPU can halt the forward sweep of the source with the stop sweep driver.
- Also located on this assembly is the detector control circuitry. This allows the A3 CPU to monitor the detector's characteristics and control its operating mode.

## A3 Central Processing Unit (CPU)

The A3 CPU (essentially a small computer) coordinates and controls all major functions in the analyzer. It communicates with other assemblies via the instrument bus. In this way, the A3 CPU reads the digitized inputs from the A4 ADC, processes and formats the data, and sends it to the A14 display interface board. The A3 CPU communicates with the A1/A2 front panel via the instrument bus, and with external instruments or a controller via the A6 HP-IB assembly.

The microprocessor steps through its program, executing program instructions from ROM (read-only memory) via its internal digital bus. The microprocessor also stores and retrieves temporary data in RAM (random access memory). The RAM is protected with a battery supply so that data is not lost when line power is switched off. The instrument bus interface provides buffering for the instrument bus to communicate with other major assemblies. Calibration data is stored in non-volatile EEPROM.

In normal operation, the microprocessor reads digital information from the A4 ADC through the instrument bus to determine the A, B, C, and R input values. In most cases, the microprocessor performs several calculations on the raw data (error correction with calibration constants, normalization, averaging, and two-channel ratioing) using data from RAM. Then the A3 CPU formats the information and sends it to the A14 display interface to be viewed.

The A3 CPU also communicates with the A1/A2 front panel and the A6 HP-IB via the instrument bus.

### **A14 Display Interface (GSP), A15 LCD Display, and A16 Inverter**

The A14 display interface assembly receives digital information from the A3 CPU and generates the signals required to present data on the A15 LCD display.

The digital interface of the A14 board is connected to the A3 CPU via the instrument bus. The display processor on the A14 board drives both the LCD display and an external VGA interface.

The A16 inverter provides high voltage power for the backlight lamp on the A15 LCD display.

### **A1/A2 Front Panel**

The A1 front panel and A2 front panel interface allow the user to select measurement modes and alter measurement parameters with the front panel keys and rotary knob. The instrument's HP-IB status is indicated on the front panel with LEDs.

The A1 front panel and A2 front panel interface provide the interface between the A3 CPU and the user. The keyboard interface and RPG (rotary pulse generator) interface decode the pushbutton keyboard and RPG knob for the A3 CPU to read. The detector bias circuits, part of the A2 front panel interface, provide bias supplies for external detectors through the front panel input connectors.

### **A6 HP-IB**

The A6 HP-IB (Hewlett-Packard Interface Bus) assembly provides two IEEE-488 ports with rear panel connectors, for the analyzer to communicate with other instruments and controllers.



HP–IB interfaces allow the synchronous A3 CPU to interface with the asynchronous IEEE–488 format. Bidirectional HP–IB drivers buffer and drive the two ports. Although the two HP–IB ports are electrically identical, they are *not* interchangeable. The HP INTERFACE BUS port is the general purpose HP–IB port, and is normally connected to an external controller such as a calculator or desktop computer. The controller then remotely controls the analyzer. Other instruments can also be connected to the HP INTERFACE BUS port in a system configuration with the external controller. The 8757 SYSTEM INTERFACE port, however, allows the analyzer itself to control a compatible source, plotter, and printer. External controllers cannot normally use this port.

## A5 Modulator Driver

The A5 modulator driver provides a 27.778 kHz square wave output at the rear panel to amplitude modulate the microwave source or an external modulator when the analyzer is in AC mode.

If the source has accurate internal 27.778 kHz  $\pm 20$  Hz square wave modulation, no connection to the MODULATOR connector of the analyzer is required. If the source does not have internal square wave modulation, the signal from the MODULATOR connector can be used to control the AM or pulse modulation inputs of the source. The A3 CPU controls the square wave modulation on/off function through the instrument bus.

If the HP 8757D includes option 002, the A5 board also contains a precision 50 MHz calibrator capable of providing precisely known 1dB power increments from +20 to –50 dBm.

## A12 Power Supply

The A12 power supply provides two sets of regulated DC supply voltages for the analyzer. One set consists of the +15 V, +5 V, –15 V, and –12.6 V regulated power supplies. The +15 V, +5 V, and –15 V supplies are used to power the analog and digital circuitry in the analyzer. The +15 V and –12.6 V supplies are used to bias external detectors through the front panel input connectors. A separate set of display power supplies provide +65 V and +5 V for the A14 display interface and A15 display.

## OVERALL INSTRUMENT TROUBLESHOOTING

Refer to Figure 8–5, “HP 8757D Overall Troubleshooting Block Diagram”.

This Chapter describes the first level of troubleshooting procedures to diagnose and repair a faulty analyzer. Failures are described by symptom and are listed in the order in which these symptoms should be checked. This is because the microprocessor and front panel must be functioning properly for other problems to be effectively diagnosed.

Most procedures isolate a failure to a single major assembly. Refer to the troubleshooting Chapters for the individual assemblies for additional information.

## Line Power and Power Supplies

Assumptions: None.

### Symptoms:

- The fan does not rotate when line power is turned on.
- The display is blank.
- The front panel LEDs are all off.

(Power supply failures may be responsible for many apparently unrelated symptoms.)

Connect the analyzer to a known good line power source and turn on the line power switch. (Be sure that the correct fuse is installed.) Listen for the fan rotating. If the fan is not rotating, check the voltage selector card and line fuse on the rear panel line module.

The fan is a DC fan operating from the —15 V unregulated supply. If it is not operating check fuse A12F8.

A thermal switch is wired in series with the line power switch to shut down the analyzer if the heat sink on the A12 power supply exceeds 90°C. If the analyzer shuts itself down, turn the line switch off and allow the instrument to cool. Check the fan filter and ensure it is clean. All instrument filters should be cleaned regularly, once a month or more often. A clogged filter will cause overheating and consequent degradation of performance.

Remove the bottom cover and check the A12 power supply. There are two supply voltages for the A14/A15 display and four more for the remaining assemblies. All six supplies are monitored by six green LEDs. These LEDs light when the corresponding supply voltages are within approximately 20% of nominal. If one or more LEDs does not light, check the six fuses on the A12 power supply. Test points are also available near each LED so that each supply voltage can be measured with a DVM. Refer to A12 power supply "Troubleshooting" for details. Failures in any supply other than the +5 V instrument supply should be caught with the self-tests upon power up (error code 12).

## Self-Test and Error Codes

Assumptions: Line power is present, power supplies are verified.

### Symptoms:

- A binary error code is displayed on the A3 CPU LEDs or the front panel HP-IB STATUS LEDs.
- An error message is displayed on the CRT.

Turn on the line power or press **PRESET** to cause the analyzer to go through its preset routine. This brief but thorough self-test routine verifies that key parts of the analyzer are functioning. If any part of the self-test fails, the resulting error condition is indicated in one or more of three places:

1. A3 CPU. Four red LEDs on the A3 CPU (labeled "MSB") indicate an error code between 15 and 0. The LEDs have a binary weight of 8-4-2-1 from left to right. These error code indicators are the most reliable.
2. Front Panel R-L-T-S. The four HP-IB STATUS lights on the front panel also indicate an error code between 15 and 0 (identical to the A3 board). These lights are labeled R-L-T-S, from left to right, and have a binary weight of 8-4-2-1 respectively. This error code indicator functions only if the A1/A2 front panel assembly and the instrument bus are working correctly.

3. Display. The CRT display indicates other error conditions and more detailed error messages. This error indicator functions only if the A14 and A15 display assemblies are working correctly.

Turn on the analyzer or press **PRESET**. If any error code or other message appears on any of the three error code indicators, refer to "Self Tests" and Table 8–1 for further information on where to look for troubleshooting techniques.

## Front Panel

Refer directly to A1 front panel and A2 front panel interface "Diagnostic Tests" and "Troubleshooting" for all front panel problems.

## Display

Refer directly to A14 display interface "Diagnostic Tests" or "Troubleshooting" for all display problems. From this point it should be easy to isolate any problem to either the A14 display interface or the A15 display.

## Data Acquisition and Sweep Comparators

**Assumptions:** Power supplies are good; self-test passes; front panel and display function normally. The analyzer is connected and configured as shown in Figure 8–5, "HP 8757D Overall Troubleshooting Block Diagram", (POS Z BLANK of source connected to POS Z BLANK of HP 8757D, and SWEEP OUT of source connected to SWEEP IN 0–10V of HP 8757D).

**Symptoms:**

- No trace on display.

**NOTE:** This applies when there is no trace whatsoever on the display. This condition is caused when the analyzer is not tracking the SWEEP IN 0–10V or POS Z BLANK from the source. This condition prevents any data from being taken or displayed. If *any* trace appears on the display, regardless of whether it is noisy or whether the amplitude is correct, refer directly to "Analog Accuracy".

Check A4TP17 (SWP) for a 0 V to –10 V sweep ramp (inverted). If it is absent, check the SWEEP OUT signal from the source, and the connections. Lack of a sweep may indicate that the source's STOP SWEEP line is held low. Remove any connection to the STOP SWEEP line from the source. If the source's sweep ramp is present but there is still no sweep ramp at TP17, refer to A4 ADC "Troubleshooting", especially the sweep buffer information.

Check A4TP15 (DAC) for a 0 V to +10 V ramp. Also check A4TP13 (HOLD), A4TP11 (L CNV), and A4TP10 (L CC) for activity. If any or all signals are absent, refer to A4 ADC "Troubleshooting."

## Analog-to-Digital Conversion and Analog Accuracy

**Assumptions:** Power supplies are present and accurate (refer to A12 power supply "Troubleshooting" for nominal voltages and limits). Self test passes; front panel and display function normally; A4TP15 (DAC) shows a 0 V to +10 V ramp; A4TP13 (HOLD), A4TP11 (L CNV), and A4TP10 (L CC) show bursts of activity. The analyzer is connected to an HP 8350B Sweep Oscillator and configured as shown in NO TAG, "HP 8757D Overall Troubleshooting Block Diagram".

Symptoms: There is a *horizontal* trace on the display, but the *vertical* information is one of the following:

- Noisy.
- On the extreme top or bottom graticule, or at +20 dBm or -70 dBm (for a single input measurement).
- Does not reflect the actual detector input power within  $\pm 1.0$  dB.

Set up a known square wave modulated power level to the detector. Determine which of the inputs (A, B, C, or R) is defective. If all the inputs appear defective, perform a system configuration by pressing **CAL** **CONFIG SYSTEM**. Check the detector, source, square wave modulation, and the bias voltages to the front panel detector input connectors.

Remove the bottom cover and check the cables and connections between the front panel input connectors and the A11 motherboard (these cables are P/O W1, W2, W3, and W4). Check the bias connections to the A2 front panel interface (P/O W1-4). Check the bias to the detectors at the front panel jacks.

Check the output voltages from the log amplifiers A7/A8/A9/A10 to the A4 ADC first with a +10 dBm modulated signal applied to the detectors and then at the noise floor (no signal applied). The typical log amplifier output voltage is approximately +6.5 V at +10 dBm and approximately -6.3 V at the noise floor. If these voltages are present, the corresponding log amplifiers are probably functional. If not, press **MEAS** and select the defective input. Then press **CAL** **MORE** **AUTO CAL OFF** **TEMP CAL OFF** and remove the corresponding log amplifier from its connector. The display should indicate approximately -32 dBm. If so, refer to A7/A8/A9/A10 log amplifier "Troubleshooting." If not, refer to A4 ADC "Troubleshooting." Note that if **CONFIG SYSTEM** is pressed while a log amplifier assembly is removed, the displayed data is completely invalid.



**The A7-A10 log amplifier assemblies CANNOT be interchanged or replaced without recalibrating the analyzer. Boards can be temporarily interchanged for troubleshooting purposes, but each board must be returned to its original position. Recalibration is also required if adjustments are altered on the log amplifiers. Recalibration of the analyzer requires the use of an HP 11613A/B calibrator and an HP 9000 Series 200/300 computer.**

## HP-IB

Assumptions: Self test passes; analyzer functions normally in manual operation.

Symptoms:

- The HP interface bus or 8757 system interface does not function correctly.

- The analyzer does not respond to the controller through the HP INTERFACE BUS port.
- The analyzer cannot control the HP 8350B, 8340A/B, 8341A/B, printer, or plotter through the 8757 system interface.

Check the connections between the analyzer and other instruments or the controller. The HP INTERFACE BUS port must be connected to a computer controller (such as the HP 9836A) and cannot be used when the analyzer is acting as controller. The 8757 SYSTEM INTERFACE port must be connected only to a compatible source, printer, or plotter, not to an external controller. Other instruments are not allowed (unless **SYSINTF ON/OFF** in the sweep mode menu is set to **OFF**). Refer to the *Operating Reference* in Chapter 3 of the operating manual for details. There must be no bus connection between the two ports.

Check the addresses of all equipment attached to either port. The analyzer must not be set to the same address as any other device connected to either the HP INTERFACE BUS port or the 8757 SYSTEM INTERFACE port. Refer to the description of the local menu in the *Operating Reference* for more information.

Check the controller software used to command the analyzer. Software errors are often the source of HP-IB problems. If in doubt, run the example programs given in the introductory programming guides included in Chapter 3 of the operating manual. Do not use an HP 9876A printer, if transferring digital data, as this may cause the system to lock up.

Verify the two ports with internal diagnostic tests. Remove all connections from both ports, and attach only a single HP-IB cable between the HP INTERFACE BUS port and the 8757 SYSTEM INTERFACE port. On the analyzer, press **PRESET** **SYSTEM** **MORE** **SERVICE** **A6 HPIB INSTBUS** **HP-IB TESTS** **HP-IB TALK**.

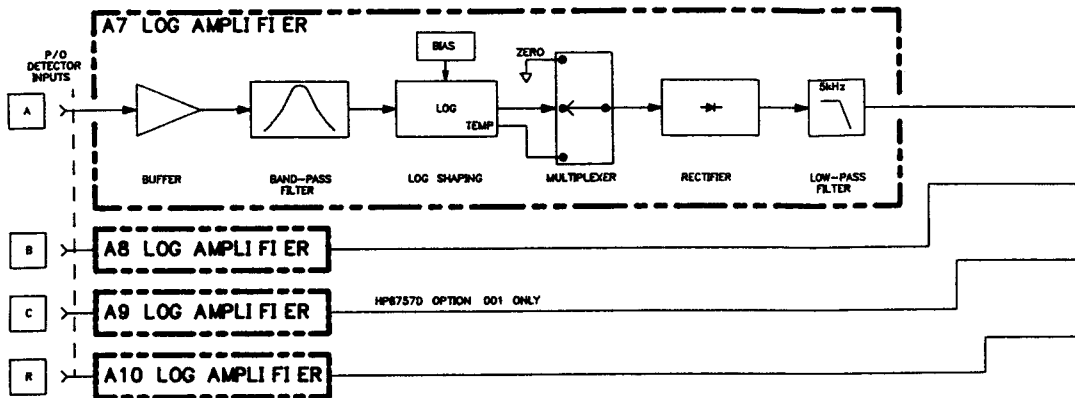
The message **HPIB TALK PASS** indicates that the HP INTERFACE BUS port can send data to the 8757 SYSTEM INTERFACE port. Next press **HP-IB LISTEN**. The message **HPIB LISTEN PASS** indicates that the HP INTERFACE BUS port can accept data from the 8757 SYSTEM INTERFACE port. Any other message indicates a failure. (In both tests, the 8757 SYSTEM INTERFACE acts as the bus controller.) Refer to A6 HP-IB "Troubleshooting" for further information.

## Modulation

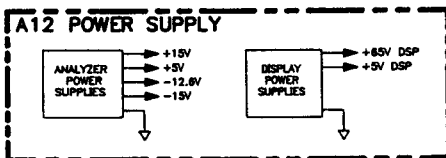
Refer directly to A5 modulator "Troubleshooting" for all modulation drive problems.

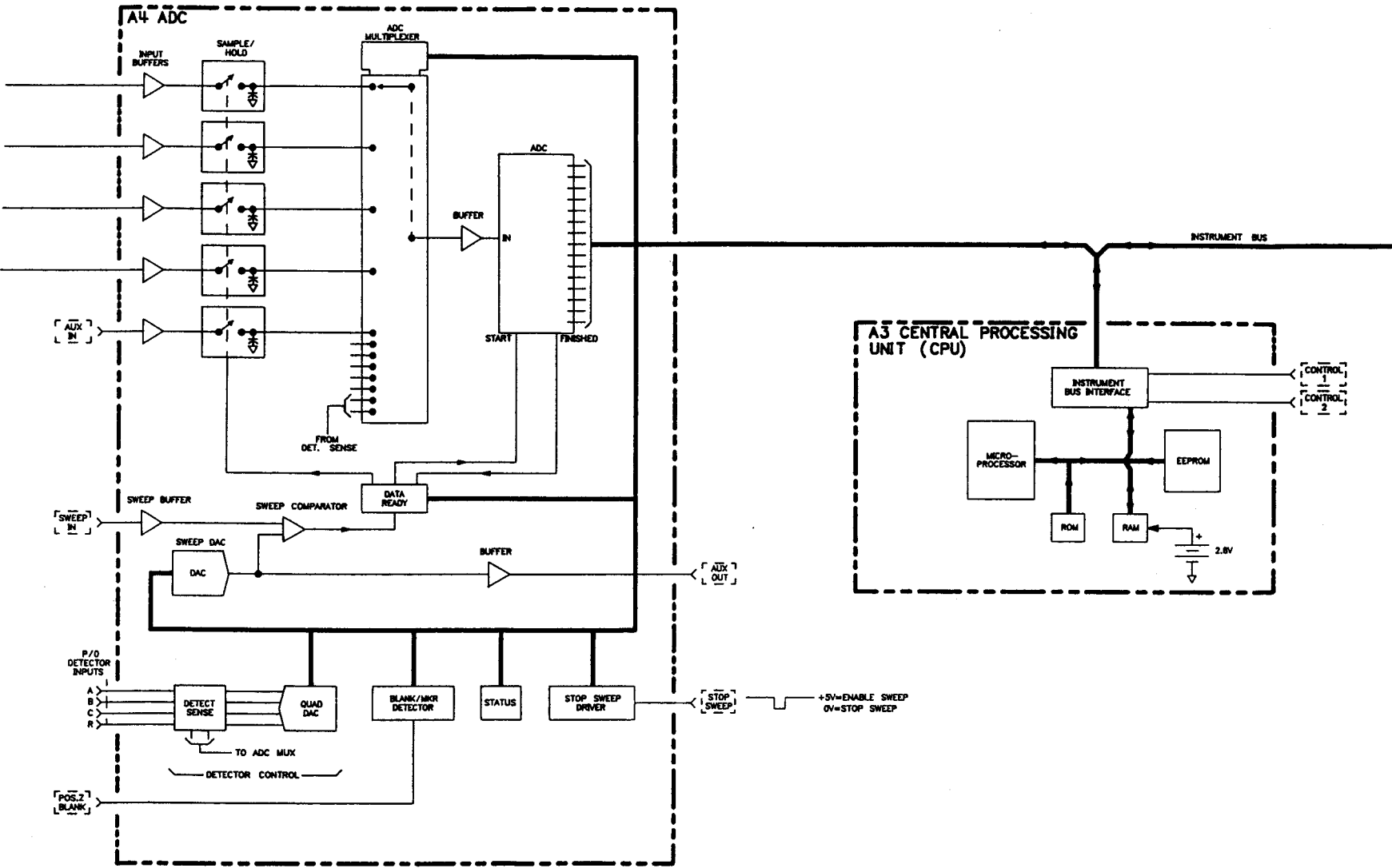


8757 SIMPLIFIED BLOCK DIAGRAM

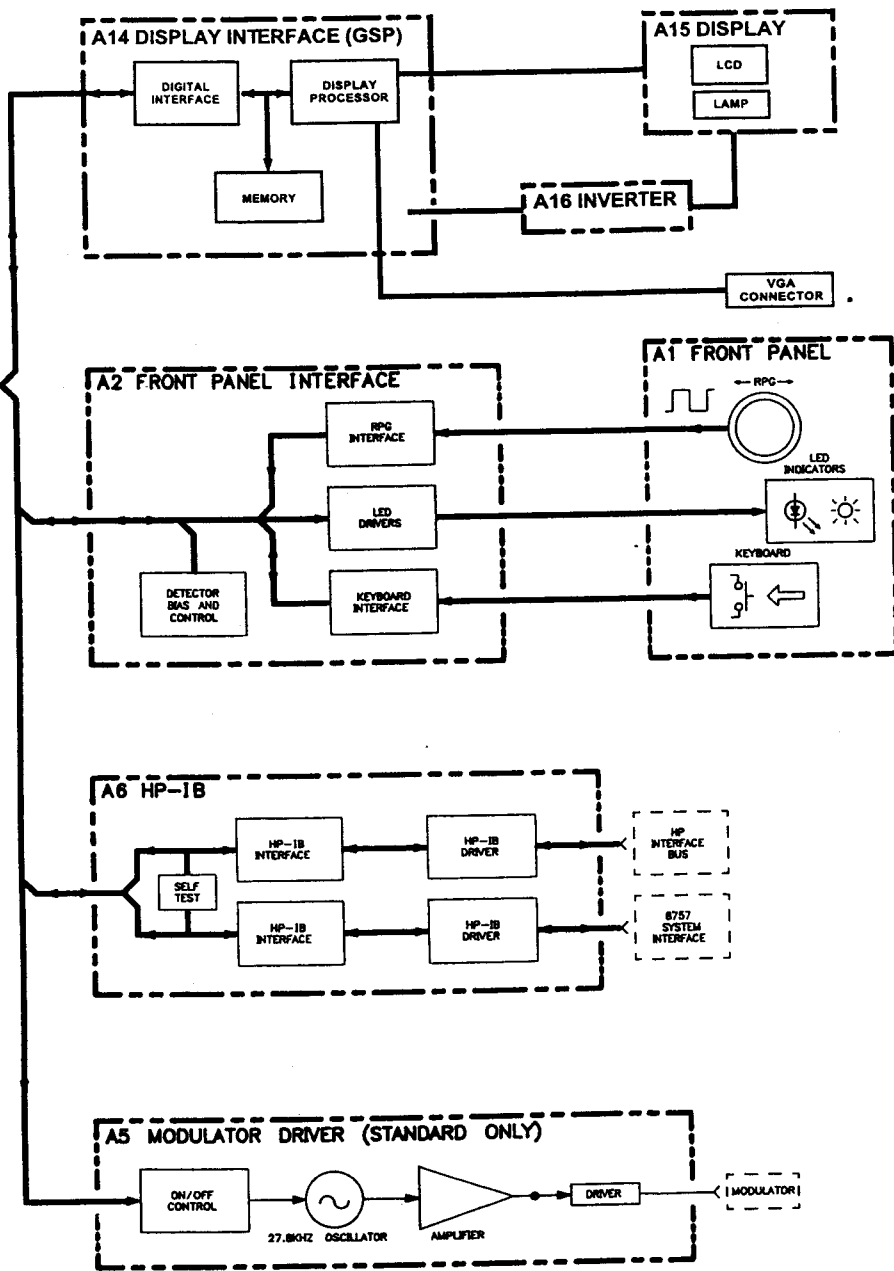


NOTE: ALL LOG AMPS ARE IDENTICAL

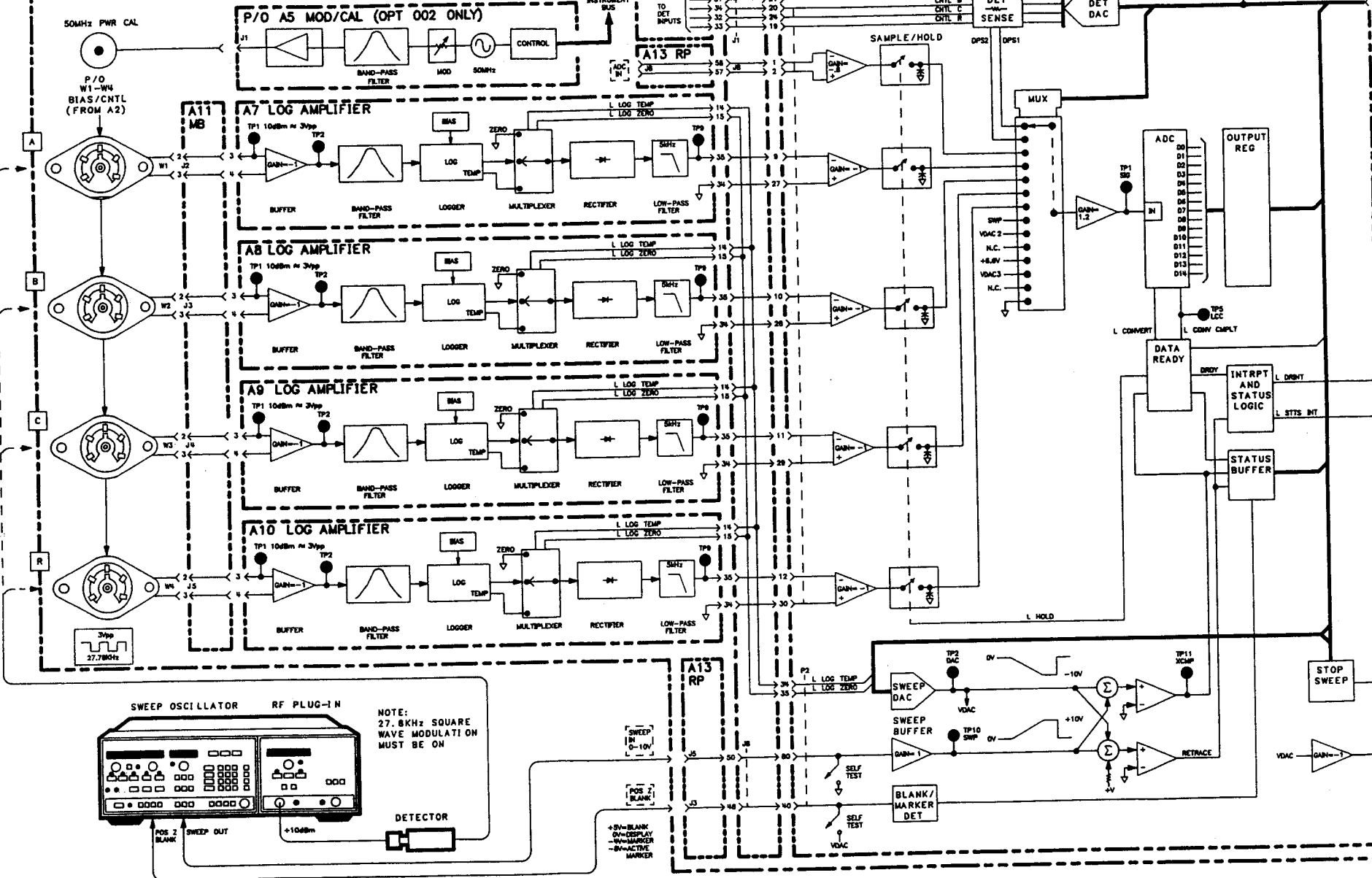




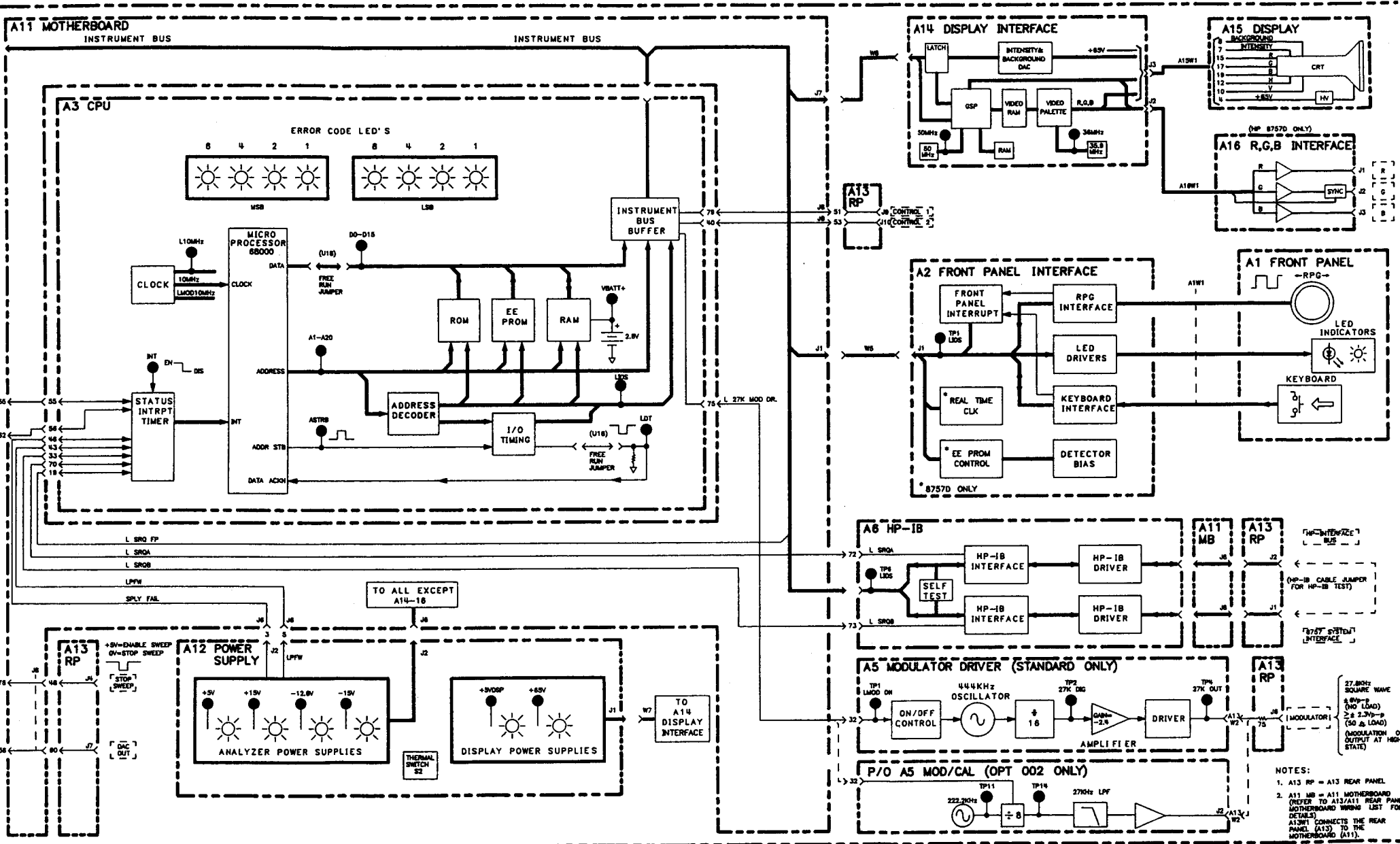




8757D OVERALL TROUBLESHOOTING BLOCK DIAGRAM



NOTE:  
27.8KHz SQUARE  
WAVE MODULATION  
MUST BE ON



- NOTES:
1. A13 RP = A13 REAR PANEL
  2. A11 MB = A11 MOTHERBOARD (REFER TO A13/A11 REAR PANEL MOTHERBOARD WIRING LIST FOR DETAILS)
- A13RP CONNECTS THE REAR PANEL (A13) TO THE MOTHERBOARD (A11).
- 27.8KHz SQUARE WAVE  
 4.9uV-p  
 (NO LOAD)  
 2.3V-p-p  
 (50 Ω LOAD)  
 OSCILLATOR OF  
 OUTPUT AT HIGH  
 STATE

Figure 8-5. 8757 Overall Troubleshooting Block Diagram (Back Dating)

## A1 Front Panel and A2 Front Panel Interface

### CIRCUIT DESCRIPTION

The A1 front panel and A2 front panel interface are documented together. The circuit description is organized functionally and applies to both assemblies.

The A1 front panel and A2 front panel interface provide the interface between the A3 CPU (central processing unit) and the user. In manual operation, the user specifies measurement modes, selects inputs, enters reference or scaling values, and controls other functions with the front panel pushbutton keys and the RPG (rotary pulse generator) knob. The A3 CPU reads the keyboard and RPG through the A2 front panel interface, and takes the appropriate action. The A3 CPU also causes a display of the current HP-IB status using LEDs (light emitting diodes) on the front panel. The A2 board also contains circuitry to read and write to the detector EEPROMs and bias circuitry to power the detectors. Refer to the A1/A2 schematic, Figure 8-8, for the following descriptions.

#### A. ADDRESS DECODER/RESET

The A3 CPU reads from and writes to the A1/A2 front panel through the instrument bus. The address decoder decodes the instrument bus address lines to select the proper circuit to send or receive the information on the data lines. Three-to-eight decoder U5 decodes address lines IA1, IA2, and IA3 to pulse one of six output lines low. Address lines IA4 through IA8, plus L IOS, enable the outputs and control the timing. Inverter U7 buffers and inverts two lines. One address decoder output resets the RPG circuit (rather than controlling the flow of data.) Table 8-1 lists the six address decoder outputs, together with the appropriate addresses to activate them and the functions they perform.

The reset filter buffers the L RESET line from the A3 CPU to the A2 front panel interface. L RESET goes low to reset the keyboard interface column driver and LED drivers. The L RESET line is filtered to prevent front panel noise pulses from resetting other assemblies in the instrument.

#### B. REAL TIME CLOCK

U21 is a real time clock used to provide time/date labeling on plots and on disc files (NOT implemented on some revisions of firmware). U21 contains an internal battery for time keeping functions. The battery life should be about ten years. Control for the clock is derived from address lines IA5 through IA8 and is decoded in PAL U19.

#### C. POWER SUPPLY

An LC filter reduces digital noise on the +5VDIG supply voltage. Local capacitive filtering reduces noise near susceptible components. The +5 V supply for the front panel LEDs is received through A1W1. There are no active components on the A1 front panel assembly.

The short circuit protection will shut down the +15 and –12.6 volt supplies to the front panel detector connectors if more than about 130 or 80 mA, respectively, is drawn from the supplies. Current sensing is performed by sensing the voltage drop across the 1000 mH inductor in each leg of each supply (see “F. Detector Bias/Control”). The resistance of this inductor is typically 15 ohms. When the voltage drop exceeds 1.25 or 2 volts, the corresponding comparator will turn on, pulling L BIAS OFF low. This shuts off both supplies by turning off Q1 and Q3. It also signals the CPU which enables the 3 Hz flashing of the error code LEDs on the front panel. The voltage at the noninverting inputs of U15 is about 11.35 volts while the voltage at the inverting input of U16 is about 6.52 volts. Note that the sensed voltage at U16 is first divided by two through R22.

Voltage regulator U14 is used to change the nominal –12.6V supply to –10V for use with the EEPROM control circuitry within the HP 85037 detectors. This voltage is required to allow the CPU to read and write to the EEPROM. It is controlled via the E2\_DATA\_EN line which shuts off the –12.6V supply. The –10V regulator then takes over. In normal use, U14 is reversed biased and is therefore essentially out of the circuit.

#### **D. RPG INTERFACE, RPG**

The RPG (rotary pulse generator) and the RPG interface allow the operator to change reference, scale, and other values with a rotary knob. The RPG outputs two TTL square wave pulse trains when it is rotated. The frequency of the pulse trains depends on how fast the RPG is turned, and the phase relation between the two pulse trains depends on the direction of rotation. The pulse trains are input to up/down counter U13. One line clocks U13 one count on its rising edge; the other controls the up/down input, causing the counter to increment when the line is high and decrement when the line is low at each rising clock. The A3 CPU reads the count from U13 on the data bus when requested via interrupts to determine how fast, and in which direction, the RPG is being turned. After reading U13 each time, the A3 CPU resets it to zero.

#### **E. KEYBOARD INTERFACE, KEYBOARD**

The front panel keyboard is electrically arranged in a matrix of six columns and eight rows. Any key press will generate an interrupt through U8. The A3 CPU detects the depressed key by writing to column strobing register U11A and reading row sensing buffer U10. If any row line is low, the A3 CPU can identify the row but not the column. Now the CPU writes high to KCOL0 through KCOL5 except low to one, and reads U10 again to see if the particular row is low. If so, the A3 CPU can now identify both row and column and pinpoint the key pressed. If not, the A3 CPU sets the next column low in sequence, until the column can be identified.

The A3 CPU performs pushbutton de-bouncing in firmware. During remote operation, the entire front panel is ignored except for the PRESET key. During remote operation with local lockout, the firmware also ignores the PRESET key.

## **F. DETECTOR BIAS/CONTROL**

LCL tee-filters reduce power supply noise to external accessories such as detectors or bridges. The accessories require these supplies to bias detectors and provide power supply voltages for preamplifiers. Note that filtering is referenced to chassis ground. A 10 ohm resistor in the power supply block connects chassis ground to analog ground to provide a DC return path when the front panel assembly is removed from the chassis frame. Detector control lines are clamped by diodes to the +15 volt and -12.6 volt supplies.

## **H. CONTROL REGISTERS**

The control registers further decode the data lines into 14 individual control signals. Included in these signals are the four control lines to the front panel LED's.

## **J. FRONT PANEL STATUS/INTERRUPT**

The A3 CPU senses RPG or keyboard activity through an interrupt from L SRQFP. Interrupts from the RPG are generated when U11B pin 6 is set high by the CPU. Keyboard interrupts are enabled by U11B pin 9. Strobing the keyboard or reading the RPG counter will clear the interrupt by resetting U1A or U1B. Detector supply overcurrent conditions will also generate an interrupt through U2A. PAL U7 handles the decoding of multiple lines to determine the correct interrupt conditions. The real time clock is also capable of generating an interrupt which is read through U7. U7 can also lock out the PRESET key if required during an HP-IB local lockout condition.

## **K, L. EEPROM DATA SELECT / EEPROM CLOCK GENERATOR**

This circuitry is used to communicate with the HP 85037 detectors. The EEPROM clock generates a 300KHz signal that is applied to the -12.6V supply to the detectors. This, together with the ability to change the -12.6V supply to -10V is how the CPU controls data flow and direction of flow to the detectors. The actual data is contained on the bidirectional control line (pin 3 of the detector). U3A is used to determine if the detector control voltage is above or below 2.5V which determines the direction of data flow. U3B, which senses voltage drop across the -12.6V supply inductors, is used to determine if any detector is connected.

## **DIAGNOSTIC TESTS**

Operator-initiated diagnostic tests for the front panel and front panel interface are accessed by pressing SYSTEM MORE SERVICE A1/2FP . This sequence presents a menu of tests that are described below.

In some cases, the analyzer can force a diagnostic test even if the front panel is not working. To access this feature, close the indicated status line switches on the A3 CPU and either press or momentarily short A3TP46 (L PRST) to ground.

Checks the rotary pulse generator (RPG) and its associated counter A2U13, as well as the address decoder and the RPG interrupt circuitry. The display shows the four-bit count in the RPG counter, and the last direction of RPG rotation. Turn the RPG slowly and check that the displayed count changes. Turn the RPG clockwise to increment the count, and counterclockwise to decrement the count. The counter will overflow from 1111 to 0000 or underflow from 0000 to 1111. The counter is not reset during this test, so the L CLR RPG line is not checked.

### READ KEY (Forced entry: Close A3S1-A and A3S1-C)

Tests the front panel key switches and key matrix, column strobing (A2U11A), row sensing (A2U10), associated address decoding (A2U5 and A2U7C), and the A3 CPU's ability to read keys. The keyboard interrupt circuitry is also checked whenever a key is pressed. Press any key except , and the CRT should display the name of the last key pressed. When a key is pressed or held, the display indicates \*ON. Softkeys are labeled on the right side of the display, except in the case of forced entry when no softkey labels are displayed. Press PRESET to exit this test.

### CYCLE (Forced entry: Close A3S1-C)

CYCLE exercises the front panel address decoding (A2U3, A2U4, A2U5) and data lines. All the address decoder lines used are briefly enabled by the A3 CPU. The A3 CPU also writes a data pattern to the column strobing latch A2U11A. Use an oscilloscope to check for activity similar to the waveforms shown in figure below. The cycle is approximately 9 ms long. All the front panel LEDs should light.

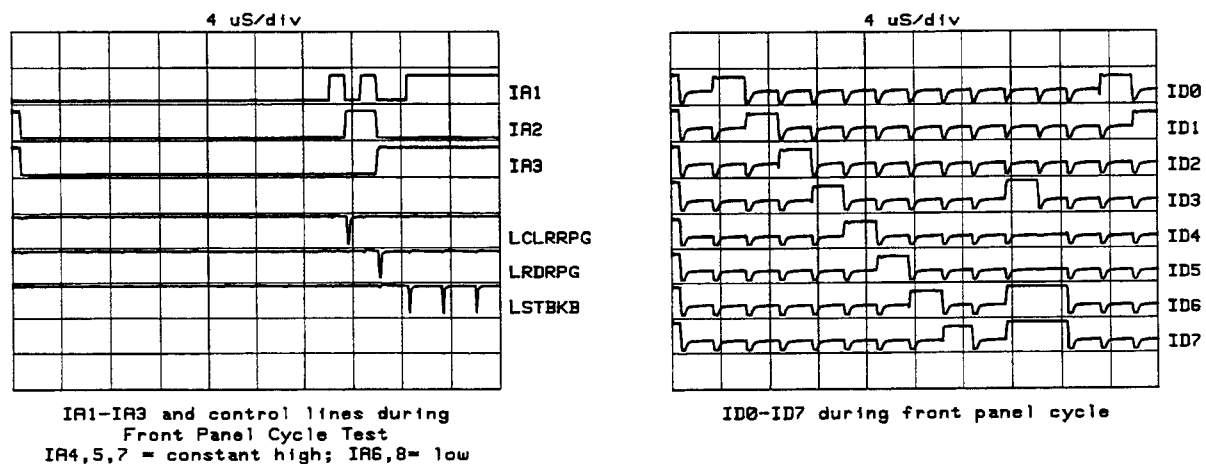


Figure 8-6. Front Panel Cycle Test Waveforms

### LEDS

This test exercises all the front panel LEDs, driver A2U12, and the address decoding. The LEDs light one at a time in sequence. The sequence repeats continuously. Visually check that all the LEDs light, in sequence, and one at a time.

## **PRESET DISABLE**

This test verifies the ability of PAL U7 to disable the preset key. Press PRESET, and verify that this has no effect. This preset lockout feature is used when the analyzer is in HP-IB local lockout mode.



## A1/A2 Troubleshooting

**NOTE:** The A1 front panel and A2 front panel interface assemblies are documented together. The troubleshooting information is organized functionally, treating parts of both assemblies together. To accommodate the mechanical mounting requirements of the LCD display, the A1 board has been divided into two parts, A1.1 and A1.2 as shown in figures 8-9 and 8-11.

Many diagnostic tests and simple front panel checks can be performed without removing the front panel from the chassis frame. If necessary, however, see "Front Panel Removal Procedure" following this troubleshooting information, to make disassembly and troubleshooting easier.

### BASIC CHECKS

The A1/A2 front panel circuits include keyboard functions, LED annunciators, and the RPG.

Turn on the line power or press PRESET to run the self-test procedure. If the self-test fails, four red LEDs on the A3 CPU will display an error code. The four front panel HP-IB STATUS LEDs and the display may also show error codes or error messages. See , "Self-Test And Main Error Code Summary" to interpret these results.

If the front panel LEDs or the display flash or blink randomly, see A3 CPU "Troubleshooting" and verify the A3 assembly. If the LEDs flash at a 1.5 Hz rate, it indicates a possible short circuit in one of the detectors connected to the front panel; remove detectors one at a time to determine the source of the fault.

Check for +5 V at TP5 (+5V). If it is missing, trace the problem back to the A12 power supply.

Check that the front panel interface cable W5 is correctly seated to the motherboard jack A11J1 and the front panel interface connector A2J1. Check that the bias cables W1-4 are properly seated. Check that the RPG wires are properly connected. Check that the front panel cable A1W1 is connected to A2.

### KEYBOARD AND INSTRUMENT BUS VERIFICATION

First verify the instrument bus connections between the A2 front panel interface and the A3 CPU. (All data lines between the A3 CPU and the A6 HP-IB, which are shared by the A2 front panel interface, are verified during self-test. If not, error code 13 is displayed.) If error code 13 appears, refer to A6 "Troubleshooting" and associated information. Correct the failure before proceeding with troubleshooting the A1/A2 front panel. All A1/A2 front panel functions depend on good instrument bus connections to the A3 CPU. Furthermore, most A1/A2 front panel diagnostic tests are accessed with the keyboard, and therefore require good keyboard interface connections.

If the keys and the display appear to be functioning, run the READ KEY diagnostic test. If this test cannot be called through the keyboard, close A3S1-A and A3S1-C, then press or ground A3TP46 (L PRST), to run the test. Press all keys and verify that the corresponding label for each appears on the display. If all the key labels are displayed, the instrument bus data lines to the front panel are completely verified.

If this check fails, verify the address lines to the A2 front panel interface by running the CYCLE test. If the keyboard does not function, close switch A3S1–C, then press PRESET or ground A3TP46 (L PRST) to run the test. While the front panel cycle test is running, all the address decoder outputs used are enabled in turn. Examine each with an oscilloscope for activity similar to the waveforms shown in Figure 8–3. If these waveforms are not present, trace the problem to A2U3, or trace the address lines back to the A3 CPU. Also check for activity on L IOSTB.

In addition, while the front panel cycle test is running, the A3 CPU writes a data pattern to the column strobing latch. Examine the outputs of A2U11 for a “walking 1” pattern. If this is missing, suspect A2U11 or the data line connections. The keyboard matrix itself can be tested with the front panel CYCLE test. (However, the front panel READ KEY diagnostic test is much easier, if it can be run.) The column strobing lines are automatically exercised. Press any key, and verify that the corresponding row sensing line follows the corresponding column strobing line. Use a dual trace oscilloscope to verify timing relationships and rule out shorts. When a key is pressed, a 7 ms upward pulse should be visible at the appropriate row sensing line. Use the rear panel CONTROL 1 output to trigger the oscilloscope. This makes it easier to check timing relationships.

## **LEDS**

If the LEDs appear burned out, press and hold preset. All LEDs, including the eight red LEDs on the A3 CPU, should light. If none of the LEDs light, check the preset functions and the L RESET line. If one LED does not light, suspect a bad LED.

Run the LEDS diagnostic test. All front panel LEDs should light, one at a time, in sequence. This test fully verifies LED address decoding and the data lines.

## **RPG (Rotary Pulse Generator)**

Run the READ RPG diagnostic test. The display indicates the present count from the RPG counter. (The RPG counter is reset upon entering the RPG test, but not again during the test.) Rotate the RPG clockwise to increment the count, counterclockwise to decrement the count. If the displayed count does not change, suspect the clock line of the RPG. Verify the counter U13 with an oscilloscope. If the direction of the count does not change, suspect the RPG’s up/down line.

Verify the RPG counter reset line, L CLRRPG, by exiting the read RPG test while the RPG counter indicates a count other than 0000. Re–enter the read RPG test and verify that the displayed count is now 0000.

## FRONT PANEL REMOVAL AND INSTALLATION PROCEDURE

The LCD assembly and the keypad assembly make up the front panel of the instrument. The LCD assembly must be removed before the keypad assembly can be removed. Refer to Figure 6-1 while performing these steps.

### REMOVING THE LCD ASSEMBLY:

1. Turn the power off!
2. Remove the top and bottom covers of the instrument by loosening the center screw at the rear of each cover.
3. Disconnect the LCD data cable (W10) from connector J6 on the front of the display interface board.
4. On the display interface board; slide the two ears on connector J7 toward you to release the flat flex cable (W11).
5. Remove the top trim strip from the instrument frame. (This will expose five screws; the screw in the middle fastens to the internal frame and should remain in place).
6. Remove the two top screws and the two bottom screws from the LCD assembly side of the instrument frame.
7. While holding the LCD assembly, rotate it slightly out of the frame.
8. Disconnect the small ribbon cable that connects the keypad assembly.

### REMOVING THE KEYPAD ASSEMBLY:

9. Remove the two top screws and the two bottom screws from the keypad assembly side of the instrument frame.
10. While holding the keypad assembly, rotate the top of it out of the frame.
11. Disconnect the ribbon cable (W5) at the motherboard.
12. Disconnect the detector interface cables (W1-W4) at the motherboard.
13. If the front of the keypad assembly has a connector labeled "POWER CAL OUT" it will be necessary to disconnect a cable from the modulator drive assembly Option 002 board. Lift the board up slightly and use a 15/64-inch wrench to loosen the connector.

### INSTALLING THE KEYPAD ASSEMBLY:

1. If the front of the keypad assembly has a connector labeled "POWER CAL OUT" it will be necessary to connect a cable to the modulator drive assembly Option 002 board. Lift the board up slightly and use a 15/64-inch wrench to tighten the connector.
2. Connect the detector interface cables (W1-W4) to the motherboard.
3. Connect the ribbon cable (W5) to the motherboard.
4. Place the keypad assembly into the frame and replace the four frame screws.

### INSTALLING THE LCD ASSEMBLY:

5. Connect the small ribbon cable that connects to the keypad assembly.
6. Place the LCD assembly into the frame, being careful not to pinch the flat flex cable.
7. Replace the four frame screws. (*Use the same screws that were removed earlier. Using screws that are too long can damage the LCD display.*)
8. Open the locking device on connector J7 on the display interface board.
9. Insert the flat flex cable (W11), with the metal conductive traces upward, into J7.
10. Close the locking device on connector J7.
11. Connect the LCD data cable (W10) to connector J6 on the display interface board.
12. Replace the top trim strip.
13. Replace the top and bottom covers.

*Table 8–6. A1/A2 Address Decoder Lines*

<b>Mnemonic</b>	<b>Address</b>	<b>Destination</b>	<b>Description</b>
L CLRRPG	1FF9B6	U13	Resets RPG counter
L RDRPG	1FF9B8	U13	Reads data from RPG counter
L STBKB	1FF9BA	U11	Writes data to Column Strobing register of keyboard
L SENKB	1FF9BE	U12	Reads data from Row Sensing buffer to sense keyboard
L WRLED	1FF9BE	U12	Writes data to LED register

**NOTE:** All data is contained on the least significant byte (D0 through D7).

Table 8-7. A1/A2 Pin-Outs

PIN	SIGNAL	I/O	SOURCE/ DESTINATION	FUNCTION BLOCK
1	+5V DIG	IN	A11J6-11	M
2	+5V DIG	IN	A11J6-11	M
3	GND DIG	IN	A11J6-6	M
4	GND DIG	IN	A11J6-6	M
5	ID1	I/O	A3P1-17	D,H
6	ID0	I/O	A3P1-18	D,H
7	ID3	I/O	A3P1-15	D,H
8	ID2	I/O	A3P1-16	D,H
9	ID5	I/O	A3P1-13	F,H
10	ID4	I/O	A3P1-14	D
11	ID7	I/O	A3P1-11	F,H
12	ID6	I/O	A3P1-12	F,H
13	IA7	IN	A3P1-60	A
14	IA8	IN	A3P1-61	A
15	IA5	IN	A3P1-21	A
16	IA6	IN	A3P1-20	A
17	IA3	IN	A3P1-23	A
18	IA4	IN	A3P1-22	A
19	IA1	IN	A3P1-25	A
20	IA2	IN	A3P1-24	A
21	L IOS	IN	A3P1-27	A
22	GND DIG	IN	A11J6-6	M
23	L RESET	IN	A3P1-31	A
24	GND DIG	IN	A11J1-31	M
25	L PRESET	OUT	A11J1-25	A
26	GND DIG	IN	A11J1-31	M
27	L SRQ FP	OUT	A11J1-27	K
28	GND DIG	IN	A11J1-31	M
29	NC			
30	GND DIG	IN	A11J1-31	M
31	CNTL A	OUT	A4P1-21	L
32	CNTL C	OUT	A4P1-24	L
33	CNTL R	OUT	A4P1-19	L
34	CNTL B	OUT	A4P1-20	L
35	+15V	IN	A11J6-14	M
36	+15V	IN	A11J6-14	M
37	GND PLANE	IN	A11J6-4	M
38	GND PLANE	IN	A11J6-4	M
39	-12.6V	IN	A11J6-10	M
40	-12.6 V	IN	A11J6-10	M

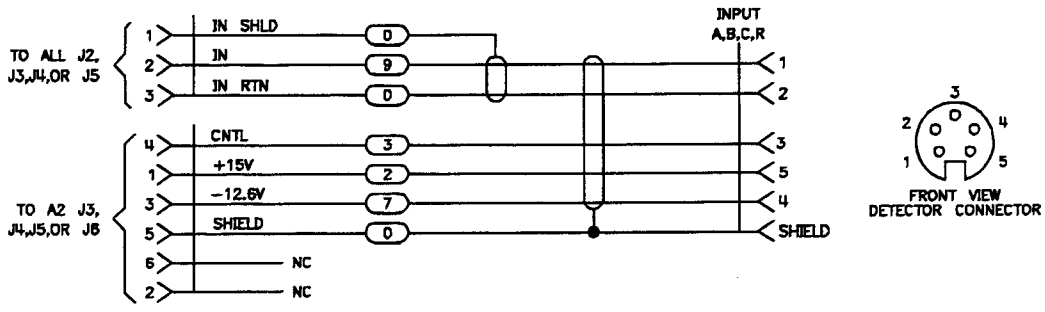


Figure 8-8. W1-4 Detector Interface Cable Schematic

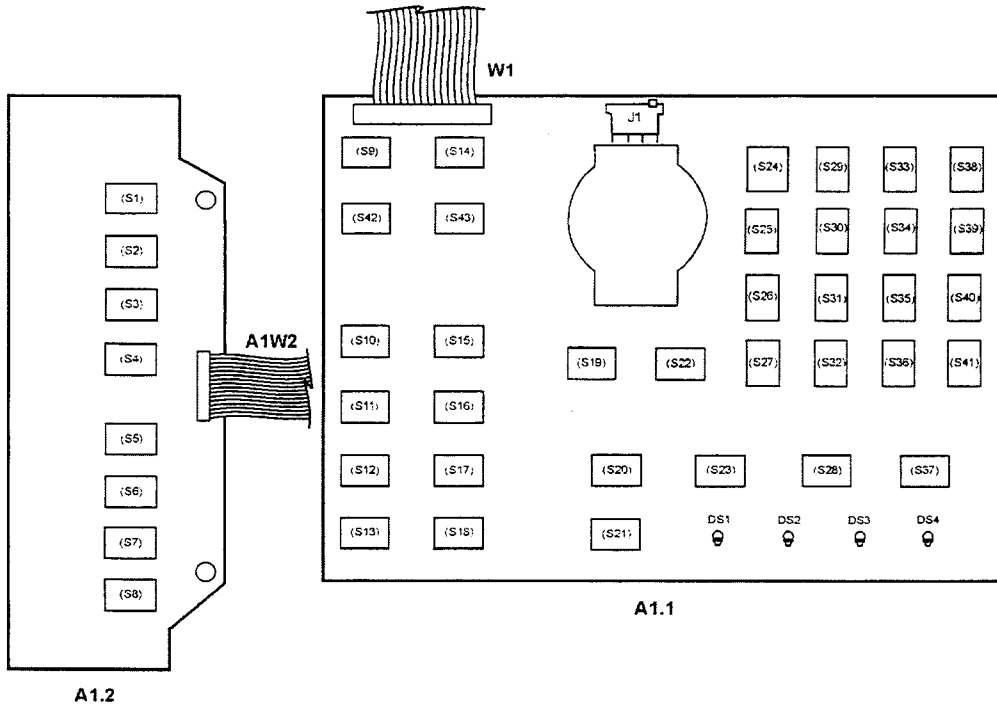
*Replaceable Parts List for A2 Assembly (1 of 2)*

Reference Designation	HP Part Number	Qty	Description	Mfr Code	Mfr Part Number
A2	08757-60113	1	BD AY-FP INTRFC	28480	08757-60113
A2C1	0180-3849	1	CAP-FXD 47uF ±10% 10 V TA	04200	299D476X9010DB1
A2C2	0160-4084	1	CAP-FXD 0.1uF ±20% 50 V CER X7R	09939	RPE122-139X7R104M50V
A2C3-C8	0180-3845	1	CAP-FXD 4.7uF ±10% 35 V TA	04200	299D475X9035CB1
A2C9-C16	0160-4084	1	CAP-FXD 0.1uF ±20% 50 V CER X7R	09939	RPE122-139X7R104M50V
A2C17-C18	0180-3845	1	CAP-FXD 4.7uF ±10% 35 V TA	04200	299D475X9035CB1
A2C19	0160-4801	1	CAP-FXD 100pF ±5% 100 V CER C0G	09939	RPA10C0G101J100V
A2C20	0160-4441	1	CAP-FXD 0.47uF ±10% 50 V CER X7R	09939	RPE113-130X7R474K50V
A2C21	0160-4832	1	CAP-FXD 0.1uF ±20% 100 V CER X7R	09939	RPE122-139X7R104M50V
A2C22	0160-4084	1	CAP-FXD 0.1uF ±20% 50 V CER X7R	09939	RPE122-139X7R104M50V
A2C23-C24	0180-3845	1	CAP-FXD 4.7uF ±10% 35 V TA	04200	299D475X9035CB1
A2C25-C26	0160-4441	1	CAP-FXD 0.47uF ±10% 50 V CER X7R	09939	RPE113-130X7R474K50V
A2C27-C28	0160-4084	1	CAP-FXD 0.1uF ±20% 50 V CER X7R	09939	RPE122-139X7R104M50V
A2C29	0180-3770	1	CAP-FXD 2.2uF ±10% 35 V TA	04200	299D225X9035BB1
A2C30	0160-4801	1	CAP-FXD 100pF ±5% 100 V CER C0G	09939	RPA10C0G101J100V
A2CR1-CR7	1901-0050	1	DIODE-SWITCHING 80V 200MA 2NS DO-35	03406	
A2CR8	1901-0731	1	DIODE-PWR RECT 400V 1A	02037	1N4004
A2CR9-CR15	1901-0050	1	DIODE-SWITCHING 80V 200MA 2NS DO-35	03406	
A2CR16	1901-0518	1	DIODE-SCHOTTKY SM SIG	02062	5082-5509
A2CR17	1901-0050	1	DIODE-SWITCHING 80V 200MA 2NS DO-35	03406	
A2CR18	1901-0518	1	DIODE-SCHOTTKY SM SIG	02062	5082-5509
A2DL1	1810-1272	1	DELAY LINE ACTIVE DEVICE W/DUAL IN-LINE	12186	DS1000M-100
A2J1	1251-8828	1	CONN-POST TYPE .100-PIN-SPCG 40-CONT	04726	2540-6002UB
A2J2	1251-8248	1	CONN-POST TYPE .100-PIN-SPCG 26-CONT	04726	2526-6002UB
A2J3-J6	1251-6515	1	CONN-POST TYPE .100-PIN-SPCG 6-CONT	02946	67996-606
A2L1	08503-80001	1	COIL-TORROID		
A2L2	9100-2573	1	INDUCTOR RF-CH-MLD 1MH ±10%	28480	9100-2573
A2L3	9100-2578	1	INDUCTOR RF-CH-MLD 2.7MH ±10%	28480	9100-2578
A2L4	9100-2573	1	INDUCTOR RF-CH-MLD 1MH ±10%	28480	9100-2573
A2L5	9100-2578	1	INDUCTOR RF-CH-MLD 2.7MH ±10%	28480	9100-2578
A2L6	9100-2573	1	INDUCTOR RF-CH-MLD 1MH ±10%	28480	9100-2573
A2L7	9100-2578	1	INDUCTOR RF-CH-MLD 2.7MH ±10%	28480	9100-2578
A2L8	9100-2573	1	INDUCTOR RF-CH-MLD 1MH ±10%	28480	9100-2573
A2L9	9100-2578	1	INDUCTOR RF-CH-MLD 2.7MH ±10%	28480	9100-2578
A2L10	9100-2573	1	INDUCTOR RF-CH-MLD 1MH ±10%	28480	9100-2573
A2L11	9100-2578	1	INDUCTOR RF-CH-MLD 2.7MH ±10%	28480	9100-2578
A2L12	9100-2573	1	INDUCTOR RF-CH-MLD 1MH ±10%	28480	9100-2573
A2L13	9100-2578	1	INDUCTOR RF-CH-MLD 2.7MH ±10%	28480	9100-2578
A2L14	9100-2573	1	INDUCTOR RF-CH-MLD 1MH ±10%	28480	9100-2573
A2L15	9100-2578	1	INDUCTOR RF-CH-MLD 2.7MH ±10%	28480	9100-2578
A2L16	9100-2573	1	INDUCTOR RF-CH-MLD 1MH ±10%	28480	9100-2573
A2L17	9100-2578	1	INDUCTOR RF-CH-MLD 2.7MH ±10%	28480	9100-2578
A2MP2	0380-1247	4	SPACER-RVT-ON 8-MM-LG 3.8-MM-ID	02121	0380-1247
A2Q1	1855-0567	1	TRANSISTOR MOSFET P-CHAN E-MODE SI	03038	IRFD9123
A2Q3	1855-0518	1	TRANSISTOR MOSFET N-CHAN E-MODE SI	03038	IRFD110
A2Q4-Q6	1853-0007	1	TRANSISTOR PNP 2N3251 SI TO-18 PD=360MW	02037	2N3251
A2Q7	1854-0477	1	TRANSISTOR NPN 2N2222A SI TO-18 PD=500MW	02037	2N2222A
A2R1	0757-0401	1	RESISTOR 100 ±1% .125W TF TC=0±100	05524	
A2R2	0698-3155	1	RESISTOR 4.64K ±1% .125W TF TC=0±100	05524	
A2R3	0757-0346	1	RESISTOR 10 ±1% .125W TF TC=0±100	05524	
A2R4	1810-0374	1	NETWORK-RES 8-SIP 1.0K OHM X 4	02483	750-83-R1K
A2R5	0698-3162	1	RESISTOR 46.4K ±1% .125W TF TC=0±100	05524	

*Replaceable Parts List for A2 Assembly (2 of 2)*

Reference Designation	HP Part Number	Qty	Description	Mfr Code	Mfr Part Number
A2R6	0698-3446	1	RESISTOR 383 ±1% .125W TF TC=0±100	05524	
A2R8-R9	0757-0401	1	RESISTOR 100 ±1% .125W TF TC=0±100	05524	
A2R10	0698-3403	1	RESISTOR 348 ±1% .5W TF TC=0±100	05524	
A2R11	0757-0442	1	RESISTOR 10K ±1% .125W TF TC=0±100	05524	
A2R12	0698-3162	1	RESISTOR 46.4K ±1% .125W TF TC=0±100	05524	
A2R13	1810-0279	1	NETWORK-RES 10-SIP 4.7K OHM X 9	05524	MSP10A01-472G
A2R14	0757-0442	1	RESISTOR 10K ±1% .125W TF TC=0±100	05524	
A2R15	0757-0443	1	RESISTOR 11K ±1% .125W TF TC=0±100	05524	
A2R16	0698-4474	1	RESISTOR 8.45K ±1% .125W TF TC=0±100	05524	
A2R17	0757-0438	1	RESISTOR 5.11K ±1% .125W TF TC=0±100	05524	
A2R18-R21	0698-3162	1	RESISTOR 46.4K ±1% .125W TF TC=0±100	05524	
A2R22	1810-0316	1	NETWORK-RES 16-DIP 10.0K OHM X 8	02483	761-3-R10K
A2R23-R24	0698-3155	1	RESISTOR 4.64K ±1% .125W TF TC=0±100	05524	
A2R25-R30	0698-3155	1	RESISTOR 4.64K ±1% .125W TF TC=0±100	05524	
A2R31	0757-0442	1	RESISTOR 10K ±1% .125W TF TC=0±100	05524	
A2R32	0757-0279	1	RESISTOR 3.16K ±1% .125W TF TC=0±100	05524	
A2R33-R34	0757-3160	1	RESISTOR 31.6K ±1% .125W TF TC=0±100	05524	
A2R35	0757-0443	1	RESISTOR 11K ±1% .125W TF TC=0±100	05524	
A2R36	0757-0123	1	RESISTOR 34.8K ±1% .125W TF TC=0±100	05524	
A2R37-R38	0757-0442	1	RESISTOR 10K ±1% .125W TF TC=0±100	05524	
A2R39	0757-0443	1	RESISTOR 11K ±1% .125W TF TC=0±100	05524	
A2R40	0698-3260	1	RESISTOR 464K ±1% .125W TF TC=0±100	05524	
A2R41	0698-3446	1	RESISTOR 383 ±1% .125W TF TC=0±100	05524	
A2R42	0757-0280	1	RESISTOR 1K ±1% .125W TF TC=0±100	05524	
A2R43	0757-0438	1	RESISTOR 5.11K ±1% .125W TF TC=0±100	05524	
A2R44-R46	0757-0442	1	RESISTOR 10K ±1% .125W TF TC=0±100	05524	
A2R47	0757-0403	1	RESISTOR 121 ±1% .125W TF TC=0±100	05524	
A2R48	0757-0199	1	RESISTOR 21.5K ±1% .125W TF TC=0±100	05524	
A2R49	0698-3162	1	RESISTOR 46.4K ±1% .125W TF TC=0±100	05524	
A2R50	0698-3155	1	RESISTOR 4.64K ±1% .125W TF TC=0±100	05524	
A2R51	0698-3438	1	RESISTOR 147 ±1% .125W TF TC=0±100	05524	
A2R52	0698-0083	1	RESISTOR 1.96K ±1% .125W TF TC=0±100	05524	
A2R53	0698-0083	1	RESISTOR 1.96K ±1% .125W TF TC=0±100	05524	
A2TP1-TP7	1460-2201	1	SPRING RADIAL TEST POINT		
A2U1-U2	1820-2488	1	IC FF TTL/ALS D-TYPE POS-EDGE-TRIG	01698	SN74ALS74AN
A2U3	1826-0666	1	IC COMPARATOR LOW-OFS QUAD 14 PIN DIP-P	03406	LM339AN
A2U4	1826-2331	1	ANALOG MULTIPLEXER 4 CHNL 16 -DIP-P	02883	DG409DJ
A2U5	1820-3100	1	IC DCDR TTL/ALS BIN 3-TO-8-LINE 3-INP	01698	SN74ALS138N
A2U6	1820-3318	1	IC FF TTL/ALS D-TYPE POS-EDGE-TRIG COM	01698	SN74ALS273N
A2U7	08757-80077	1	PAL A2U7		
A2U8	1820-2773	1	IC GATE TTL/ALS NAND 8-INP	01698	SN74ALS30AN
A2U9-U10	1820-3145	1	IC DRVR TTL/ALS BUS OCTL	01698	SN74ALS244BN
A2U11-U12	1820-3318	1	IC FF TTL/ALS D-TYPE POS-EDGE-TRIG COM	01698	SN74ALS273N
A2U13	1820-3217	1	IC CNTR TTL/ALS BIN UP/DOWN SYNCHRO	01698	SN74ALS569AN
A2U14	1826-0994	1	IC V RGLTR-ADJ-NEG 1.2/37V 8-TO-92 PKG	03406	LM337LZ
A2U15-U16	1826-0138	1	IC COMPARATOR GP QUAD 14 PIN DIP-P	03406	LM339N
A2U17	1820-3505	1	IC CNTR TTL/ALS BIN UP/DOWN SYNCHRO	01698	SN74ALS191N
A2U18	1813-0863	1	CLK-OSC-XTAL STD 2.4576-MHZ 0.01%	12768	SG-531P-2.4576MHZ
A2U19	08757-80078	1	PAL A2U19		
A2U20	1820-3121	1	IC TRANSCEIVER TTL/ALS BUS OCTL	01698	SN74ALS245AN
A2U21	1826-2068	1	IC MISC 24 PIN DIP-P	12186	DS1287
A2VR1-VR16	1902-0956	1	DIODE-ZNR 8.2V 5% DO-35 PD=.4W TC=+.065C> 02037	SZ30035-1	





sa612d

Figure 8-9. A1 Component Locations Diagram

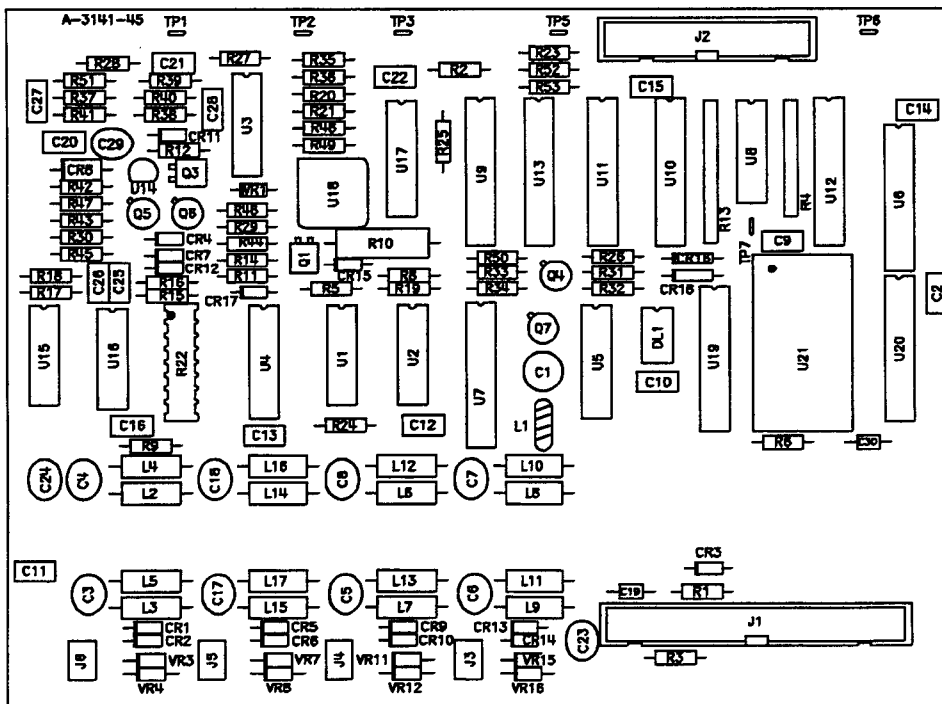


Figure 8-10. A2 Component Locations Diagram

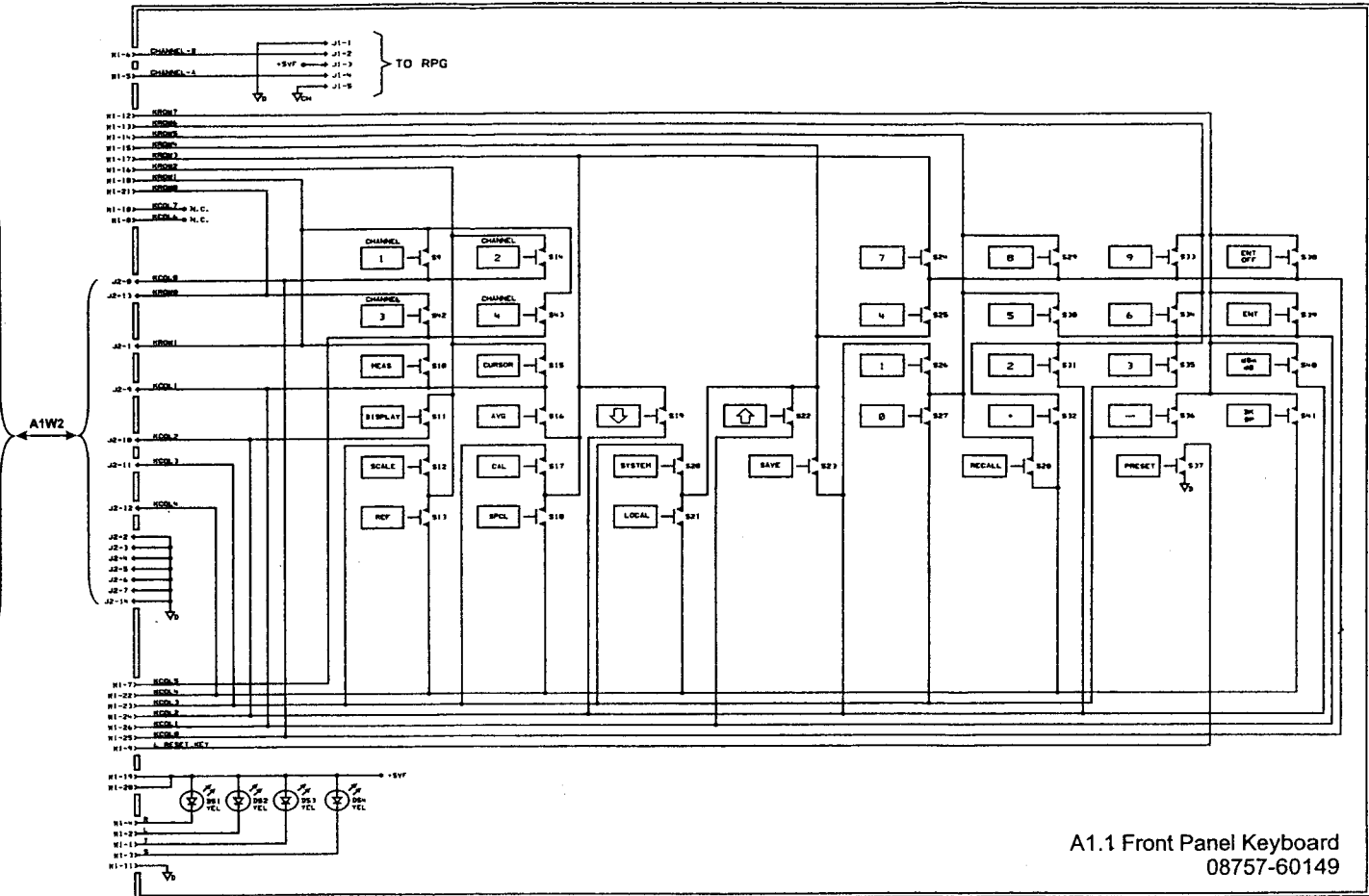
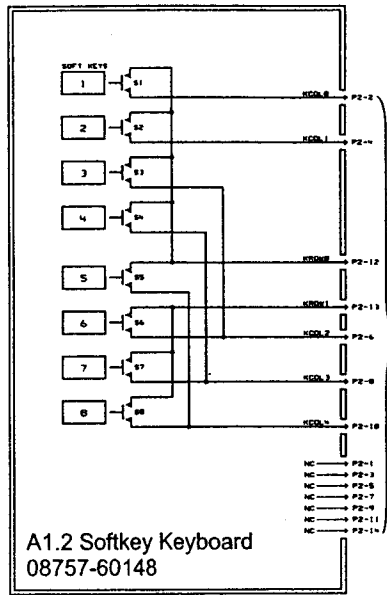
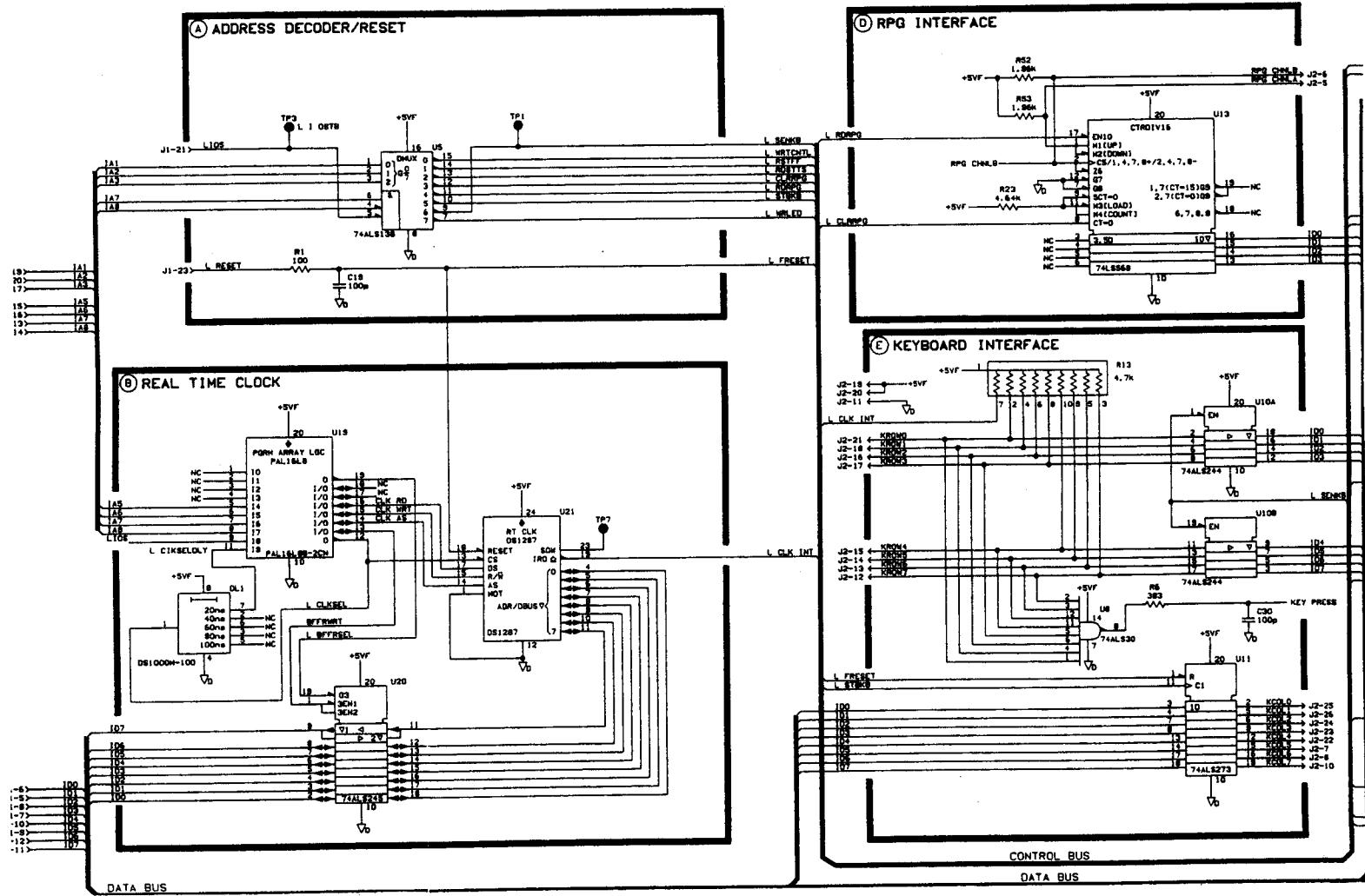
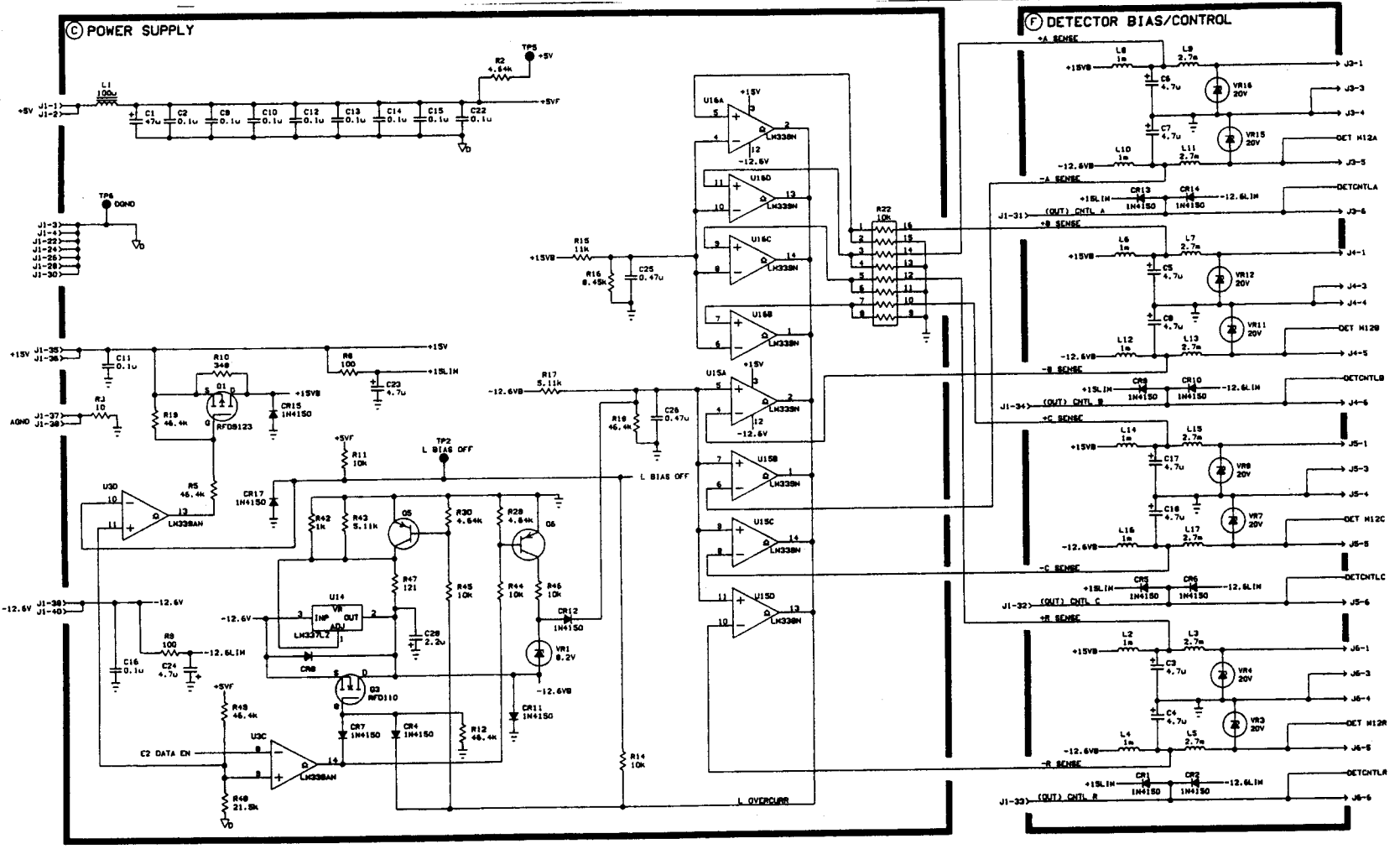
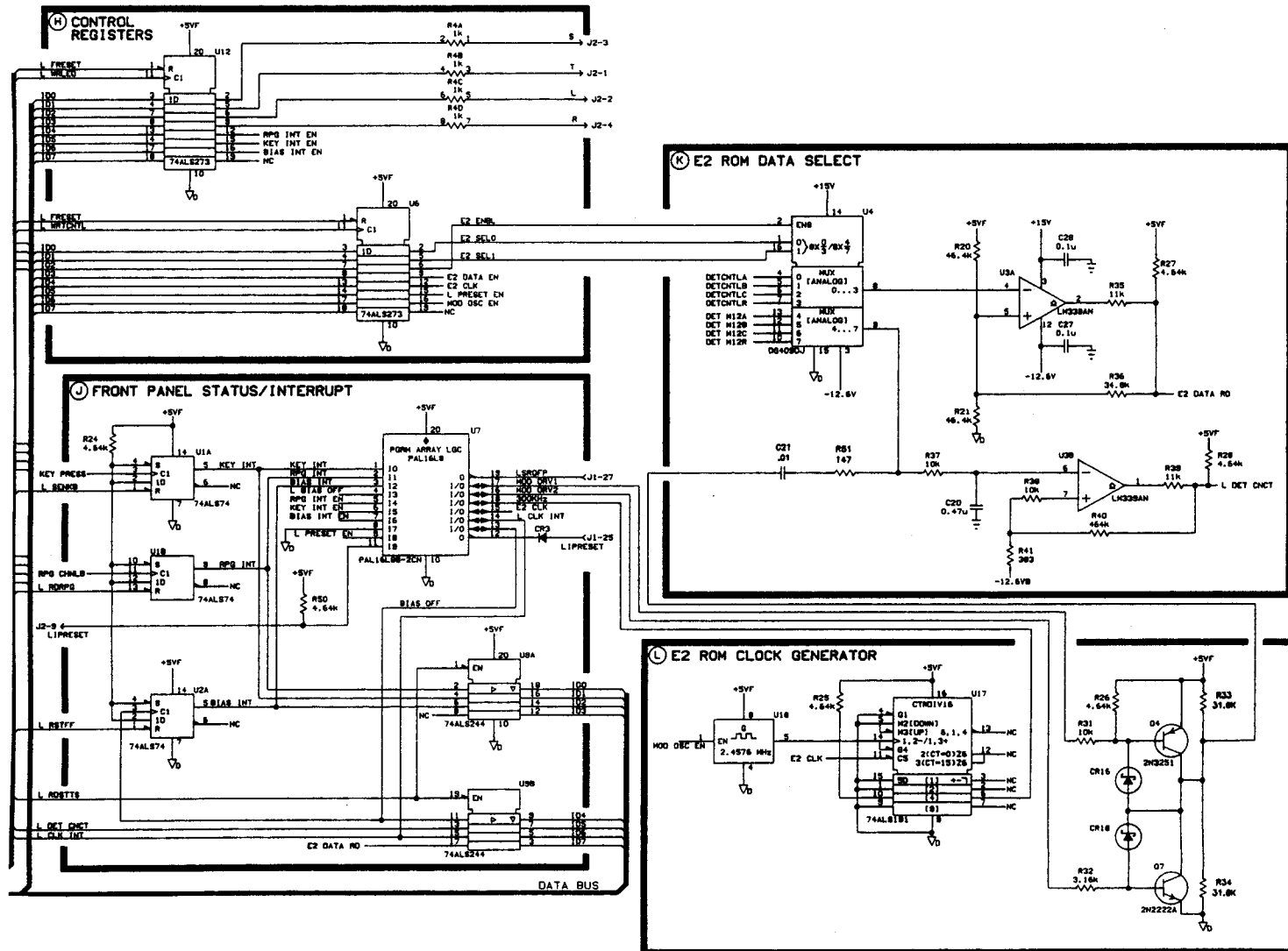


Fig. 8-11 (1 of 2) A1 Front Panel Schematic Diagram

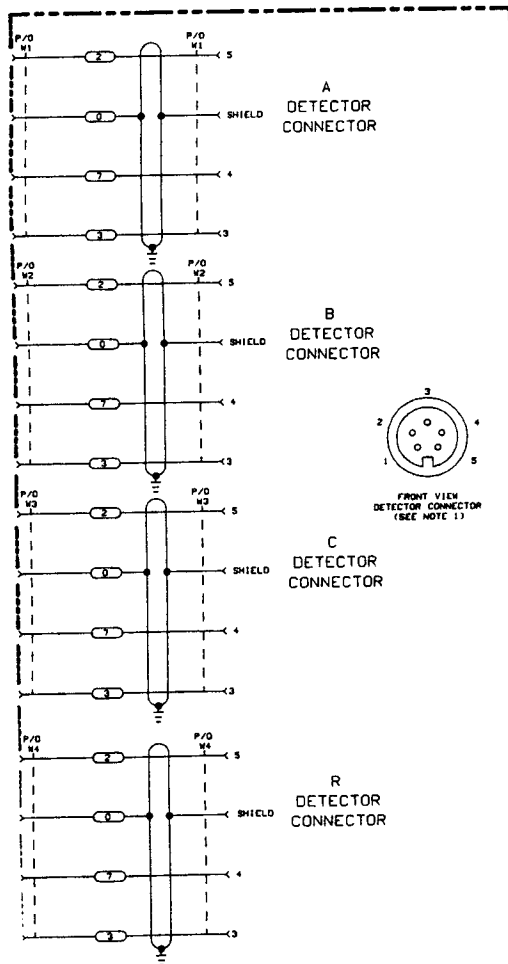




2 of 4 Bottom Left of Drawing



3 of 4 Top Right of Drawing



NOTE 1: FRONT PANEL DETECTOR INPUT CONNECTOR IS PART OF CABLE ASSEMBLIES N1-4. ORDER ENTIRE ASSEMBLY IF ANY PART REQUIRES REPLACEMENT.

## A2 FRONT PANEL INTERFACE

08757-60113

Figure 8-11. A2 Front Panel Interface, Schematic Diagram (2 of 2)

## A3 Central Processing Unit (CPU)

### CIRCUIT DESCRIPTION

The A3 CPU has digital control of all major assemblies in the instrument. Its microprocessor executes internal program code to read the A, B, C, and R inputs through the A4 ADC; to format the data for the A15 display; to receive commands through the A1/A2 front panel; and to communicate with other instruments or a controller through two ports on the A6 HP-IB assembly.

#### A. CLOCK

The clock generator generates the 10 MHz, 1 MHz, and 200 kHz clock signals used by the CPU, and the 5 MHz clock signal used for the A6 HP-IB assembly.

Oscillator U14 is a TTL buffered 20 MHz free-running crystal oscillator. Counter U15 divides the 20 MHz clock into slower clock signals. The 10 MHz clock is the main system clock for the microprocessor. This signal is also inverted by U25B and is phase shifted by U25A. These two signals are used in the IO timing circuit. The 2 MHz output of U15 drives another divider, U41, to obtain the 1 MHz and 200 kHz timing signals for the timer circuit.

#### B. POWER-ON/PRESET

The power-on/preset circuit resets the microprocessor when the front panel **PRESET** key is pressed. It also controls the power-up sequence.

One-shot timer U13 resets the microprocessor. At power on, C24 keeps U13 pin 2 low momentarily. Then U13 fires to set U13 pin 3 high for about 500 ms and pull L HALT and L MPRESET low to reset the microprocessor. The front panel **PRESET** key also triggers U13, resetting the microprocessor. When the instrument is powered down, an interrupt signal will also generate a reset through CR1 after about 1 ms.

L MPRESET is bidirectional (either U12D or microprocessor U9 can pull it low.) U24E and U38A buffer L MPRESET to output L RESET. When low, L RESET resets most major assemblies throughout the instrument to a known state. This occurs at power-on, at preset, or at a microprocessor-forced reset.

#### C. STATUS/INTERRUPT

The status/interrupt circuitry provides important inputs for the microprocessor: status information, and interrupt source and priority.

Three-state buffer U3 reads status information to the microprocessor on the data bus. When L CPUSTTS goes low, U3 buffers its inputs onto the data bus. Four of the status lines are used to initiate different self-test routines (via S1). See Table 8-3, "Forced Diagnostic Tests" for details. One status line is used to determine if the EEPROMs are write enabled, one to determine if any power supply has failed, and two others read the presence of jumpers W1 and W2.

Eight-to-three priority encoder U22 handles interrupts. When one of its eight inputs goes low, U22 encodes the input number on three binary weighted output lines: L IPL0, L IPL1, and L IPL2. If more than one input is low, U22 outputs the highest priority level code. L PF INT has the highest priority and indicates the line power has been disconnected. L DRINT goes low when an analog-to-digital conversion from the A4 ADC assembly is ready. L SRQA and L SRQB go low to request service for the HP interface bus and 8757 system interface, respectively, on the A6 HP-IB assembly. L SRQFP indicates front panel activity, and L STTS INT can indicate one of several conditions from the A4 ADC assembly.

Other sources of interrupts are OR'd together with U21 and have the lowest priority. In order to determine which circuit initiated the interrupt, U19 reads the individual inputs to U21.

## D. MICROPROCESSOR

The microprocessor is the heart of the A3 CPU assembly. It controls the entire analyzer, including data input and output operations, and mathematical calculations.

U9 is an MC68000 sixteen-bit microprocessor. It has 23 address lines, although only 20 of them are used to form the address bus. Binary weighted lines A1 through A20 specify an address for the source or destination of data in read or write operations. Test points are available for all the address lines used.

Data lines D0 through D15 form the sixteen-bit data bus. The data bus is bidirectional, and carries data to or from U9. Test points are available for all data lines. U9 pin 9 generates the L WRITE and L READ lines. These control the direction of data transfer on the data bus. (READ always means that U9 is taking in data that some other device has put on the data bus. WRITE always means that U9 is putting out data on the data bus for another device to take in.) U9 pin 6 generates ASTRB (address strobe). ASTRB goes high when the address on the address bus is settled and valid. U9 pins 7 and 8 generate L WRMSB (L =write most significant bits) and L WRLSB (L =write least significant bits). These lines are active when U9 is accessing only eight of its sixteen data lines. (See the following note.)

U9 pin 10 receives the L DTACK (L =data acknowledge) line from I/O timing and U10. L DTACK goes low when data has been received from the data bus. It signals the end of a read or write cycle. See "J. I/O Timing" for details.

**NOTE:** Address bit A0, the least significant bit, is internal to U9, but it does not appear at a pin and is not part of the address bus. It is used in U9 during eight-bit *byte* operations. When A0 is 1, U9 reads or writes to the least significant data bits D0 through D7. When A0 is 0, U9 reads or writes to the most significant data bits D8 through D15. Byte operations are indicated on U9 pins 7 and 8. During troubleshooting or when using hex data read/write, assume that only full sixteen-bit *word* operations are used, A0 is 0, and all hex addresses are even.

Free run jumper U18 is used during troubleshooting to verify the microprocessor kernel. When U18 is removed, six data line paths are broken. U11B, C, and D, pull D12, D13, and D14 high. U12A, B, and C pull D0, D8, and D15 low. This causes U9 to read a program instruction repeatedly to assist in troubleshooting.



## E. ADDRESS DECODER

The address decoder decodes the more significant address lines into control lines that enable major blocks of memory or addressable input/output lines. Refer to Table 8–11 for address space allocations, major address decoder lines, destinations, and descriptions. The logic array used for address decoding is also used for determining the proper number of wait states for the data acknowledge line (DTACK) (see “J. I/O Timing”).

## F. ROM

The ROM (read only memory) stores program data and data constants for the microprocessor to read.

The ROM consists of four 128Kx8 EPROM packages arranged in two pairs to form sixteen-bit words. Each pair is enabled to output data when the appropriate enable line goes low. L ROM must go low to enable the ROMs. Seventeen address lines, A1 through A17, select one of the 128K memory locations within each device. The eight data lines have three-state outputs. Only two of the four possible EPROMs are used. Future firmware upgrades may require all four EPROMs.

## G. EEPROM

The EEPROM (electrically erasable programmable read only memory), also known as EEROM, is used as the non-volatile storage location for the calibration constants of all the log amplifier assemblies and option 002 cal constants. Data can be read from it as often as desired, but data can be written to it only a limited number of times. The EEPROM consists of two 2Kx8 packages arranged to form sixteen-bit words. It is enabled when L EEPROM goes low. Data cannot be written to it unless the switch A3S1–E is closed.



**The EEPROM contains all the calibration data for all the log amplifiers and the option 002 calibrator. NEVER leave switch A3S1–E in the closed position unless you are recalibrating the entire HP 8757 using the HP 11613A/B calibrator, or running the EEROM test, as all the calibration data may be lost.**

**Data can be written to any given location of EEPROM only a limited number of times (typically >10,000 times). Never perform a hex data rotate at an EEPROM location (hex 0C0000 to 0FFFFE) while the switch is closed. This will quickly destroy the memory retention capability of that location on both EEPROM packages.**

Eleven address lines select one of the 2K memory locations within each device. All data lines have three-state outputs.

## H. RAM

The RAM (random access memory) is the read and write memory for storing variables. The RAM is protected against power failure by a battery.

The RAM consists of four 32Kx8 memory chips arranged in two pairs to form sixteen-bit words. Each of the four devices is enabled when the appropriate enable line goes low. L READ goes low to read from RAM. All reads are sixteen bits. L WRMSB goes low for writes to the eight most significant bits; and L WRLSB goes low for writes to the eight least significant bits. Writes can be either eight or sixteen bits. Fifteen address lines, A1 through A15, define the 32K memory locations within each device. The data lines have three-state inputs or outputs.

All RAM is protected against data loss during power failure or power off. A battery on the A3 CPU assembly provides the supply voltage to the RAM when the +5VF supply fails. See "M. Power Supply Filtering" for details.

## J. I/O TIMING

The I/O timing circuitry controls the timing of data input and output operations and, with the address decoder array logic, generates the L DTACK and L IOS lines. L DTACK goes low either to acknowledge data that has been put on the data bus for the microprocessor by another device (read); or to acknowledge that data has been received from the microprocessor by another device (write). L IOS goes low either to enable devices on the instrument bus to output data on the data bus for the microprocessor (read); or to clock in data from the data bus on either the falling or the rising edge (write).

Shift register U42 and counter U43 form a digital delay line. 10 MHz clocks the shift registers. ASTRB controls the reset pin of the shift register and, in turn, the counter. ASTRB is inactive low, resetting U42 so that all outputs are low. During a read or write operation, the microprocessor establishes the address on the address bus, then sets ASTRB high to indicate a valid address. This allows U42 to clock in a logic high and propagate it through U42. Then each output from U42 goes high a specific time after ASTRB goes high. The delay between successive outputs is 100 ns, with a maximum of 7 wait states before the logic high is transferred to U43, where 15 more wait states are counted before W22 goes high. After pin 15 of U43 goes high the counter is inhibited from further counting until it is reset.

Different devices send or receive data on the data bus at different speeds. To optimize microprocessor speed, the time duration of each read or write operation—from ASTRB going high to L DTACK going low—is matched to the speed of the devices involved in the data transfer. The delayed outputs from U42/43 are selected at U31 and U32 by address decoder enable lines. Thus, each block of address has its own characteristic L DTACK delay and read/write cycle length.

In troubleshooting, U18 is removed for the free run test. R2 pulls L DTACK low continuously, causing the shortest possible read/write cycles. If required for troubleshooting, TP6 (LDT) may be connected to TP44 (LW22) to force a long and fixed L DTACK delay.

L IOS controls the timing of data transfers with assemblies other than A3 CPU. It goes low to enable three-state outputs during read operations, and its falling or rising edge triggers latches during write operations.

## K. TIMER

U36 provides a method for timing several different events. Programmable timer U36 provides three separate timers: one is clocked at 1 MHz and the other two at 200 kHz. Each can be programmed to provide an interrupt after a preset time, up to 65535 clock cycles. Interrupts are enabled via U39 and U38. Another interrupt is programmable through U40C and is used for self-testing the interrupt circuitry.

L 27K MOD DR turns the A5 modulator on and off. Two user control lines to the rear panel are buffered by U40A and U12B. These lines are user programmable and are also used in troubleshooting.

## L. INSTRUMENT BUS INTERFACE

The instrument bus interface buffers the data bus and address bus lines before they leave the A3 CPU assembly. The microprocessor controls the rest of the analyzer through the instrument bus.

Octal register U37 latches eight address lines, A1 through A8, when LIO goes low. The latched address stays on the instrument bus throughout the LIO cycle and until a new address is latched. These address lines, together with the enable lines L DISP and L WRITE, determine the source (read) or destination (write) of data during an IO operation.

Bidirectional three-state buffers U34 and U35 buffer the sixteen data lines of the instrument bus. L IO enables the three-state buffers. L WRITE controls the direction of data flow.

Several control lines leave the A3 CPU assembly to become part of the instrument bus. L RESET resets most major assemblies during power-on or preset. L WRITE controls the direction of data flow. L IOS controls timing of I/O operations.

## M. POWER SUPPLY FILTERING

The power supply filtering circuitry reduces digital noise on the +5VDIG voltage supply lines. It also includes the battery supply for the RAM. This battery is a lithium iodide with a nominal voltage of 2.8 V. Typical lifetime of the battery is about 10 years.

C23, L1, and C22 form a pi Chapter filter to remove noise from the +5VDIG and +5VF voltage supply lines. Additional capacitors provide local filtering.

If the analyzer power is turned off, the L PFW line generates a top priority interrupt to signal the CPU to power down. As the +5 V drops, U24 will signal the CPU that power is off. R6 will pull the input to U24 low if the board is removed from the instrument with power still on. U16 and U17 provide both power and device selection signal to the RAM. These ICs automatically switch power from the 5 volt supply to the battery when power is turned off. In addition, it ensures that the RAM is not selected during the power down sequence. U16 and U17 control power and access to two RAMs each.

## Diagnostic Tests

Several operator-initiated diagnostic tests are available to help troubleshoot the A3 CPU assembly. These can be accessed by pressing **SYSTEM MORE SERVICE A3 CPU**. However, if the CPU board is not working, these tests may be inaccessible. Some of these tests can be forced to run by setting the status switches on the CPU board. With these switches set, the CPU will immediately run the designated test upon power-up or preset.

### RAM TEST

This test performs a memory test on the RAM without destroying the data it contains. A known pattern is written to each location in RAM and then read back. Any bit position that fails is displayed on the CRT. This test is also used by the instrument before displaying error code 13. Because of the length of this test, it is *only* run during power-up and instrument verify; not during an instrument preset.

### TIMER

The timer test checks the ability of the programmable timer consisting of U36 and its associated circuitry. Because it is digital, it cannot test for accuracy; just functionality. Accuracy is determined by the accuracy of the 20 MHz clock and its associated circuitry.

### EEROM TEST



**This test can destroy calibration data stored in EEPROM. Perform this test only if absolutely necessary. Read all instructions carefully.**

All calibration data is stored in EEPROM (also referred to as EEROM). This test verifies the short term ability of the EEPROM to store and retrieve memory. This test should only be performed if there is serious doubt about the operation or data retention ability of the EEPROM, such as when the error message **WARNING: Default calibration table used on input x** occurs. During this test the existing calibration data is temporarily transferred to RAM for later restoration. However, this data will be lost from RAM if power is lost or if an instrument preset is performed. In this case, perform a recalibration using the HP 11613A/B calibrator. If the instrument is an option 002, other equipment will also be needed.

In order for the EEPROM test to pass, switch A3S1-E must be closed. Start the test by pressing the soft key **EXECUTE**. The routine takes about one minute. Once the test is begun, do *not* attempt to abort it. A data pattern is written to and read back from each address location in EEPROM. When the test is complete, a **PASS** or **FAIL** message is displayed on the CRT. Troubleshoot by checking the continuity of all data lines, and the proper operation (signatures) of all control lines. If these appear correct, suspect either or both of the EEPROMs U4 and U26. If either of these EEPROMs are replaced, recalibrate the analyzer using the appropriate equipment.

## READ STATUS

This cycle test continuously reads and displays the output of the status register U3. Grounding one of the inputs of U3 should cause one of the displayed status bits to change to logic 0. Troubleshoot by momentarily grounding each input of U3 and checking that the corresponding status bit changes from 1 to 0 on the CRT. Status lines 0 through 4 can be grounded by closing switches A3S1A–E. If all the bits fail, check the control lines of U3 or suspect that U3 itself is defective.

## INTRPT (Forced Entry: Close switch A3S1–B and A3S1–C)

This test is similar to the **READ STATUS** test, except that it checks the priority interrupt IC U22. Momentarily grounding the inputs to U22 should produce the proper interrupt levels. The CRT indicates which pin is to be grounded for each interrupt. U22 pin 4 has the highest priority interrupt. Therefore, grounding it may cause a preset or prevent proper instrument operation. If the instrument locks–up, perform an instrument preset or cycle the line power.

## CPU READ/WRITE CYCLE (Forced Diagnostic Test Only)

This diagnostic test is accessible only by closing switch A3S1–A and pressing **PRESET** or by momentarily grounding L PRESET (A3TP46). It is used to facilitate troubleshooting of several write–associated control lines. The free run test is always in the read mode and therefore does not exercise any control lines associated with write commands. This test should be run if other diagnostic tests are inconclusive. It is most useful when error codes 14 through 10 have been generated. Error code 15 may prevent access to this test.

Typical waveforms are shown in Figure 8–12. These waveforms were taken with the oscilloscope triggered from the negative slope of the CONTROL 2 output instead of the usual CONTROL 1 output.

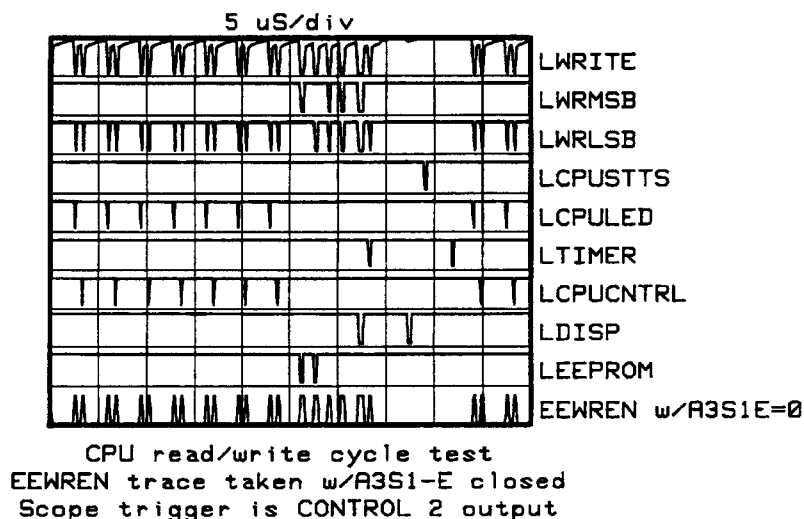


Figure 8–12. CPU Read/Write Cycle

## OTHER TESTS

### WARNING

Danger of explosion if battery is incorrectly replaced. Replace only with the same or equivalent type recommended. Discard used batteries according to manufacturer's instructions.

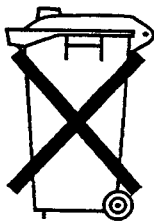
Battery BT1 is a lithium manganese dioxide battery with a nominal voltage of 2.8 V. Check the battery voltage between test points VBAT+ and VBAT- with line power to the instrument turned off. The voltage at TP3 (VBAT) should be about 3 V. Also check the voltage drop across R8 (typically about 1 mV at room temperature). If the voltage across R8 is excessive (>4mV), one of the RAM ICs may be defective. If at any time, the battery voltage drops to a level that causes loss of RAM data, a message will be displayed on the LCD during the next power-up sequence. If the battery is in need of replacement, remember that even after replacement, the next power-up sequence will still show a battery failure message. This will disappear on subsequent power-up cycles. It is recommended that the battery (BT1) be referred to qualified personnel for replacement. Refer to the front section of this manual for a list of sales and service offices.

## LITHIUM BATTERY DISPOSAL

### WARNING

The Agilent Technologies 8757D contains a lithium manganese dioxide battery. The battery must be recycled or disposed of properly.

If the battery on the CPU board becomes ready for disposal. Dispose of it to your country's requirements. If required, you may return the battery to the nearest Agilent Technologies sales or service office for disposal. Refer to the front section of this manual for a list of sales and service offices.



**DO NOT THROW BATTERIES AWAY BUT  
COLLECT AS SMALL CHEMICAL WASTE.**

sk780a

# A3 Troubleshooting

## BASIC CHECKS

Check the +5 V power supply at TP3 (+5V). If the appropriate voltage is not present, refer to A12 power supply “Troubleshooting.”

Check for a 10 MHz clock signal at TP49 (L10MHz). For troubleshooting details see “10 MHz Clock Check”.

Confirm that L MPRESET (U12 pin 8) and L HALT (U12 pin 10) go low when the front panel **PRESET** key is pressed and return high after it is released. In some cases the CPU will prevent **PRESET** from functioning. In those instances perform a *hardwire* PRESET by momentarily grounding TP46 (L PRST).

Check that the free run jumper U11 is in place.

**NOTE:** Improper, intermittent, or erratic operation of the analyzer, where no error code is generated, can indicate a problem in the I/O timing or address decoding portion of the A3 CPU assembly. See “Address Decoders Check” and “I/O Timing Check”.

## SELF-TESTS

During self-test, the majority of A3 CPU failures are detected and cause an error code to be displayed on the A3 board's error code LEDs. Self-test is performed when the instrument is turned on, or **PRESET** is pressed, or A3TP46 (L PRST) is momentarily grounded. During self-test all eight error code LEDs (A3DS1–2) and the HALT LED (A3DS3) should light briefly and then go out. If any of the LEDs do not extinguish, the lit ones indicate an error code in 8–4–2–1 binary (viewed from the component side, left to right). The left hand LEDs indicate a primary error code and this pattern is repeated on the front panel, if possible. The four LEDs on the right indicate a sub error code which gives more specific error analysis. The sub error code is bit specific; each lit LED represents a particular failure. For example: a sub error code of 0001 indicates a specific failure; a sub error code of 0010 indicates a different failure; a sub error code of 0011 indicates the combination of the two failures. Sub error code examples will show examples such as XX1X, where X represents a don't care state and 1 indicates the specific LED that is lit, representing a specific failure.

Primary error codes 15 through 13 indicate problems on the A3 CPU assembly. Error codes 11 and 2 may indicate problems on the A3 CPU board itself or elsewhere in the instrument.

**NOTE:** Error code information indicates that a specific circuit (or device) has failed. Check the surrounding circuits required to exercise the indicated circuit or device. Test the address decoder using the free run test and signature analysis (described later).

Self-tests are performed in descending order. Therefore, self-tests that pass confirm that certain circuits (especially data and address buses) are functioning properly. Use this information to avoid troubleshooting working circuits.

## PRIMARY ERROR CODES

### 1111(Error Code 15) or Unstable or Flashing display: Microprocessor Kernel Failure

**NOTE:** Do not confuse this with a steady, simultaneous, 1.5 Hz flashing rate of all front panel LEDs. The 1.5 flashing display indicates a front panel overload condition and is easily distinguished from a real error code 15 by the fact that the A3 LEDs will not be lit and otherwise normal operation. Refer to the A1/A2 front panel description.

**NOTE:** References to signature analysis in this section should be ignored. The signature multimeter (5005A/B) is no longer available. Troubleshooting can be accomplished without signature analysis.

Error code 15 is probably the most difficult to troubleshoot as it has many possible causes. The microprocessor is unable to perform one of its first instructions: decrement the primary error code to 14. The microprocessor is non-functional and will not respond to any normal stimulus. You must troubleshoot this condition in the following sequence. Perform checks 2 through 5 with the A3 board in free run mode. If you need instructions to perform free run mode, see "Free Run Mode" at the back of this sub-chapter.

1. Check the 10 MHz clock.
2. Check the address lines.
3. Check the address decoders.
4. Check the I/O timing.
5. Check the data lines (perform signature analysis on ROM A).

**10 MHz Clock Check.** This is the first in a series of five procedures. Using an oscilloscope and a 10:1 probe, check for a 10 MHz output from U25B at TP49 (L10MHz). If it is not present, check for a 10 MHz signal at U15 pin 14. If this is not present, check for a 20 MHz signal at U14 pin 8. Also look for 10 MHz at the CPU (U9 pin 15), and at U42 pin 8. All of the signals except LMOD10MHz should be clean TTL square waves, although they may be somewhat distorted by the oscilloscope probe. LMOD10MHz should have a 25% duty cycle.

**Address Lines Check.** This is the second in a series of five procedures. Perform the "10MHz Clock Check" before doing this procedure. You must be in free run mode to perform this procedure. (See "Free Run Mode").

Check all 20 address lines at TP42 through TP23 with an oscilloscope or frequency counter. A1 at TP42 should be a 1.25 MHz square wave. The A2 frequency at TP41 should be one half the frequency of A1. A3 at TP40 should be one half A2, and so on to A20 at TP23 with a frequency of 2.3842 Hz. To confirm the integrity of the address line traces, refer to the "A3 Central Processing Unit (CPU) Schematic Diagram" and check for the appropriate signal at every IC connected to each address line.

Alternatively, check each address line at every IC with a signature analyzer. Set up for signature analysis as follows:



Connections: CPU in free run mode (jumper U18 removed) Signature analyzer mode: NORM Normal TTL levels			
Test Lead	Setting	Test Point	Mnemonic
Clock	Falling Edge	TP48	ASTRB
Start	Rising Edge	TP42	A1
Stop	Falling Edge	TP23	A20
Ground	—	TP4	GND
The characteristic signature for +5 V (TP3) is: 7U39.			

Verify the signatures shown in Table 8–8 at all available locations on the board.

*Table 8–8. Address Signatures*

A1: 55H1	A6: 34P0	A11: FAF6	A16: F3U8
A2: 334U	A7: 0U52	A12: 3HPH	A17: 55H1
A3: 0U16	A8: 48C6	A13: U1U8	A18: 334U
A4: 00UP	A9: HAP7	A14: FA75	A19: 0U16
A5: UUUU	A10: 85U4	A15: C5F0	A20: 00UP

If any address lines are bad and there are no shorts or opens, suspect the CPU U9.

**Address Decoders Check.** This is the third in a series of five procedures. Perform the “10MHz Clock Check” and “Address Lines Check” before doing this procedure. You must be in free run mode to perform this procedure. (See “Free Run Mode”).

The address decoders use A11 through A20 and the LAS, RLW, lines to decode the control lines via PALs U31 and U32. These decoders are most easily checked in the free run mode using signature analysis. Set up for signature analysis as follows:

Conditions: CPU in free run mode (jumper U18 removed) Signature analyzer mode: NORM Normal TTL levels			
Connections:			
Test Lead	Setting	Test Point	Mnemonic
Clock	Falling Edge	TP48	ASTRB
Start	Rising Edge	TP42	A1
Stop	Falling Edge	TP23	A20
Ground	—	TP4	GND
The characteristic signature for +5 V (TP3) is: 7U39.			

First check each signature at the address decoder PAL. Then check each signature at every IC that the control line services (Table 8–9). Remember that this test only exercises non–write associated lines. Write associated lines such as LCPULED and EEWREN must be tested using the CPU status loop test described previously.

**Table 8–9. Control Signatures**

Line	Signature	Line	Signature	Line	Signature
LDTTST	F340	LEEPROM	7F3P	LDISP	P496
LIOS	P25F	LRAMB	UA76	CPUSTTS	C3H0
LDTACK0	00UP	LRAMA	U668	LTIMER	714P
LDTACK1	CF87	LROMB	4U42	LIO	79U3
LROM	OUP7	LROMA	3U9F	LLDS,LUDS	0000

These lines should be at a constant logic 0: EEWREN, FC0.

These lines should be at a constant logic 1: FC1, FC2, LVPA, IPL0–2, LCPULED, RLW, LWRMSB, LWRLSB, LINTACK, LINT1DTK.

**I/O Timing Check.** This is the fourth in a series of five procedures. Perform “10 MHz Clock Check”, “Address Lines Check”, and “Address Decoders Check” before doing this procedure. You must be in free run mode to perform this procedure.

There are two simple tests to verify the proper operation of this circuitry. The first test uses the signature analyzer. Set up for signature analysis as follows:

Conditions:	CPU in free run mode (jumper U18 removed)		
	Signature analyzer node: NORM		
	Normal TTL levels		
Connections:			
Test Lead	Setting	Test Point	Mnemonic
Clock	Falling Edge	TP48	ASTRB
Start	Rising Edge	TP42	A1
Stop	Falling Edge	TP23	A20
Ground	—	TP4	GND
The characteristic signature for +5 V (TP3) is: 7U39.			

Look for the following signatures:

1. At LIOS (TP47): P25F
2. At LDTTST (TP5): F340

To perform the second test (while still in free run mode), remove the CRT interface W8 and measure the period of A20 at TP23. It should be  $419.430 \pm 0.002$  ms.

**NOTE:** The time periods given are accurate to within  $\pm 0.002$  ms.

Jumper TP5 (LDTTST) to TP6 (LDT). The period should now be 1.2386 seconds. (If W8 is not removed, the period will be about 780 ms.) Replace W8.

If either one of these tests fails, temporarily jumper TP44 (LW22) to TP6 (LDT) and compare the outputs from U42 and U43 with those shown in Figure 8–13. Check all gates for proper operation, and check the address decoder signatures above.

**Data Lines Check.** This is the last in a series of five procedures. Perform "10 MHz Clock Check", "Address Lines Check", "Address Decoders Check", and "I/O Timing Check" before doing this procedure. You must be in free run mode to perform this procedure.

The analyzer contains only two EPROMs. Future revisions of firmware may require four EPROMs. Four EPROMs are documented, since that case is more complex than with two.

Check the data lines by reading the signatures of the contents of ROM A (U7, U29) and ROM B (U8, U30) using the following two signature analysis procedures. Interpret the results using the information following the signature analysis procedures.

Configure the signature analyzer as follows and check the ROM A (U7 and U29), data lines:

Conditions:			
CPU in free run mode (jumper U18 removed)			
Signature analyzer in QUAL function mode			
Normal TTL levels			
Connections:			
Test Lead	Setting	Test Point	Mnemonic
Clock	Falling Edge	TP48	ASTRB
Start/ Stop	Falling Edge	TP50	LROM
	Rising Edge	—	—
Qual	Low State	TP25	A18
Ground	—	TP4	GND
The characteristic signature for +5 V (TP3) is: 0003.			

**NOTE:** Each time the analyzer firmware is updated, the ROM signatures are changed. These changes are documented in a *Firmware Update* provided with the *Manual Changes Supplement*. (See "Instruments Covered By Manual" in the operating manual for information regarding *Manual Changes Supplements*.) Firmware update information is also supplied with each new set of firmware purchased. Refer to the *Firmware Update* for ROM A signatures. Be sure to use the signatures for the correct firmware revision number.

Incorrect signatures at D15 through D8 indicate a fault in U29. Incorrect signatures at D7 through D0 indicate a failure in U7.

To set up for signature analysis to check ROM B data lines, use the same conditions and connections used for the ROM A check with the exception of the Qual mode setting. This should be set to the high position in order to read ROM B. The characteristic signature for +5 V remains 0003.

**NOTE:** Refer to the *Firmware Update* for ROM B signatures if applicable. Be sure to use the signatures for the correct firmware revision number.

Incorrect signatures at D15 through D8 indicate a fault in U30. Incorrect signatures at D7 through D0 indicate a failure in U8.

Depending on the failure mode, the CPU read/write cycle test may also be useful for troubleshooting. However, in most cases, error code 15 will prevent execution of this cycle. The CPU read/write cycle is described on an earlier page.

An error in both ROMs indicates that both are probably good, and one or more of the data lines is probably open or shorted. However, the error may be the result of another device improperly attempting to place data on the bus at the same time. To determine whether the error is data line or device related, remove the ROM under test and verify that the signatures on all of the ROM A data lines are 755U (the same as for +5 V), and the signatures on all of the ROM B data lines are either 755U or 0000.

An error in just one of the ROMs (ROM A or ROM B) indicates that only that particular ROM is defective. All self-tests are contained in ROM A. When ROM A is good, the self-tests should find any faults in ROM B. However when ROM A is suspect, it is necessary to analyze ROM B to isolate the fault to either ROM A or the data lines.

This completes the series of tests associated with error code 1111 (15). Replace the free run jumper U11. If the board has passed all of the preceding tests and inspections but still does not work, suspect the CPU U9, or U10 or U32.

### ROM Signatures

U7		U29	
Line	Signatures	Line	Signatures
	Rev 5.1		Rev 5.1
D0	A4PP	D8	383F
D1	6H16	D9	C82F
D2	6073	D10	9P18
D3	824P	D11	910H
D4	5597	D12	09HU
D5	C08F	D13	26F8
D6	0571	D14	9760
D7	5656	D15	3P02

## 1110 (Error Code 14) — ROM Checksum

**Sub Error Code 0000 —ROM Checksum Started.** The microprocessor has successfully completed the first instruction (to decrement the primary error code indicators to 14). The CPU has started the checksum test of ROM A but is unable to complete it. This failure usually indicates a fault in ROM A (U7 or U29) since the checksum test instructions reside there.

Perform the ROM A signature analysis test described above to determine which ROM is defective, or simply replace all ROMs with the firmware update kit.

**Sub Error Code XXX1 — ROM A Checksum Failure.** The microprocessor has successfully completed the ROM A checksum test and it has failed. ROM A (U7, U29) is probably defective. Determine which ROM is defective by performing the ROM A signature analysis check in “Data Lines Check” or simply replace all ROMs with the firmware update kit.

**Sub Error code XX1X — ROM B Checksum Failure (if applicable).** The microprocessor has found the checksum of ROM B (U8, U30) to be bad. Address and data lines to ROM A have been verified. Suspect ROM B or address decoding to ROM B. Verify which ROM is bad by performing the ROM B signature analysis test described above, or simply replace all of the ROMs with the firmware update kit.

## 1101 (Error Code 13) —RAM Failure

**Sub Error Code XXX1 —RAM A LSB (U5) or**

**Sub Error Code XX1X —RAM A MSB (U27) or**

**Sub Error Code X1XX —RAM B LSB (U6) or**

**Sub Error Code 1XXX —RAM B MSB (U28).** Error code 13 indicates a failure in the associated RAMs. The data lines have been verified up to ROM A, but the lines could be open between ROM A and the RAM in question. Check for continuity on these lines. Also check the decoded address lines (control lines) and the buffered enable lines. If the address, data, and control lines are good, suspect the indicated RAM.

**Sub Error Code 0000 —RAM Checksum Failure.** The microprocessor has successfully verified the storage ability of all four RAMs. However the checksum generated before performing the test does not match the checksum generated afterwards. Although unlikely, if this error code appears repeatedly, suspect any of the four RAMs or possible intermittent IC connections.

## 1100 (Error Code 12) —Power Supply Failure

This error code indicate a supply failure (or significantly out-of-tolerance) supply. The analyzer is not capable of determining which supply has failed, so no sub error codes are used. Refer to the A12 power supply “Troubleshooting” procedure.

## **1011 (Error Code 11) —Instrument Bus Failure**

**Sub Error Code XXX1 —All Bits Low Failed or**

**Sub Error Code XX1X —All Bits High Failed or**

**Sub Error Code X1XX —Walking 1 Pattern Failed.** The microprocessor has passed most of its self-tests but it cannot write data onto the instrument bus and then read the same data back. (The instrument bus consists of buffered address lines 1 through 8 and buffered data lines 0 through 15.) Under these conditions, the CPU will continuously repeat the instrument bus cycle test until it passes. Since the data is written to, and read from a temporary storage device on the A6 HP-IB board, this error code may simply indicate that the A6 board is not in place.

If the A6 board is in place, refer to A6 HP-IB assembly "Troubleshooting" for more information and a complete description of the sub error codes.

## **1010 —0011 (Error Codes 10–3) —Display Interface Failure**

The microprocessor has successfully verified the instrument bus but it has determined that the display interface board is not functioning properly or the display interface cable is missing. Refer to the A14 display interface "Troubleshooting" procedure for a complete description of each test and the meaning of each sub error code.

## **0010 (Error Code 2) —Interrupt Failure**

**Sub Error Code XXX1 —Unexpected Interrupt Detected or**

**Sub Error Code XX1X —No Interrupt Detected or**

**Sub Error Code X1XX —GSP Interrupt Failed.** The microprocessor has passed all critical CPU self tests but has received either an unexpected interrupt or no interrupt when one was expected. During operation, this would prevent the instrument from functioning properly. This kind of interrupt can be experienced on several levels. Fortunately, since the display has been digitally verified, the CPU should indicate on the CRT the level where the interrupt was unexpectedly detected.

Interrupts are generated by U22, which receives its input from several sources. The highest level interrupt, 1, is generated through an L SRQPF signal (power failure warning) at U22 pin 4. The lowest level working interrupt, C (Hex), is generated by the self-test interrupt line, LLEV1INT, U21 pin 2. The interrupts are listed in Table 8–10.

*Table 8–10. Interrupt Levels*

Interrupt Level	U22 Pin	Mnemonic	Interrupt Level	U21 Pin	Mnemonic
1	4	L SRQPF	7	1	LT0INT
2	3	L STTS INT	8	11	LT1INT
3	2	L DRINT	9	6	LT2INT
4	1	L SRQA	A	4	LDISPINT
5	13	L SRQB	B	3	LSUPPLYFL
6	12	L SRQ FP	C	2	LLLEV1INT

If error code 2 appears, first verify that the U22 or U21 input pin corresponding to the interrupt level displayed on the CRT is at a steady logic high. If the input is not high, trace the faulty line back to its source. If all of the inputs to U22 (pins 1 through 4 and 10 through 13) are high, suspect U22 or its three output lines (pins 6, 7, and 9) which also should be high.

Note that grounding TP45 (INT) will prevent all interrupts from occurring (all outputs high).

### **0001 (Error Code 1) —Instrument Verify Failures**

The CPU has passed all of its internal self–tests. Now it tests several other circuits. These additional tests are essentially the same as those done during the instrument verification routine accessible from the service menu. The display has been digitally verified. Thus, as a troubleshooting aid, the CPU attempts to display all subsequent test results on the CRT. However the CPU cannot confirm that the CRT is actually displaying the information it is receiving. For example, the CRT may lack high voltage, or the intensity may be turned down too far for the trace to be visible. If error code 1 is indicated by the LEDs but nothing is visible on the CRT, see A15 Display “Troubleshooting” for further information. Then see “Instrument Verify”, at the beginning of this service Chapter, for a more detailed description of the tests performed and additional references for troubleshooting information.

**Unexpected Key Pressed.** This is part of error code 1. The analyzer has passed all the self–tests and has determined that a front panel key is either stuck or pressed. Because this condition locks up the front panel, it must be corrected. When the CPU detects a pressed or stuck front panel key, it immediately displays the name of that key on the CRT. In this case, troubleshoot the circuits related to the indicated key.

**Battery Test Failed.** This is part of error code 1. This message will appear if the battery voltage has dropped to the point where the contents of RAM may have been lost. This test is only performed upon power–up. If this test should fail, check the 2.8 V battery on the A3 board. If the voltage is below 2.4 volts, replace it. After replacement, the battery test will again fail on the very next power–up sequence, but future cycles should pass.

**Configuration Error 1, 2, or 3.** This is part of error code 1. This message will appear if the CPU detects a hardware configuration incompatibility and does not generally indicate a failure. Contact your local HP sales or service office for more information.

### **0000 (Error Code 0)**

This code indicates that the instrument has passed all of the self–tests.

## FREE RUN MODE

Perform the “Basic Checks” before this free run test. The free run test is used to verify and troubleshoot the microprocessor kernel and related circuitry. It is used primarily for microprocessor failures when the self-test yields error code 15. It is also useful for verifying the address decoder lines when ROM, RAM or other errors are indicated by error codes 14 or 13.

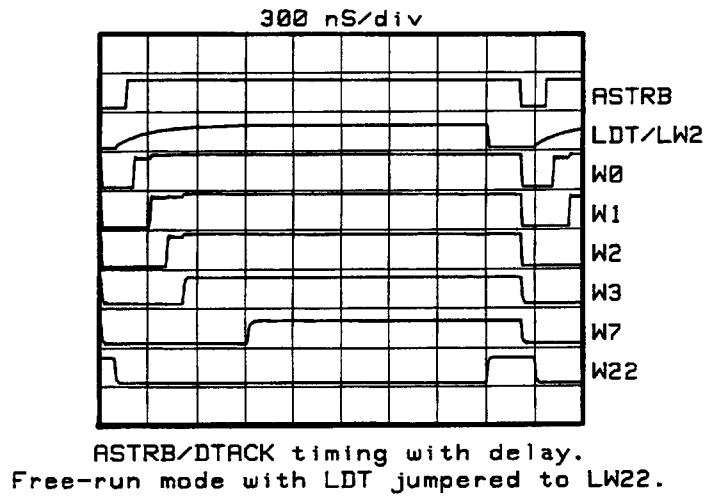
The free run test generates fixed data at the data inputs of microprocessor U9, and forces U9 into a read mode. U9 executes the instruction contained in the fixed data and then increments the address to seek a new instruction. The actual instruction contained in the fixed data is irrelevant. The goal is to exercise all of the address lines, access every address, and verify this performance using signature analysis while the cycle repeats. Since all addresses are accessed in this cycle, address decoding is also completely exercised and can be verified with signal analysis. I/O timing is also exercised (because each cycle requires an ASTRB/L DTACK response) and can be verified with an oscilloscope.

To perform the free run test, carefully remove the jumper pack U18 from its socket on the A3 CPU assembly. Cycle the power switch to reset the microprocessor. Check that DS3 (HALT) and DS1–2 (error code LEDs) turn on when power is first applied. The L HALT LED should extinguish after about 1/2 second. If DS3 does not go out, check the power on/preset circuitry. Check that the L MPRESET and L HALT lines return to TTL high after 1/2 second. If L MPRESET stays low, the microprocessor U9 may be holding it down.

Check ASTRB at TP48 (ASTRB). Verify that the waveform has a period of 400 ns with a duty cycle of 60%. If the waveform is not correct, the free run test probably is not running. Perform the basic checks described above. At the microprocessor, check the data lines that are affected by the free run jumper U18: D0, D8 and D15 should be low; D12, D13 and D14 should be high; otherwise, troubleshoot U11, U12 and U20.

Jumper TP44 (LW22) to TP8 (LDT) and check for the waveforms shown in Figure 8–13, ASTRB/L DTACK Timing with Delay.





*Figure 8-13. ASTRB/DTACK*

*Table 8-11. A3 CPU Address Decoder Lines*

Mnemonic	Address Hexadecimal	Destination	Description
L ROM A	000000-03FFFE	U7, U29	Enables Read from ROM A
L ROM B	040000-07FFFE	U8, U30	Enables Read from ROM B
RAM A	080000-0BFFFE	U5, U27	Enables RAM A
RAM B	090000-09FFFE	U6, U28	Enables RAM B
LCPUSTTS	1FC000	U3	Enables Read of Stats
LCPULED	1FC000	U1	Enables Write to Error Code LEDs
L EEPROM	0C000 0FFFFE	U4, U26	Enables EEPROM
LCPUCNTRL	1FC800	U39	Enables timing interrupts and other outputs

Table 8-12. A3 Pin-Outs (1 of 2)

PIN	SIGNAL	I/O	SOURCE/ DESTINATION	FUNCTION BLOCK
1 41	+5V DIG +5V DIG	IN IN	A11J6-8,9 A11J6-8,9	M M
2 42	GND DIG GND DIG	IN IN	A11J6-6,7 A11J6-6,7	M M
3 43	ID15 LPFW	I/O IN	A4P2-3, A6P1-43, A11J7-4 A11J6-5	L M
4 44	ID14 GND DIG	I/O	A4P2-4, A6P1-44, A11J7-3 A4P1-22 NOT USED	L
5 45	ID13 NC	I/O	A4P2-5, A6P1-45, A11J7-6	L
6 46	ID12 SPLYFAIL	I/O IN	A4P2-6, A6P1-46, A11J7-5 A11J6-3	L C
7 47	ID11 NC	I/O	A4P2-7, A6P1-47, A11J7-8	L
8 48	ID10 NC	I/O	A4P2-8, A6P1-48, A11J7-7	L
9 49	ID9 NC	I/O	A4P2-9, A6P1-49, A11J7-10	L
10 50	ID8 NC	I/O	A4P2-10, A6P1-50, A11J7-9	L
11 51	ID7 NC	I/O	A4P2-11, A6P1-51, A11J1-11, A11J7-14	L
12 52	ID6 NC	I/O	A4P2-12, A6P1-52, A11J1-12, A11J7-13	L
13 53	ID5 NC	I/O	A4P2-13, A6P1-53, A11J1-9, A11J7-16	L
14 54	ID4 L DISP INT	I/O IN	A4P2-14, A6P1-54, A11J1-10, A11J7-15	L C
15 55	ID3 L DR INT	I/O IN	A4P2-15, A6P1-55, A11J1-7, A11J7-18	L C
16 56	ID2 L STTS INT	I/O IN	A4P2-16, A6P1-56, A11J1-8, A11J7-17	L C
17 57	ID1 NC	I/O	A4P2-17, A6P1-57, A11J1-5, A11J7-20	L
18 58	ID0 NC	I/O	A4P2-81, A6P1-58, A11J1-6, A11J7-19	L
19 59	L SRQ FP NC	IN	A11J1-27	C
20 60	IA6 IA	OUT OUT	A4P2-60, A6P1-60, A11J1-16 A4P2-19, A4P2-59, A6P1-59,	L L
21 61	IA5 IA8	OUT OUT	A4P2-21, A6P1-61, A11J1-15 A4P2-61, A6P1-20, A11J1-14	L L
22 62	IA4 NC	OUT	A4P2-22, A6P1-62, A11J1-18	L
23 63	IA3 NC	OUT	A4P2-23, A6P1-63, A11J1-17, A11J7-24	L
24 64	IA3 NC	OUT	A4P2-24, A6P1-64, A11J1-20, A11J7-23	L

**Table 8-12. A3 Pin-Outs (2 of 2)**

PIN	SIGNAL	I/O	SOURCE/ DESTINATION	FUNCTION BLOCK
25 65	IA1 NC	OUT	P2-25, A6P1-65, A11J1-19, A11J7-26	L
26 66	GND DIG SH NC	I/O	A3P1-28	M
27 67	L IOS NC	OUT	A4P2-27, A6P1-67, A11J1-21	L
28 68	GND DIG SH NC	I/O	A3P1-30	M
29 69	L WRITE NC	OUT	A4P2-29, A6P1-69, A11J7-25	L
30 70	GND DIG SH L SRQA	I/O IN	A3P1-34 A6P1-72	M C
31 71	L RESET NC	OUT	A4P2-31, A6P1-71, A11J1-23, A11J7-32	L
32 72	CAL MOD EN NC	OUT	A5P1-31 NOT USED	
33 73	L SRQB L XACK	IN IN	A6P1-73 A11J7-29	C F
34 74	GND DIG SH L IPRESET	I/O IN	J8-11 A11J1-25	M B
35 75	5MHZ L 27K MOD DR	OUT OUT	A6P1-75 A5P1-32	A K
36 76	NC CAL OSC EN	OUT	A5P1-14 NOT USED	
37 77	NC NC			
38 78	L DISP NC	OUT	A11J7-30	L
39 79	NC CNTRL 1	OUT	A1J8-51	K
40 80	CNTRL2 GND DIG SH	OUT I/O	A11J8-53	K M

**Replaceable Parts List for A3 Assembly (1 of 2)**

Reference Designation	HP Part Number	Qty	Description	Mfr Code	Mfr Part Number
A3 (SEE NOTE)	08757-60115	1	BD ASSY-CPU - 8757D	28480	08757-60120
A3BT1	1420-0394	1	BATTERY 3V 1A-HR LI MANGANESE DIOXIDE	08709	CR2477-1HF
A3C1-C2	0160-4084	1	CAP-FXD 0.1uF ±20% 50 V CER X7R	02010	SR215C104MAAH
A3C3	0180-3833	1	CAP-FXD 22uF ±10% 10 V TA	04200	299D226X9010CB1
A3C4-C5	0160-4084	1	CAP-FXD 0.1uF ±20% 50 V CER X7R	02010	SR215C104MAAH
A3C6	0180-3833	1	CAP-FXD 22uF ±10% 10 V TA	04200	299D226X9010CB1
A3C7 - C21	0160-4084	15	CAP-FXD 0.1uF ±20% 50 V CER X7R	02010	SR215C104MAAH
A3C22	0180-3833	1	CAP-FXD 22uF ±10% 10 V TA	04200	299D226X9010CB1
A3C23	0160-4084	1	CAP-FXD 0.1uF ±20% 50 V CER X7R	02010	SR215C104MAAH
A3C24	0180-3771	1	CAP-FXD 1uF ±10% 35 V TA	04200	299D105X9035AB1
A3C25	0180-3845	1	CAP-FXD 4.7uF ±10% 35 V TA	04200	299D475X9035CB1
A3CR1	1901-0033	1	DIODE-GEN PRP 180V 200MA DO-35	03406	
A3DS1-DS2	1990-0652	1	LED-LAMP ARRAY LUM-INT=200UCD IF=5MA-MAX	01542	HLMP-6620 SELECTED
A3DS3	1990-0685	1	LED-LAMP LUM-INT=200UCD	01542	HLMP-6620
A3L1	08503-80001	1	COIL - TOROID		
A3MP2	4040-0751	2	EXTR-PC BD ORN POLYC .062-IN-BD-THKNS	10456	
A3MP3	1480-0073	2	PIN-ROLL .062-IN-DIA .25-IN-LG BE-CU	04559	99-012-062-0250
A3MP4	9320-5885		LBL-LNE-PTR; 18-MM-WD X 2.7-MM-LG	03211	
A3P1	1251-7907	1	CONN-POST TYPE .100-PIN-SPOG 80-CONT	01380	534204-8
A3R1	0757-0280	1	RESISTOR 1K ±1% .125W TF TC=0±100	05524	
A3R2	0757-0442	1	RESISTOR 10K ±1% .125W TF TC=0±100	05524	
A3R3-R5	0698-3155	1	RESISTOR 4.64K ±1% .125W TF TC=0±100	05524	
A3R6	0757-0465	1	RESISTOR 100K ±1% .125W TF TC=0±100	05524	
A3R7-R8	0757-0280	1	RESISTOR 1K ±1% .125W TF TC=0±100	05524	
A3R9	0757-0419	1	RESISTOR 681 ±1% .125W TF TC=0±100	05524	
A3R10	0757-0280	1	RESISTOR 1K ±1% .125W TF TC=0±100	05524	
A3S1	3101-2340	1	SWITCH-DIP RKR 5-1A 0.05A 30VDC	04990	76PSB05S
A3TP1 - TP6	1460-2201	6	SPRING RADIAL TEST POINT		
A3TP7 - TP22	1251-6799		CONN-POST TYPE .100-PIN-SPCG 36-CONT	02946	68001-636
A3TP43 - TP50	1460-2201	1	SPRING RADIAL TEST POINT		
A3U1	1820-3318	1	IC FF TTL/ALS D-TYPE POS-EDGE-TRIG COM	01698	SN74ALS273N
A3U2	1810-0279	1	NETWORK-RES 10-SIP 4.7K OHM X 9	05524	MSP10A01-472G
A3U3	1820-3145	1	IC DRVR TTL/ALS BUS OCTL	01698	SN74ALS244BN
A3U4	1818-4227	1	IC 16K EEPROM 200-NS NMOS	10572	X2816CP-20
A3U5-U6	1818-4228	1	IC 256K SRAM 120-NS CMOS	06347	HM62256ALP-12SL
A3U7 - U8	08757-60129	1	EEPROM's NOT SEPARATELY REPLACEABLE. ORDER KIT, CONTAINS 1 SET EPROMS HP 8757D ONLY		
A3U9	1820-4570	1	IC-16-BIT,10MHZ,PLSTC.MPU,32-B DATA BUS	02037	MC68000P10
A3U10	08757-80057	1	PAL-INTERRUPT		
A3U11	1810-0371	1	NETWORK-RES 8-SIP 100.0K OHM X 7	02483	750-81
A3U12	1820-3376	1	IC INV TTL/ALS HEX	01698	SN74ALS05AN
A3U13	1826-0180	1	IC TIMER GP 8 PIN DIP-P	02910	NE555N
A3U14	1813-0185	1	CLOCK-OSCILLATOR-XTAL 20-MHZ 0.05%	01417	HS-109
A3U15	1820-3645	1	IC CNTR TTL/F DECD SYNCHRO POS-EDGE-TRIG	03406	74F160APC
A3U16-U17	1820-5497	1	IC-NONVOLATILE MEMORY CONTROLLER	12186	DS1210
A3U18	1258-0177	1	SHUNT-PROGRAMMABLE 8 DBL PIN SETS; .800	05518	8136-475G8
A3U19	1820-3145	1	IC DRVR TTL/ALS BUS OCTL	01698	SN74ALS244BN
A3U20	1810-0279	1	NETWORK-RES 10-SIP 4.7K OHM X 9	05524	MSP10A01-472G
A3U21	1820-2773	1	IC GATE TTL/ALS NAND 8-INP	01698	SN74ALS30AN
A3U22	1820-1851	1	IC ENCDR TTL/LS PRIORITY 8-TO-3-LINE	01698	SN74LS148N
A3U23	1810-0279	1	NETWORK-RES 10-SIP 4.7K OHM X 9	05524	MSP10A01-472G
A3U24	1820-3185	1	IC SCHMITT-TRIG CMOS/HC INV HEX	03406	MM74HC14N

**Replaceable Parts List for A3 Assembly (2 of 2)**

Reference Designation	HP Part Number	Qty	Description	Mfr Code	Mfr Part Number
A3U25	1820-2685	1	IC GATE TTL/F NOR QUAD 2-INP	02910	74F02N
A3U26	1818-4227	1	IC 16K EEPROM 200-NS NMOS	10572	X2816CP-20
A3U27-U28	1818-4228	1	IC 256K SRAM 120-NS CMOS	06347	HM62256ALP-12SL
A3U29 - U30 (SEE NOTE)	08757-60191	1	EEPROM's NOT SEPARATELY REPLACEABLE, ORDER KIT, CONTAINS 1 SET EPROMS HP 8757D ONLY		
A3U31	08757-80058	1	PAL - MEM DECODER		
A3U32	08757-80059	1	PAL - IO		
A3U33	1820-2506	1	IC INV TTL/F HEX	02910	74F04N
A3U34-U35	1820-3121	1	IC TRANSCEIVER TTL/ALS BUS OCTL	01698	SN74ALS245AN
A3U36	1820-3093	1	IC-8000-SERIES PROGRAMMABLE TIMER	03811	P8254
A3U37	1820-3318	1	IC FF TTL/ALS D-TYPE POS-EDGE-TRIG COM	01698	SN74ALS273N
A3U38	1820-2656	1	IC GATE TTL/ALS NAND QUAD 2-INP	01698	SN74ALS00AN
A3U39	1820-3318	1	IC FF TTL/ALS D-TYPE POS-EDGE-TRIG COM	01698	SN74ALS273N
A3U40	1820-3376	1	IC INV TTL/ALS HEX	01698	SN74ALS05AN
A3U41	1820-2778	1	IC CNTR TTL/ALS DECD SYNCHRO	01698	SN74ALS162BN
A3U42	1820-3649	1	IC SHF-RGTR TTL/F SYNCHRO SERIAL-IN	02910	74F164N
A3U43	1820-2779	1	IC CNTR TTL/ALS BIN SYNCHRO	01698	SN74ALS163BN
A3X1	1200-0607	1	SOCKET-IC-DIP 16-CONT DIP DIP-SLDR	01380	2-641600-1
A3X2	1200-1326	4	SOCKET-IC-DIP 32-CONT DIP DIP-SLDR	05518	832-AG12D

**NOTE:** The part number for the A3 CPU board includes the EPROM's U29 and U30. Each time the firmware is revised, the part number for the A3 CPU board changes. If a CPU board fails, and the firmware is to remain unchanged, order the current part number for the CPU board as the replacement board. When the replacement board arrives, move the EPROM's from the failed board to the replacement board.

The part number for the 8757D firmware kit with a CRT display is 08757-60129 (most recent revision 6.2). The part number for the 8757D firmware kit with a LCD display is 08757-60191 (revision 7.0).

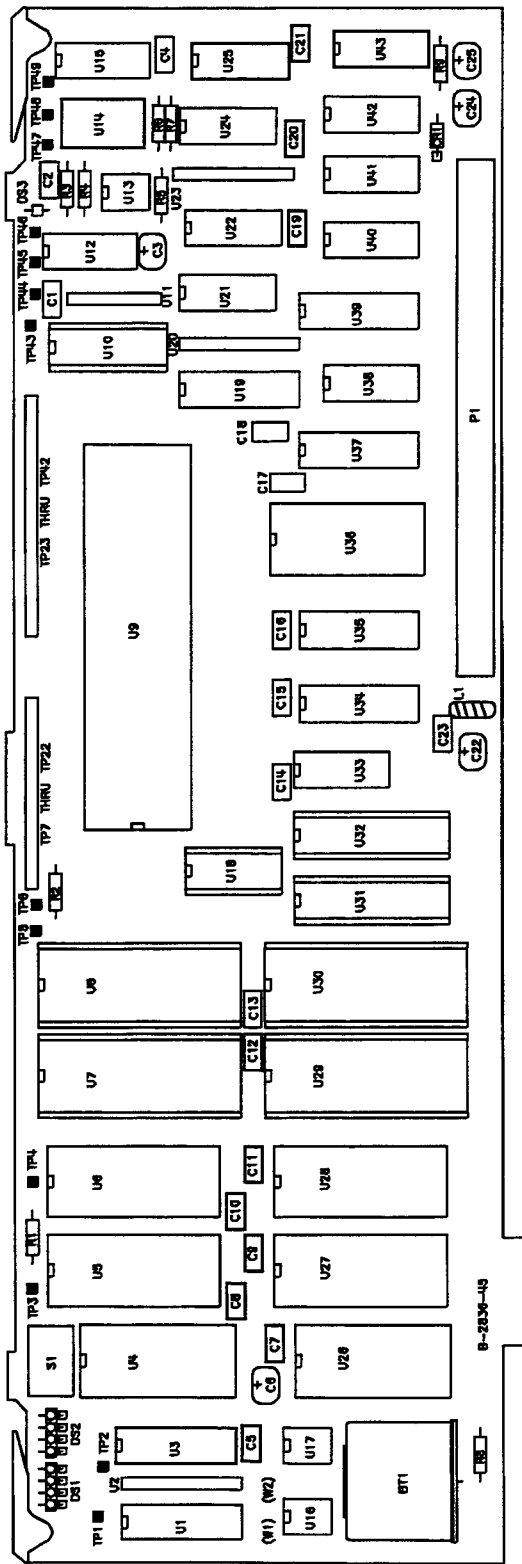
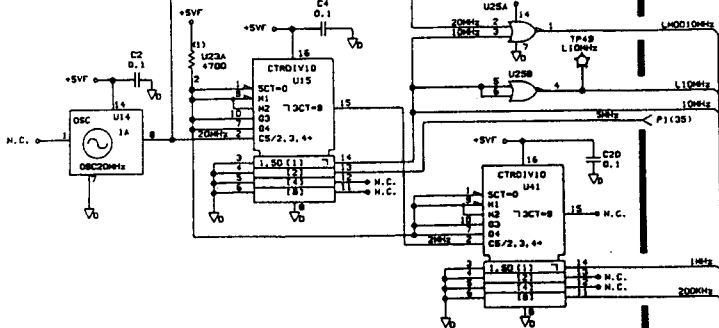
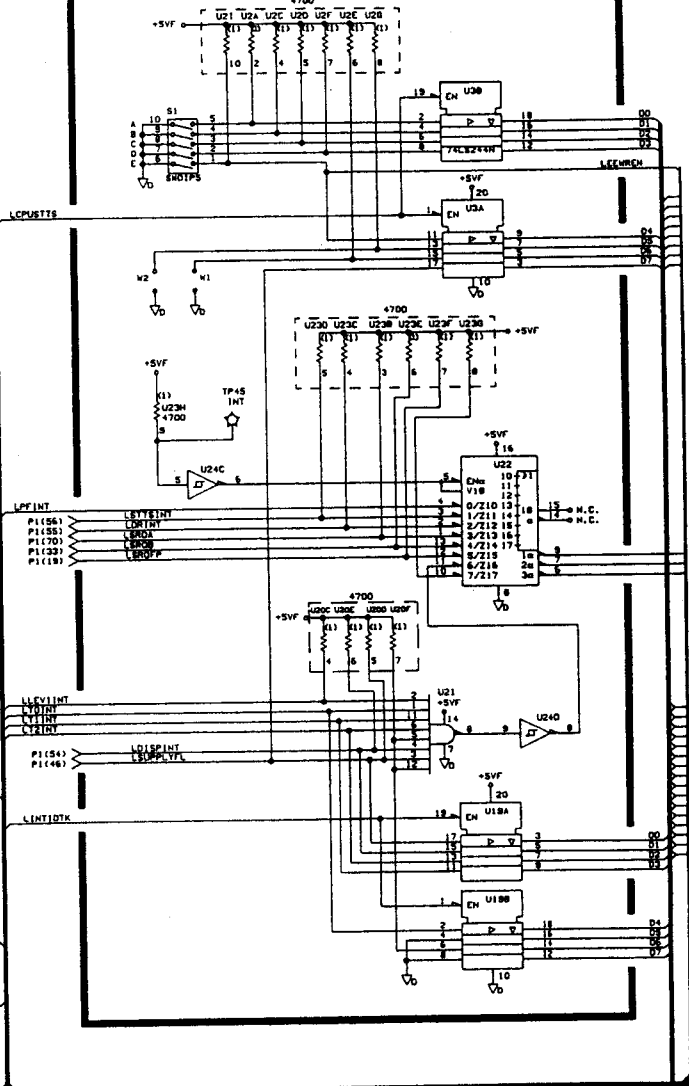


Figure 8-14. A3 Component Locations Diagrams

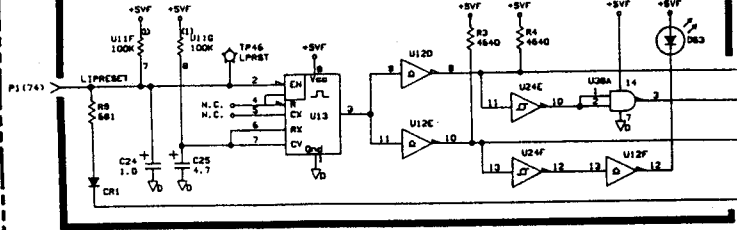
**(A) CLOCK**



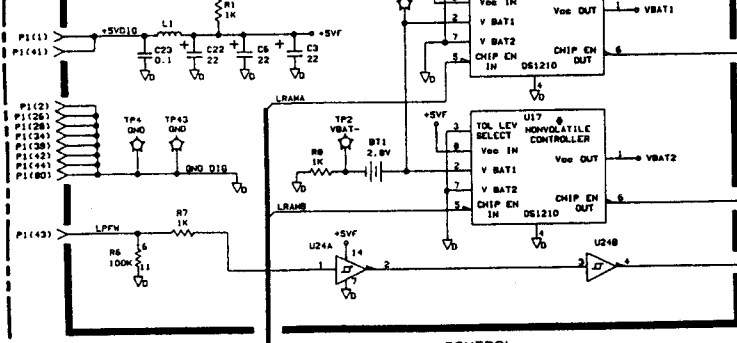
**(C) STATUS/INTERCEPT**

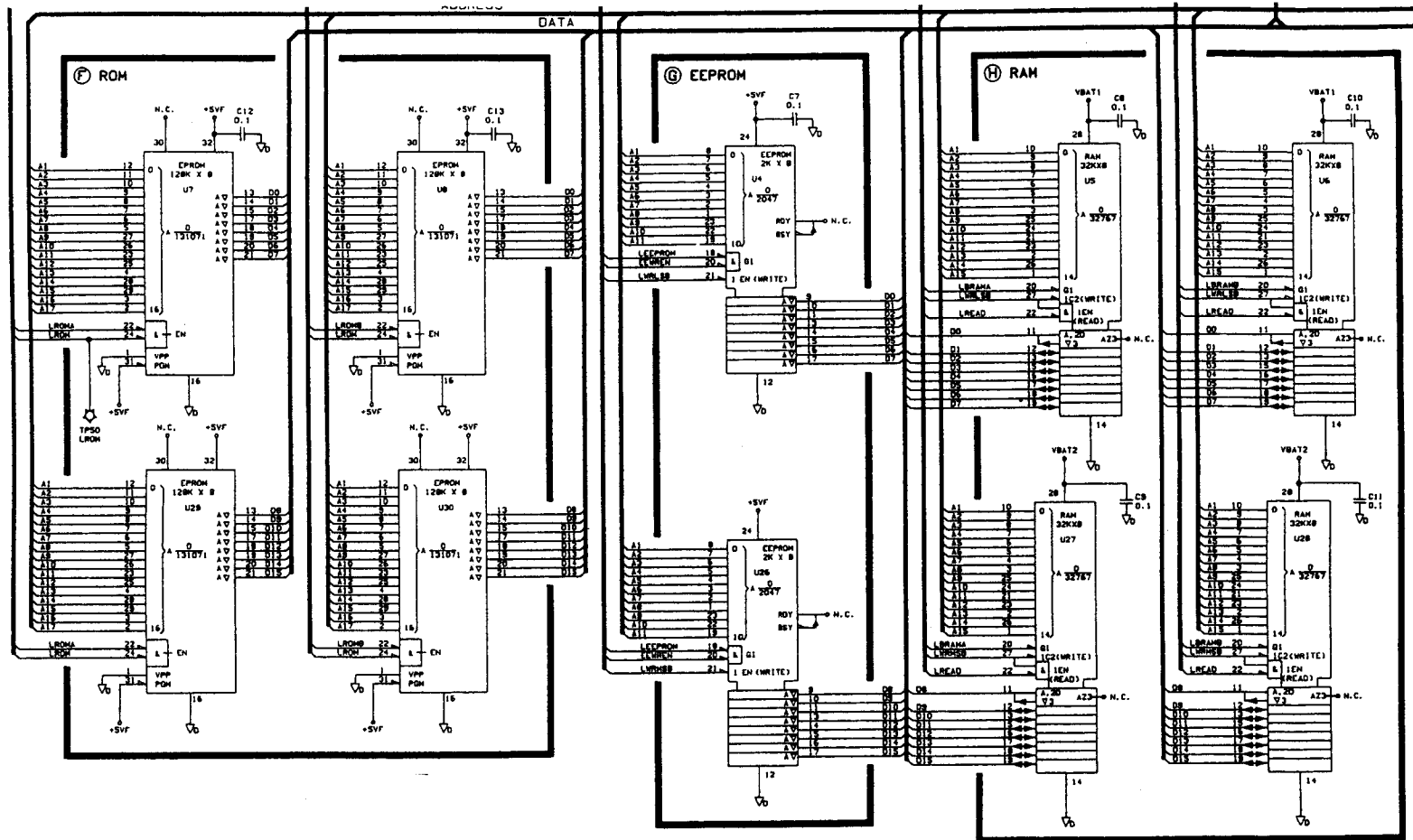


**(B) POWER-ON/PRESET**



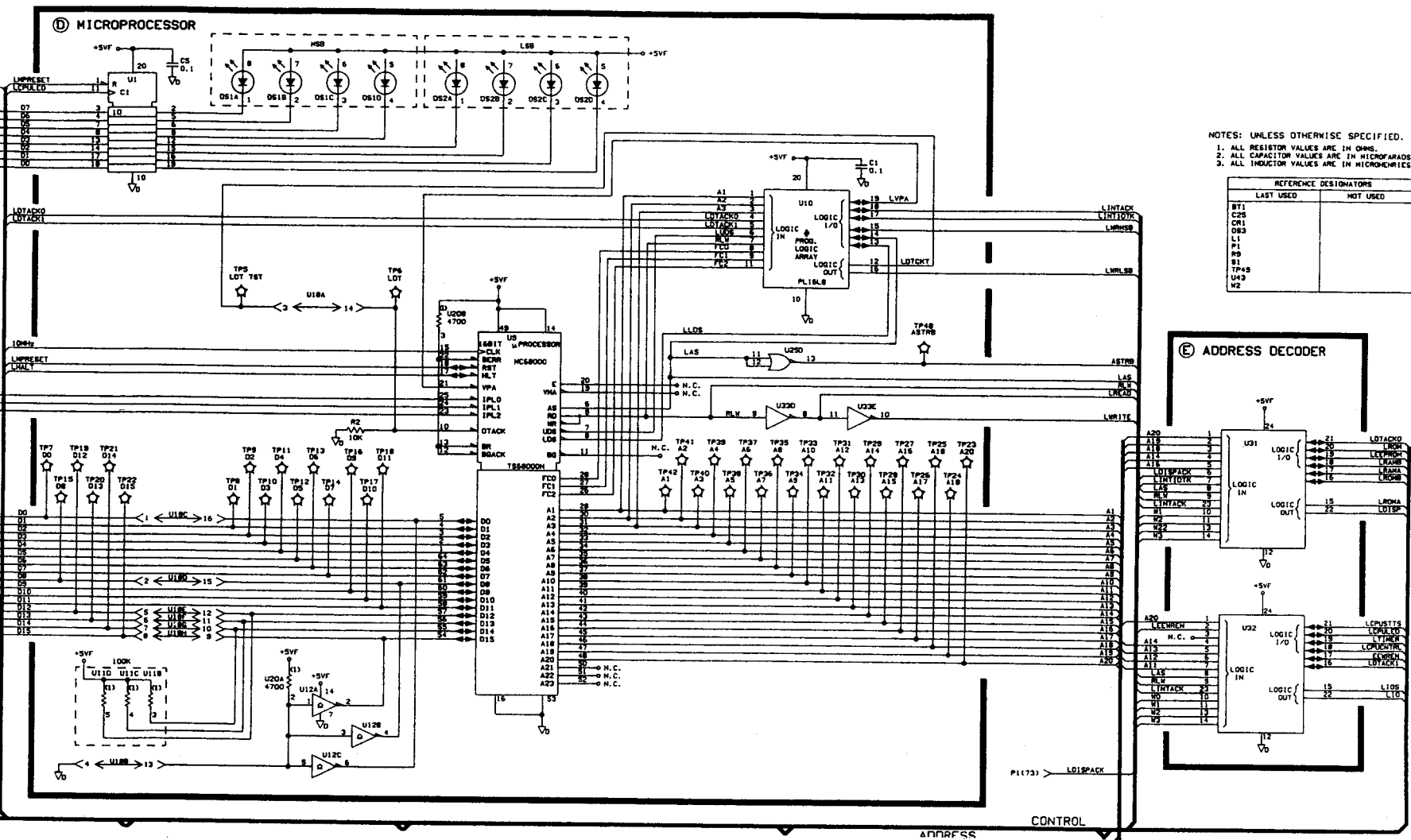
**(D) POWER SUPPLY-FILTERING**

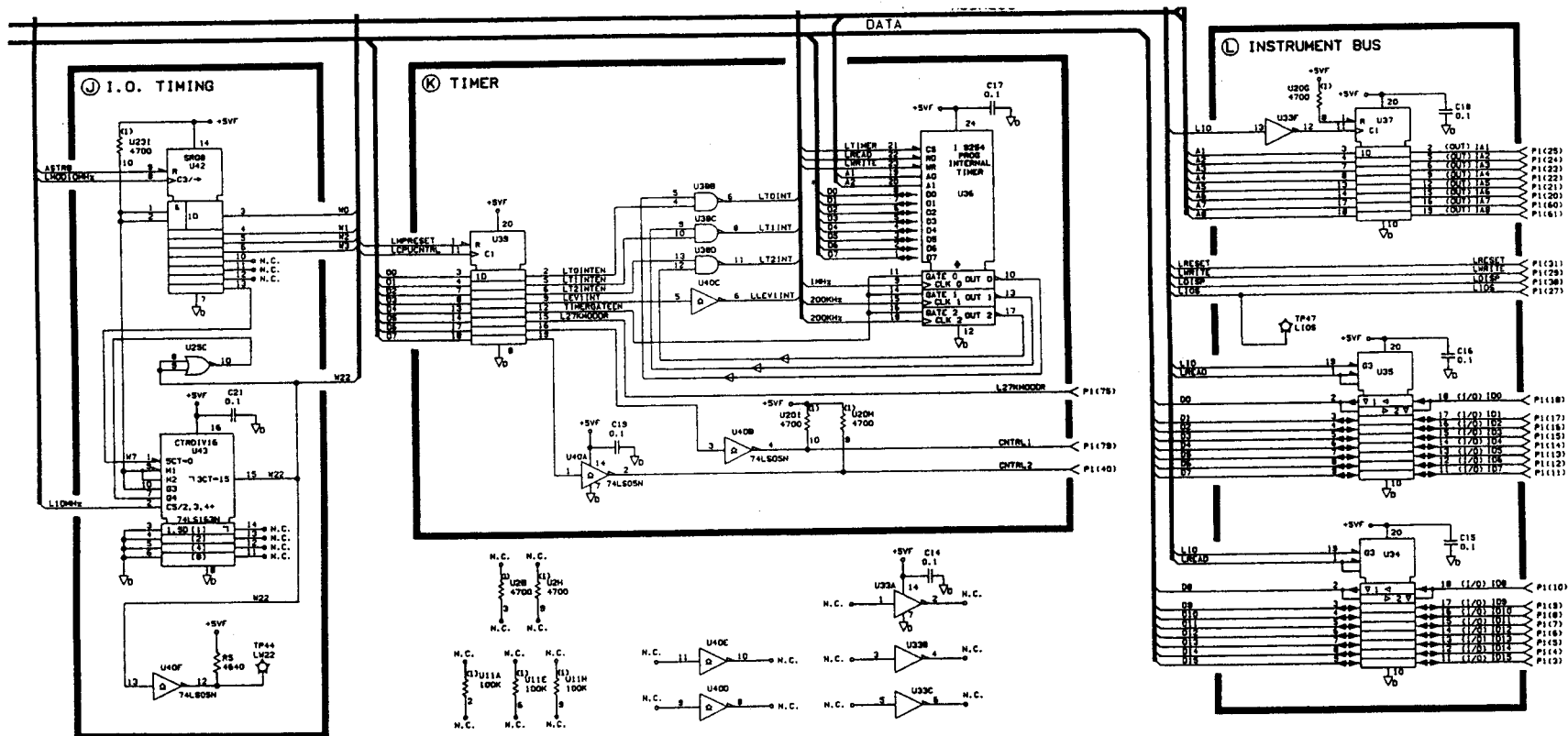




2 of 4 Bottom Left of Drawing







**A3 CPU**  
08757-60157

A3 Central Processing Unit (CPU), Schematic Diagram

## A4 Analog-to-Digital Converter (ADC)

### CIRCUIT DESCRIPTION

The A4 ADC schematic is documented on two pages. The first page (blocks A, B, C, D, E, F, G, and Q) covers the digital control, detector control, sweep functions, and power supply. These circuits track the horizontal sweep ramp and initiate the data acquisition function. The second page (blocks H through P) covers the analog, ADC, data acquisition, and blanking circuits. These circuits perform the vertical analog-to-digital conversion functions.

The A4 analog-to-digital converter (ADC) converts the A, B, C, and R analog outputs from the A7/A8/A9/A10 log amplifiers into digital information to be read, processed, and displayed by the A3 CPU. The SWEEP IN ramp and POS Z BLANK input from the microwave source are also processed by the A4 ADC. In addition, the detector control circuitry is located on this assembly. This circuitry controls and monitors the performance of the detectors.

The A, B, C, and R inputs are logarithmically shaped and DC rectified by the A7, A8, A9, and A10 log amplifiers respectively. These output a DC voltage representing the microwave power level at each input. The analog signals are converted to digital information at 101 to 1601 horizontal points (frequencies) per sweep. The SWEEP IN 0–10V ramp from the microwave source is used to determine when the analog signals should be sampled and digitized. The A3 CPU then reads the data, processes and formats it, and sends it to the A14 display for viewing. The POS Z BLANK, representing blanking and intensity marker information, is also processed on the A4 ADC.

### A. ADDRESS DECODER

The address decoder decodes the instrument bus address lines to select a single destination or source to write data to or read data from the instrument bus data lines.

Three-to-eight decoder U40 decodes address lines IA3 through IA8 to select one of eight devices on the A4 ADC assembly to read or write data on the data lines. The seventh line, L IOS, controls the timing of the enable pulses. U21A and U21B gate the enable pulses with the L WRITE line to allow only reads at those addresses. Table 8–18 lists the eight address decoder outputs, together with the appropriate hex addresses to activate them, and the functions they perform. Address lines IA1 and IA2 continue on to the control bus where they are later decoded.

### B. CONTROL DECODER

The data control register latches data from the instrument bus to control major ADC modes. Three control decoders, U36, U37, and U38, latch data from the instrument data bus at the rising edge of CNTRL WR1 and CNTRL WR2. Most of these lines control ADC and sweep/blanking functions. Two lines, L LOG ZERO and L LOG TEMP, exit the board to control the logger multiplexers on A7 thru A10. Other lines exit to the A5 modulator driver.

## C. STOP SWEEP

Stop sweep is both an input and an output. The A3 CPU can drive STOP SWEEP low through U24D to halt the sweep from the external source. Or, if the sweep is halted externally, the A3 CPU can sense this condition via the L STOP SWP line.

## D. DETECTOR CONTROL

The detector control circuitry allows the analyzer to monitor the detectors that are connected to it. If a compatible detector is connected, the A3 CPU can determine the type of detector (AC only or AC/DC); determine the diode sensitivity; determine the detector temperature; and control the mode of operation (AC or DC). All this can be accomplished using only the control line to the detector (CNTL A, B, C, or R). Current flow through this line is monitored by measuring the voltage drop across the 1.0 K sense resistors R19, R23, R27, and R31.

U34 is a quad 8-bit digital-to-analog converter. Each output can be addressed using IA1 and IA2. The output range is 0 V to +6.6 V with a resolution of about 26 mV. The output at U34 pin 2 is summed in U45A with an offset from R17. The output of U45A is then applied to sense resistor R19. Both sides of R19 are monitored by the ADC through multiplexer U31 and buffer U32B. The output of U32B is divided by 1.32 with R36 and R37. The sense side of R19 is static-protected by diodes CR1 and CR2 and becomes the CNTL A signal. The other outputs of U34, at pins 1, 20, and 19, go through similar circuits to produce the CNTL B, CNTL C, and CNTL R signals.

Analog multiplexer U46 allows three additional offsets to be summed together in U45. This gives three different ranges or modes of operation:

- Mode 1 = +10.13 V to +3.55 V at output of U45.
- Mode 2 = +3.29 V to -3.29 V at output of U45.
- Mode 3 = -3.55 V to -10.13 V at output of U45.

Each mode still retains the full 26 mV resolution. These different modes are used to monitor different characteristics of each detector.

## E. SWEEP DAC

The sweep DAC produces a stepped sweep voltage controlled by the A3 CPU. This voltage is compared with the sweep ramp from the source to determine the point in the sweep (frequency) where the inputs should be held and digitized.

The sweep DAC consists of the 12-bit current DAC U35 and the current-to-voltage converter U47. The A3 CPU controls the output voltage VDAC by writing the appropriate data to the data bus. U35 is a 12-bit multiplying DAC with complementary current-sink outputs. Its reference current comes from +DAC REF, which is approximately +10.24 V. U47 converts the DAC's current output to a voltage output in the range of 0 V to -10.24 V. R6 in the reference supply is adjusted to provide an output difference of -10.2375 V from the minimum to the maximum DAC output as measured at TP2 (DAC). The output voltage resolution is 2.5 mV.

Three other outputs are derived from VDAC (also known as DAC). VDAC2 is scaled to one-tenth of VDAC by voltage divider R7 and R8, for finer voltage increments. AUX DAC OUT goes to the rear panel where it is available at the DAC OUT 0–10V connector for troubleshooting or user convenience. This output is inverted from VDAC by U4D, and therefore has a range of 0 V to +10.24 V. VDAC3, used in testing the blanking/marker detector, is derived from U4C, which has a gain of  $-0.8$ . Its output voltage range is 0 V to +8.19 V.

In normal use the output of the sweep DAC follows the 0–10 V sweep input by using only 3200 of its 4096 possible values. The sweep comparator circuitry effectively compensates for this by using a lower value resistor on the VDAC input. Thus, for 100 trace points the DAC is incremented by 32 bits for each point (3200/100), while for 1600 trace points the DAC is incremented by only two bits for each point.

## F. SWEEP BUFFER

The sweep buffer buffers the 0–10 V sweep ramp from the source.

Swept microwave sources provide a 0–10 V x-axis sweep ramp representing frequency through the rear panel SWEEP IN connector. The center conductor and floating outer conductor are connected differentially to the A4 ADC assembly. Unity-gain buffers U43A and U43B provide high input impedance for the source. R51, R49, and C18 reduce common-mode noise. CR17, CR18, CR19, and CR20 clamp the lines to prevent damage from overvoltage. Open-collector comparator U12A grounds the SWP IN voltage during self-test; U12A pin 2 is open during normal operation. U25A is configured as a unity-gain, differential-input amplifier to reduce common-mode noise. The output at SWP is a 0 V to +10 V ramp with low output impedance. Pads are provided to add a resistor (R100) to divide the sweep input voltage if the ramp from the source is greater than +10 V. The voltage divider consists of R100 and R51. The value selected for R100 should limit the sweep ramp to +10.00 volts.

## G. SWEEP COMPARATORS

Sweep comparators compare the sweep DAC voltage with the 0V to +10V SWEEP IN ramp. The forward sweep comparator, via XCMP, sets the analog sample/hold to hold mode and begins the analog-to-digital conversion. The retrace comparator detects when retrace has begun.

The forward sweep comparator U12C detects the points in the sweep where the inputs should be digitized. The sweep DAC voltage and the SWP ramp are summed together at the non-inverting input of U12C. The inverting input of U12C is connected to ground. When the DAC voltage and the sweep voltage sum to 0 V, the comparator changes states. R63 provides hysteresis for noise immunity. At the start of the sweep, SWP IN and SWP are at 0 V dc. The sweep DAC voltage (VDAC) is set to about  $-0.175$  V dc. This partially compensates for the additional current flow through R58 and R59. While the sweep ramp is still at 0 V dc, the A3 CPU increments the DAC voltage until XCMP goes high, indicating that the sum of all the currents is zero (0 V dc at U12C pin 9). The DAC is then incremented to the first step in its staircase (this point varies depending on the number of trace points per sweep). When the sweep ramp reaches this first point (+0.025 V dc for 401 points per sweep), XCMP goes high initiating the measurement sequence. When this sequence is completed, the A3 CPU sets the DAC to the next point. This process continues until the sweep is completed.

Retrace comparator U12B operates much like U12C, except that it is slightly offset by R59. Thus RTRC stays low throughout the forward sweep while the sweep DAC is tracking the sweep input. At retrace, however, the SWEEP IN ramp reverses while the DAC voltage remains constant, causing U12B pin 1 RTRC to go high.

Since the sweep DAC's output is summed through a lower value resistor than the sweep input, the sweep DAC's voltage change over the 0–10 V sweep ramp is only 8 V ( $R57/R56 \times 10$  V).

## H. SAMPLE AND HOLD

Four identical amplifiers buffer the DC signals from the four log amplifiers. A fifth, nearly identical buffer is used for the AUX ADC IN input from the rear panel ADC IN connector. Sample/hold circuits sample these inputs and hold them for digital conversion when the sweep comparator detects a sampling point.

The A, B, C, and R inputs are logarithmically shaped and DC rectified by the A7, A8, A9, and A10 log amplifiers respectively. The log amplifier outputs are connected differentially to the buffers. Buffers U29A, B, C, and D are inverting, unity-gain amplifiers. Buffer U1 has a gain of  $-0.8$  and is protected against static by diodes CR9–CR12.

The sample/holds for the A, B, C, R, and AUX ADC IN inputs are U27, U26, U13, U44, and U2 respectively. Internally, each sampling switch includes an input buffer, switch, switch driver, and output buffer. A low-leakage external capacitor (C4–C8) holds the input voltage when L HOLD is asserted until L HOLD is released.

## I. ANALOG MULTIPLEXER

The analog multiplexer selects one of sixteen analog signals, including the A, B, C, and R inputs, for input to the ADC circuit.

Eight-channel analog multiplexer switches U15 and U14 select one of sixteen analog inputs to appear at their combined output. The input is selected by the binary-coded MPXA0, MPXA1, MPXA2, and MPXA3 lines from the multiplexer RAM U33, which receives its data from the data bus. See "L. Data Ready" for more information on the RAM sequence. When not enabled, the outputs of multiplexers U15 and U14 are open, and therefore, can be connected together in a wired-OR configuration. Table 8–17 lists the sixteen channels, the voltage ranges, and the binary select codes. Note that the SWP input is divided to 0.74 of its original value to prevent overloading of the ADC circuit.

U15 and U14 are followed by non-inverting buffer U3A. R47 and R46 give U3A a voltage gain of 1.2. This gain maintains all inputs to the ADC within the  $\pm 10$  V range.

## J. ADC

The analog-to-digital converter (ADC) circuit converts the selected analog input into digital form for the A3 CPU to read.

The ADC consists of sixteen-bit, successive-approximation, analog-to-digital converter U5. U5 contains its own internal conversion clock and analog reference. It is externally configured for a fifteen-bit short cycle, with an analog input range of  $\pm 10$  V dc. The data ready circuit sets L CONVERT low to begin an analog-to-digital conversion. When the conversion is done, U5 pulls pin 18 L CC (low = conversion complete) low, to be inverted by U9D and read by the data ready circuit and by the A3 CPU. The fifteen-bit digital output is a complementary offset binary output (TTL low=1, high=0). In this system, the digital outputs are all low with a +10 V dc input, all high with a -10 V dc input, and the MSB changes state at 0 V dc.

## K. OUTPUT DATA REGISTERS

The output data registers store and buffer data from the ADC to the A3 CPU on the instrument bus data lines.

The output data registers consist of four, four-bit-by-four, random-access memory packages U6, U7, U18, and U17. Each package has four, three-state outputs, and each output buffers one of the ADC data outputs. Altogether, sixteen lines are selected and buffered to drive the sixteen data lines of the instrument bus: fifteen from the ADC, and one (STTS FLG) from the status logic circuit. For further information, see "L. Data Ready".

## L. DATA READY

The data-ready circuit coordinates the data acquisition and output. This circuit directly controls the sample/hold, multiplexer, ADC, and output data registers. The data-ready circuit allows the conversion of up to four input channels without the need for the A3 CPU to intervene, thus reducing time and code complexity. Also contained in this block is the sweep-too-fast detector, which indicates when the sweep voltage is rising so fast that the A4 ADC does not have time to perform the data acquisition at all required frequency points on all input signals.

The first step in data acquisition is to indicate what inputs (out of sixteen possible) need to be measured. The four bits containing the multiplexer's address information are loaded into the multiplexer RAM U33 from ID0 —ID3. Address lines IA1 and IA2 determine the order in which the measurements are to be made. Thus up to four sets of four multiplexer addresses are stored in U33. On RAM U33, as well as on output registers U7, U6, U18, and U17, there are two different pairs of address inputs. Pins 13 and 14 select the address when data is to be loaded into RAM. Pins 4 and 5 select the address when the stored data is to be read from these random-access memory devices.

The next step in data acquisition is to determine how many inputs need to be digitized. Up to four inputs can be digitized during one cycle. The total number of inputs to be sampled is subtracted from 4, and that number is used to pre-load counter U41 via CVTC0 and CVTC1 (CVTC2 is used only for self-tests). When L XDAC WR goes low after each ADC conversion, this counter is incremented by one. When the output overflows to decimal 4 the data-ready line (DRDY) is high, indicating that all inputs have been measured (DRDY is actually the MSB of the three-bit counter). Thus, if a decimal 0 is pre-loaded into the counter, four measurements are made. If a decimal 3 is pre-loaded, only one measurement is made before DRDY goes high. The counter outputs (CVTA0 and CVTA1) are used to address both the input multiplexer and the output data registers.

Once the above information has been loaded, the A3 CPU writes its first value to the sweep DAC via L XDAC WR. In order to allow for DAC settling time, a 1.6 ms delay from U11A prevents XCMP from immediately going high and initiating the data acquisition cycle. This is accomplished with open-collector comparator U12D, which is connected to XCMP in a wired-OR configuration.

As the sweep ramp voltage increases, XCMP goes high indicating it is time for a data point to be measured. XCMP clocks a low to L HOLD through U23A, and this, in turn, causes the sample/hold circuits to hold their current inputs so that the ADC U5 can read them. L HOLD is used to generate an L CONVERT command to the ADC after a 3.6 ms delay from U42A to allow sufficient settling time for the sample/hold circuits. When the ADC U5 has completed its conversion (after about 50 ms) it pulls L CC low, which sets L DRWR high. After another 3.6 ms the L CONVERT line is enabled again for the next measurement. L DRWR also enables the output data registers to store the ADC reading in memory for later retrieval. The address in which this data is stored depends on the value of the counter outputs CVTA0 and CVTA1.

If more data is still to be read, the counter increments to its next address. This selects the next multiplexer output and the next output data register location. Now the L CONVERT line goes low again following its 3.6 ms delay from U42B. L CC goes low again indicating a conversion was made, and the counter U41 increments by one count. This sequence continues until the counter output reaches a decimal count of 4, at which time DRDY goes high indicating the end of a series of conversions and generating an interrupt to the A3 CPU. The CPU can then read back all four data measurements stored in the output data registers.

Now the sweep DAC needs to be updated to its next measurement point. This occurs when L XDAC WR goes low, which also resets U11, U23, and U41.

The sweep-too-fast detector circuit is composed of U11B and U23B. This circuit detects when the sweep input is rising too fast for the ADC. The SWEEP TOO FAST line is set true whenever XCMP goes high within 3.2 ms ( $2 \times 1.6$  ms) after the sweep DAC was set (when L XDAC WR was low). U23A pin 11 clocks the current condition of XCMP through to pin 9. If XCMP is low then SWEEP TOO FAST is low; if XCMP is high then SWEEP TOO FAST is also high.

## O. BLANK/MARKER DETECTOR

The blank and marker detector decodes the POS Z BLANK (PZAB) input from the source for blanking, marker, and active marker conditions.

The POS Z BLANK rear panel BNC input receives display blanking and intensity marker information from the source. The following are the four possible levels:

- +5 V dc =Blank (retrace and bandswitch points).
- 0 V dc =Display (normal trace, forward sweep).
- -4 V dc =Markers (intensity markers).
- -8 V dc =Active marker (high-intensity marker).
- These levels are detected with three voltage comparators, U24A, B, and C. R69 puts PZAB at 0 V dc (display) when no input is connected. C23 reduces noise; CR2 and CR23 prevent overvoltage damage. R70 and R71 form a voltage divider between the PZAB input and +15 V dc, offsetting the bipolar PZAB input to a unipolar line. After offsetting, the following levels occur at the three comparators during the indicated conditions:



- +8.8 V dc =Blank.
- +5.7 V dc =Display (normal).
- +3.26 V dc =Markers.
- +0.79 V dc =Active markers.
- Resistive string R72, R73, R74, and R75 in the power supply block establishes the reference voltage for each comparator. U24A is biased at +7.6 V dc; its output BLNK is normally low, and goes high when blanking occurs. U24B is biased at +4.5 V dc; its output is normally low, and goes high when a marker or active marker occurs. The rising edge clocks flip–flop U22A, setting U22A pin 5 MKR high if MKR EN is high. U24C is biased at +1.9 V dc; its output is normally low, and goes high when an active marker occurs. The rising edge clocks U22B, setting U22B pin 9 ACT MKR high if MKR EN is high. The A3 CPU reads these three outputs through the status buffer and takes the appropriate action. Afterward, the A3 CPU resets U22A and U22B by pulsing L MKR RST (low =marker reset) low.
- Analog switch U46D is closed only during self–test. It connects the sweep DAC voltage to the inputs of the comparators, overriding any input at the rear panel connector and allowing the A3 CPU to exercise all blank and marker detector circuitry.

## M. STATUS BUFFER

The status buffer allows the A3 CPU to read status information, including blanking and markers, from the A4 ADC.

Three–state buffer U19 sends the status of eight lines on the A4 ADC assembly to the A3 CPU via the instrument bus data lines whenever L STTS RD goes low.

## N. INTERRUPT LOGIC

The interrupt logic allows the A4 ADC to interrupt the A3 CPU if one of several conditions has occurred. Two interrupt lines connect the A3 and A4 assemblies together. The first, L DRINT, is the data–ready interrupt which signals the A3 CPU that the ADC has completed its measurement cycle. The second, L STTS INT, indicates one of four different events: blanking, not blanking, marker, and retrace. These events are OR'd together in U10 so that any one can generate an interrupt. Any one or more of these interrupts can be enabled by the A3 CPU with the appropriate interrupt enable line (BLNK IEN, UNBLNK IEN, MKR IEN, or RTRC IEN). The interrupt enable line is then clocked through flip–flops U20A and U20B by the actual event, thus interrupting the A3 CPU if the interrupt enable line is high. The data–ready flip–flop U20A is cleared when the CPU reads the ADC data (when L DRRD goes low). The status interrupt flip–flop U20B is cleared when the CPU reads the status buffer (when L STTS RD goes low).

## P. STATUS LOGIC

The status logic allows the A3 CPU to monitor different events without being interrupted. The marker, blanking, retrace, and sweep–too–fast status lines are OR'd together by U8 and U9. CVTA0 and CVTA1 allow the status flag to be set only on the last of the four possible measurement cycles. L STTS FLG is then read by the A3 CPU when it reads the ADC data.

## **Q. POWER SUPPLY FILTERING**

The power supply filtering circuit removes unwanted noise from the voltage supply lines used on the A4 ADC assembly.

LC filters remove noise from the +15VF, +5VF, -15VF, and +5VD lines. A pull-up resistor R82 generates +5VP, which is used as a TTL high. Voltage reference U16 generates a +10 V reference. This is amplified slightly by U4B to produce +DAC REF, which is approximately +10.24 V and is used for the sweep DAC. This is then divided by R14 and R15 and buffered by U4A, producing the +6.6 VREF used on the detector control DAC. R72, R73, R74, and R75 produce three reference voltages from the +15VF line to be used mainly by the blank/marker detector.

## A4 Diagnostic Tests

These keys are accessed by pressing **SYSTEM** **MORE** **SERVICE** **A4 ADC**.

### ADC MEAS

This diagnostic test checks the ability of the A4 ADC to properly convert an analog signal to digital data. The routine consists of two separate tests. See "**DATA READY**" and "**READ DATA**".

### ADC BIT CHECK

This checks the ability of all fifteen data lines of the ADC U5 to toggle both high and low. The test ramps the sweep DAC U35 while selecting both the VDAC2 and VDAC3 inputs to the ADC. Each bit of the ADC must be capable of outputting both high and low logic levels. Any bit not capable of this is listed on the CRT. The failed bit position is indicated by a "1" in the appropriate location of the error message.

### DAC BIT CHECK

This test checks the accuracy of the sweep DAC U35 and the four Channels of the detector control DAC U34. Each bit is checked for its proper weighting. Bits that fail are listed on the CRT. A "1" indicates a failed bit position.

### DET CONTROL

This cycle test verifies the performance of the detector control circuitry up to and including the four outputs of U45. During this test the detector DAC U34 and the mode switch U46 are exercised over their entire range. The resulting output (as viewed at pin 3 of the detector input connectors on the front panel) is shown in Figure 8-16.

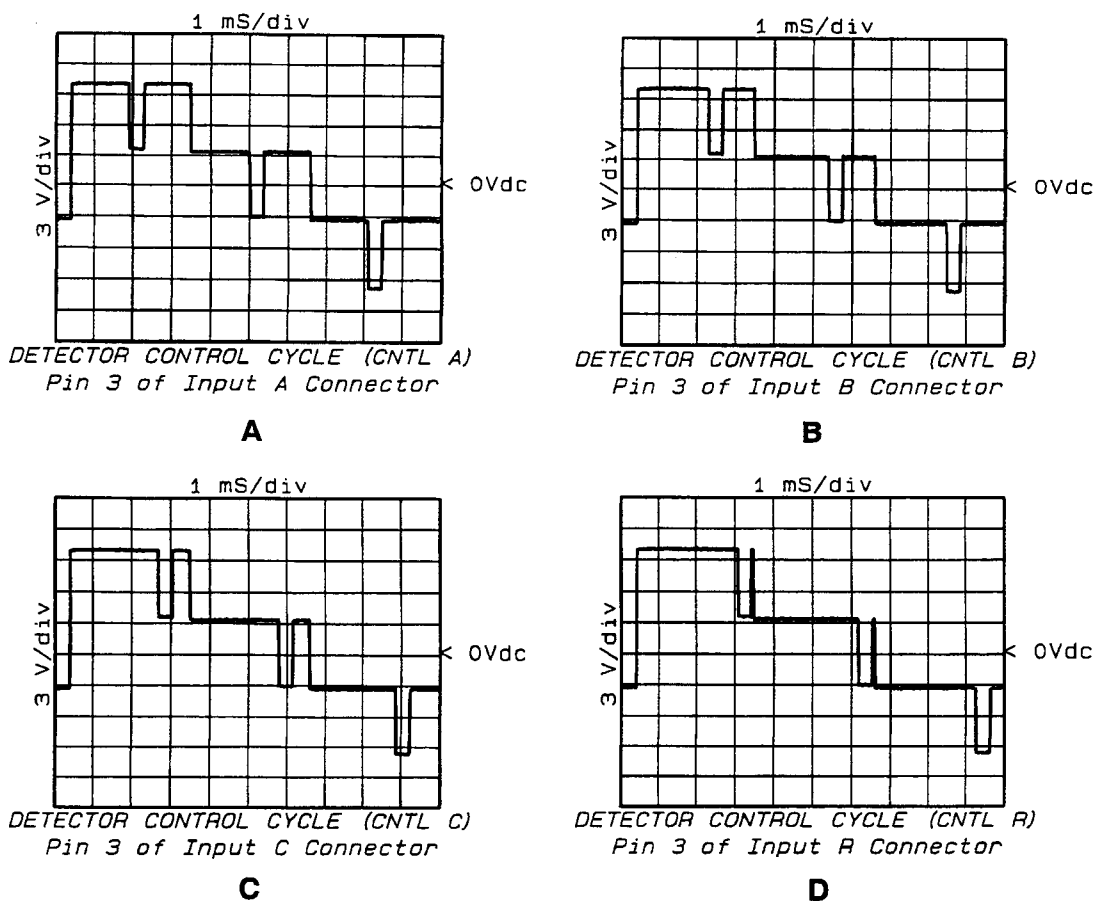


Figure 8-16. Detector Control Cycle Waveforms

If the test fails, the failure mode is displayed together with more softkeys. These keys select one of three modes of operation corresponding to the three sections of the mode switch U46. When one of these keys is pressed, the display indicates which portion of which input channel control line has failed. Another softkey is available to access the channel volts/detector DAC test. Table 8-13 shows the expected voltage output from each section of U45 (each input channel).

Table 8-13. A4 Detector Control Modes

	MAX V	MIN V	U46 (Closed Section)
Mode 1	+10.17	+3.57	1. pins 3 & 2
Mode 2	+3.28	-3.31	2. pins 6 & 7
Mode 3	-3.67	-10.27	3. pins 11 & 10
MAX = All DAC bits low MIN = All DAC bits high			(Only one section is closed at a time).

## SWEEP COMPARE

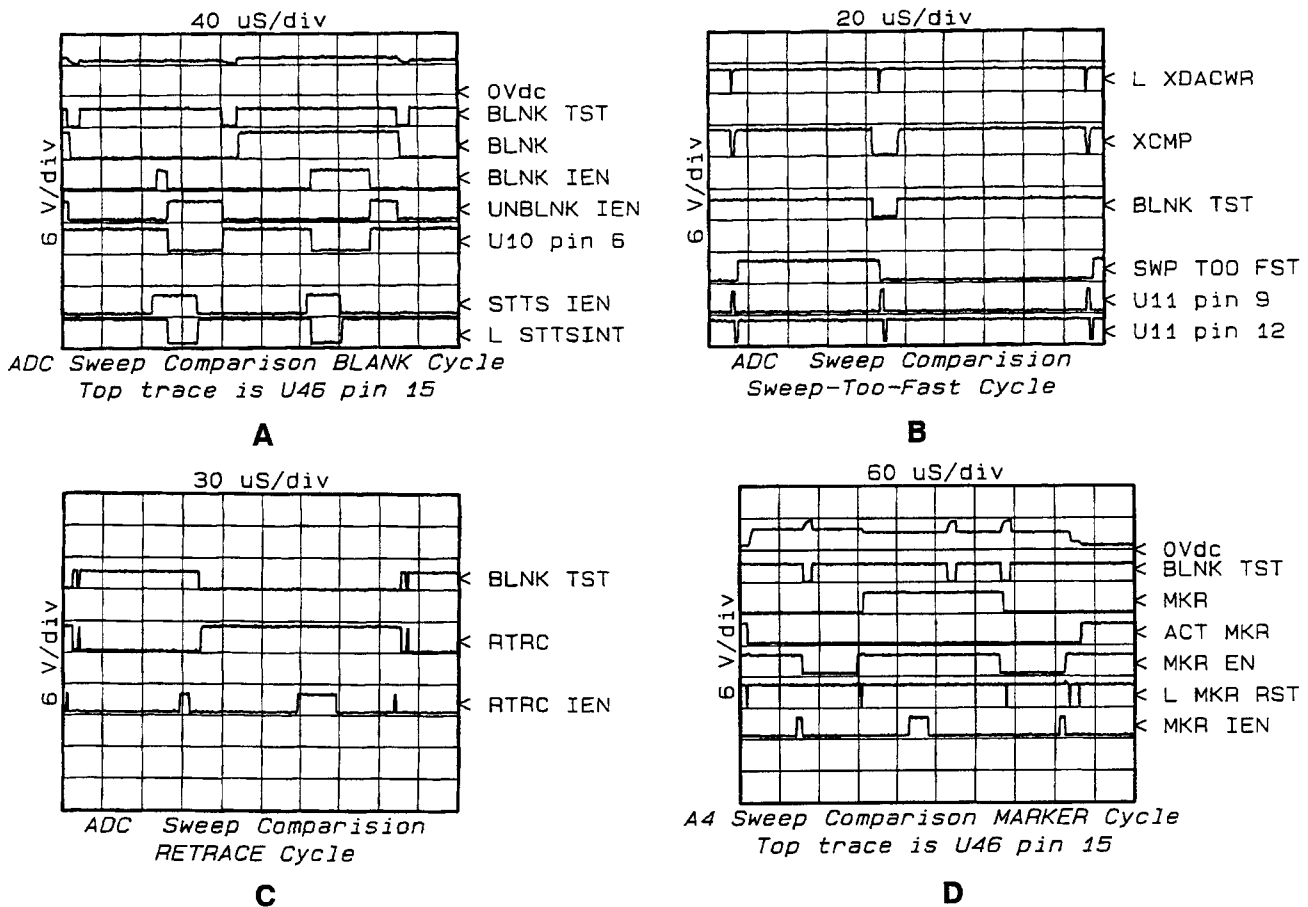


Figure 8-17. Sweep Comparison Cycle Tests Waveforms

**SWEEP COMPARE** performs a large number of tests that verify the operation of most of the sweep control, blanking, and marker circuitry. If any portion of the tests fails, the results are displayed on the CRT. In addition, several more softkeys are then available to further isolate the problem. These softkeys call up cyclical routines to aid in troubleshooting. Typical waveforms for the sweep comparison tests are shown in Figure 8-17.

**NOTE:** Many of these sweep compare diagnostic tests require a properly working sweep DAC and its scaled outputs VDAC, VDAC2, and VDAC3. These outputs are used to test the voltage thresholds of several different comparators. Other tests use switches or comparators to toggle control lines. Failure of any of these components causes a failure of the test.

Table 8-14 shows the circuits checked during this routine in order of execution.

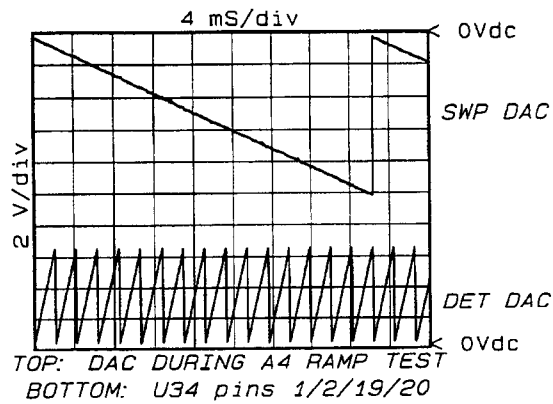
**Table 8–14. Sweep Compare Failure Chart**

<b>Test</b>	<b>Areas of Most Probable Failure<sup>1</sup> (other than actual self–test devices)</b>
Stop sweep circuitry <sup>2</sup>	U24D, U19A
Sweep compare	U12C
Status flag	U8, U9
Status	U19
Interrupt	U9, U10
Blanking	
Status flag	U8, U9E, U24A
Status	U19A
Interrupt	U9C, U10, U20B
Unblank	U9B
Sweep too fast	
Status flag	U11B, U23B, U8A
Status	U19B
Retrace	
Status flag	U12B, U8
Status	U19A
Interrupt	U10
Marker	
Status flag	U24B, U22A, U8B
Status	U19B
Interrupt	U10
Active marker status	U22B, U19B
Marker disable	U22

1. Also check control decoders U36, U37, and U38 for proper decoding of control lines.
2. Rear panel STOP SWEEP BNC must be disconnected for this test to pass.

## **RAMP**

This cyclical test continuously ramps the sweep DAC U35 and the detector control DAC U34 from their minimum value to their maximum. Typical outputs are shown in Figure 8–18. Note that because the detector DAC is only eight bits and the sweep DAC is twelve bits, the detector DAC completes sixteen ramp cycles per sweep DAC ramp.



**Figure 8–18. DAC Waveforms during A4 Ramp Test**

## CHANNEL VOLTS

This softkey leads to another menu to access a series of cyclical tests. These tests allow the operator to monitor various inputs to the ADC U5 under varying conditions. Typical CRT displays with no external inputs connected are shown in Figure 8–19. The actual input voltage to the ADC U5 or the multiplexer U14/U15 may be different from the CRT display. This is due to the different scaling factors used in different parts of the circuit.

```

MORE ADC TESTS                                     CHANV
CHANV LOGGERS                                       LOGGER

INPUT A
  Data:      -6.187 V
  DC Offset: -7.791 V
  Temp:      -1.771 V
INPUT B
  Data:      -6.479 V
  DC Offset: -7.774 V
  Temp:      -1.704 V
INPUT C
  Data:      -6.302 V
  DC Offset: -7.783 V
  Temp:      -1.696 V
INPUT R
  Data:      -6.095 V
  DC Offset: -7.782 V
  Temp:      -1.654 V
                                                    CHANV
                                                    DETDAC
                                                    OTHER
                                                    PRIOR
                                                    MENU
                                                    EXIT
                                                    SERVICE

```

A

```

MORE ADC TESTS                                     DET DAC
CHANV DETDAC                                       ENTER

DET DAC ENTRY:  -0.00 V
Use step keys or keypad to vary
Detector DAC voltage. Terminate
with DET DAC ENTER softkey.
-----
DETECTOR:      MODE 2
INPUT A SENSE: +0.07 V
          DRIVE: +0.07 V
INPUT B SENSE: +0.04 V
          DRIVE: +0.04 V
INPUT C SENSE: +0.05 V
          DRIVE: +0.05 V
INPUT R SENSE: +0.09 V
          DRIVE: +0.09 V
                                                    DET DAC
                                                    MAX
                                                    DET DAC
                                                    MIN
                                                    MODE 1
                                                    MODE 2
                                                    MODE 3
                                                    PRIOR
                                                    MENU
                                                    EXIT
                                                    SERVICE

```

B

```

MORE ADC TESTS                                     SWP DAC
CHANV OTHER                                       ENTER

SWEEP DAC ENTRY: -10.2375 V
Use step keys or keypad to vary
Sweep DAC voltage. Terminate
with SWEEP DAC ENTER softkey.
-----
          VDAC2:  -1.0258 V
          SWP DAC: -10.2500 V
                                                    SWP DAC
                                                    MAX
                                                    SWP DAC
                                                    MIN
                                                    PRIOR
                                                    MENU
          6.6VREF: +6.5745 V
          GND:     -0.0020 V
AUX ADC IN:  +0.0038 V
SWEEP IN:    +0.0205 V
                                                    EXIT
                                                    SERVICE

```

C

Figure 8-19. A4 Channel Volts Tests



## CHANV LOGGER

This test monitors the output of each logger in each of the three states: data, DC offset, and temperature. The voltage displayed should correspond to the output of the log amplifier assembly at TP9 on A7, A8, A9, and A10.

## CHANV DETDAC

This test monitors the voltage at both the driven and sensed sides of the detector control sense resistors A4R19, R23, R27, and R31. The detector mode switch U46 can be set to any mode and the DAC U34 can be set to any valid value within its mode range. (Refer back to the detector control test for voltage limits.) The output voltages of U45 (the DRIVE side of the sense resistors) are then displayed, along with the voltages at the SENSE side of the sense resistors. The drive voltage should be about the same voltage as the DAC setting. The sense voltage depends upon the load (detector) connected to the appropriate front panel input connector. If the connector is not terminated, the two readings should be the same, as there is no voltage drop across the sense resistor. If the connector is shorted to ground, the reading is zero. If an HP 11664A detector (serial number 25000 or above) or 11664E is connected, the sense voltage is one half of the drive voltage because the HP 11664A/E contains a 1K ohm internal resistor to ground.

The test starts in mode 2 with the DAC set to its mid point. This gives approximately zero volts output for the drive voltage. Any significant variation from zero indicates an offset problem. The DAC output voltage can be stepped one bit at a time using the STEP keys. Each step corresponds to an output change of 26 mV.

## CHANV OTHER

This test monitors other miscellaneous inputs to the ADC. Also the minimum and maximum sweep DAC output values can be set using the softkeys. The sweep DAC U35 can be set manually using the **SWP DAC ENTER** key and the keypad or STEP keys. Each step changes the DAC output by 2.5 mV. Note that the sweep DAC output is always a negative voltage, therefore the maximum voltage setting is 0 V while the minimum voltage is  $-10.2375$  V.

The following points are monitored:

**VDAC2:** This voltage should be one tenth of the sweep DAC setting indicated at the top of the CRT. The ratio is determined by A4R7 and R8 (9K and 1K ohms).

**SWP DAC:** This voltage should be about the same as the voltage indicated on the CRT for the sweep DAC (also known as VDAC or DAC-A4TP2). The displayed voltage is actually a measurement of VDAC3 multiplied internally by  $-1.25$  to compensate for the effects of A4U4C.

**6.6VREF:** This monitors the 6.6 V reference voltage used for the detector control DAC U34. The voltage should be within 0.1 V of 6.6 V.

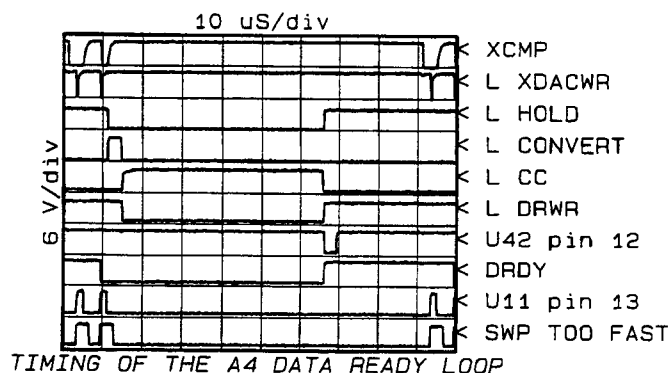
GND: This monitors the ground reference point. Typically this is within a few millivolts of 0 V.

AUX ADC IN: This monitors the AUX ADC input voltage from the rear panel ADC IN connector. The maximum input reading is  $\pm 10.417$  V.

SWEEP IN: This monitors the sweep input voltage from the rear panel.

## DATA READY

This cycle test verifies the ability of the ADC U5 to properly complete one analog-to-digital conversion. This is a digital test. The accuracy of the conversion is not checked in this routine, only the proper sequencing of the digital control lines.



*Figure 8–20. Timing of the A4 Data Ready Loop*

The digital timing and sequence of events for several control lines is shown in Figure 8–20. Table 8–15 shows the items that are checked.

*Table 8–15. Data Ready Failure Chart*

Control Line	Probable Cause of Failure
XCMP	U12C/D, U19, U11A
DRDY	U42, U39, U41
SWP TOO FAST	U11B, U23B
Set–L DRINT	U20A
Clr–L DRINT	U21B
ADC Timeout	U5

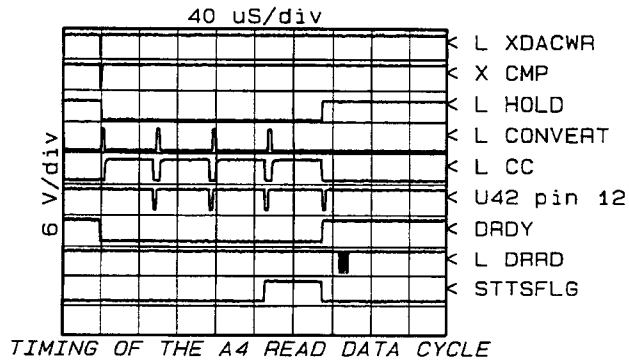
The ADC timeout test verifies that the ADC can complete a conversion cycle within 60 ms.

## READ DATA

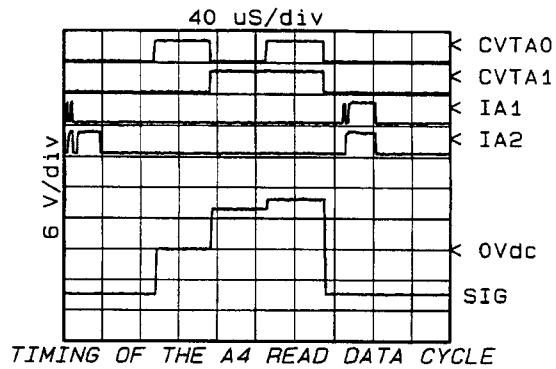
This cyclical test verifies the ability of the A4 ADC to accurately complete a full cycle of four conversions. This routine verifies most of the analog multiplexer, ADC, data ready circuit, and output data register (blocks I, J, K, and L). The 6.6 V reference, the detector control DAC U34, and the sweep DAC U35, along with their associated circuits, must already be working properly for this test to pass. A conversion is made on the inputs listed in Table 8–16 of the analog multiplexer U15/U14. The voltages indicated are those present at the input to the multiplexer. The test fails if the voltage read is outside the limits shown. The actual voltage at the input to the ADC itself is 20% higher.

*Table 8–16. Read Data Tests*

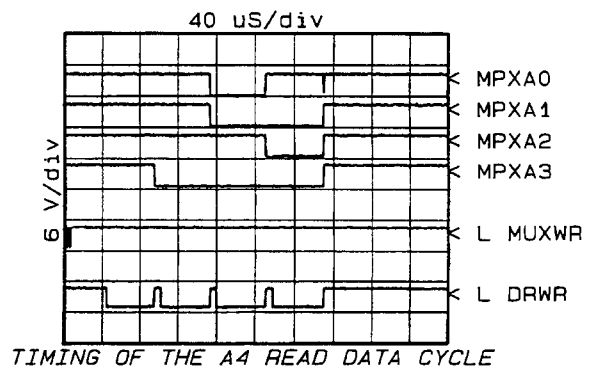
Reading	Input	Expected Voltage
DPS2	Detector C DAC is set to its near maximum negative voltage of $-10.24$ V.	$-7.80 \pm 0.5$ V at U14
GND	Analog ground input.	$0.00 \pm 0.065$ V
6.6VREF	Reference voltage input.	$+6.6 \pm 0.3$ V
VDAC3	Sweep DAC set to its maximum negative voltage of $-10.2375$ V, inverted by buffer U4C to $+8.19$ V.	$+8.19 \pm 0.14$ V



**A**



**B**



**C**

**Figure 8-21. Timing of the A4 Read Data Loop**

## A4 Troubleshooting

The A4 ADC schematic is documented on two sheets. The first page (blocks A, B, C, D, E, F, G, and Q) covers the digital control, detector control, sweep functions, and power supply. These circuits track the horizontal sweep ramp and initiate the data acquisition function. The second page (blocks H through P) covers the analog, ADC, data acquisition, and blanking circuits. These circuits perform the vertical analog-to-digital conversion functions.

### BASIC CHECKS

Check the power supply voltages to the A4 ADC assembly, especially the  $\pm 15$  V supplies. Check that the +10VREF voltage at A4TP3 (+10) is  $+10.00 \pm 0.05$  V.

### SELF-TEST AND ERROR MESSAGES

If any self-test fails at preset or turn-on, refer to "Self-Tests" at the beginning of the service Chapter. The following instrument verify error messages usually apply to A4 ADC failures:

- ADC Measurement.
- ADC Bit Check.
- DAC Bit Check.
- Sweep Compare.
- Detector Control.

These tests are similar to the ones described in the ADC diagnostic tests.

**NOTE:** Failure of *all* the above self-tests usually indicates the failure of the ADC U5 to perform a conversion.

The internal instrument verify test (performed at preset or turn-on) is a very comprehensive test designed to detect almost any hard failure in either the digital or analog portion of the assembly. ADC accuracy is also verified within certain limits. In fact, the only portion of the assembly *not* thoroughly tested is the sample/hold circuit and part of the stop sweep circuit. However, the stop sweep circuit is checked when the sweep compare diagnostic test is performed (with the STOP SWEEP BNC cable disconnected). The sample/hold circuit is easily checked by viewing the displayed voltages for each input while a known power level is applied to each input with a detector. This procedure is explained later in this Chapter.

If any of the above self-tests fails, go to the A4 service menu using **SYSTEM MORE SERVICE A4 ADC** and run the appropriate diagnostic test. This should isolate any failure to a specific portion of the ADC assembly. Compare the results of the cyclical tests with Figure 8-16 through Figure 8-21. Trigger the oscilloscope with the CONTROL 1 negative-edge output signal from the rear panel.

## CIRCUITS NOT CHECKED BY SELF-TESTS

Use the troubleshooting setup shown in Figure 8–5, “HP 8757D Overall Troubleshooting Block Diagram”. Set the sweep time to 150 ms minimum.

### Sweep In

Verify that the sweep ramp from the source is 0 V to +10 V (Figure 8–23) both at the input to the ADC board and at TP10 (SWP). If there is no sweep ramp, no horizontal trace can appear on the CRT (except in CW mode).

### Stop Sweep

Terminate the STOP SWEEP BNC output on the rear panel with either a short or a 50 ohm load. Then verify that the stop sweep line reaches the rear panel by performing the sweep compare test. To access this test, press **SYSTEM** **MORE** **SERVICE** **A4 ADC** **SWEEP COMPARE**. The test should fail when the STOP SWEEP connector is terminated, and pass when it is disconnected.

## ADC IN and DAC OUT

Connect a BNC cable from the DAC OUT 0–10V connector on the rear panel to the ADC IN connector. You can also connect a voltmeter to check accuracy, using a BNC tee. Run the CHANV OTHER diagnostic test using **SYSTEM** **MORE** **SERVICE** **A4 ADC** **MORE** **CHANNEL VOLTS** **CHANV OTHER** and set the sweep DAC to its minimum setting (–10.2375 V). The AUX ADC IN reading (and the voltmeter reading) should then be within a few millivolts of the sweep DAC setting. Vary the sweep DAC output voltage over its range using either the STEP keys or the keypad.

## Logger Sample/Hold Circuits

To verify the accuracy of the sample/hold circuits on the log amplifier assemblies, run the CHANV LOGGER diagnostic test. Vary the detector input power over its range and verify that the data reading of the corresponding input changes from about +6.5 V at +10 dBm to about –6 V (noisy) at –60 dBm. Note that the change per dB is not linear.

If greater accuracy is desired, monitor the appropriate log amplifier assembly output with a voltmeter at TP9 in the normal measurement mode (not in the service menus). (The logger output is actually a differential signal.) Then return to the CHANV LOGGER diagnostic test and compare the two voltage readings. The voltage reading at TP9 on the logger assembly is not accurate while the CHANV LOGGER service menu is present, because three separate voltages are multiplexed.

## BLOCK-BY-BLOCK TROUBLESHOOTING

### A. Address Decoder

In the READ DATA diagnostic test, verify the presence of negative-going pulses at each output of U40, except for pin 7 L MKR RST. If the pulses are not present, suspect U40 or the incoming address lines.

## B. Control Decoder

The control decoder outputs are most easily checked by using the hex data rotate routine. Enter the hex tests menu using **SYSTEM** **MORE** **SERVICE** **HEX TESTS** . Enter the address 1FF848 and press **ROTATE** . A positive-going pulse should be visible at each output of U38 (a walking 1 pattern). Repeat this test at address 1FF868 and verify each output of both U37 and U36.

## C. Stop Sweep

See “Stop Sweep” under “Circuits Not Checked by Self Tests” at the beginning of this troubleshooting Chapter.

## D. Detector Control

Using the **RAMP** diagnostic test, verify a 0 V to +6.6 V ramp at each of the four outputs of U34.

Measure the voltages on pins 3, 6, and 11 of the detector mode switch U46. These should be 0 V at pin 3, -2.59 V at pin 6, and -5.18 V at pin 11. Use the CHANV DETDAC diagnostic test to select modes 1, 2, and 3. Depending on which mode is selected and therefore which switch Chapter in U46 is closed, the non-inverting inputs of U45 should have the same voltage as one of the input pins (3, 6, and 11). Mode 1 closes switch Chapter 1 only, mode 2 Chapter 2 only, and mode 3 Chapter 3 only.

Use an oscilloscope to check the detector control outputs on pin 3 of each detector input connector. The waveforms should be similar to Figure 8-16.

## E. Sweep DAC

Enter the RAMP diagnostic test, and verify the presence of a 0 V to +10.2375 V ramp at TP2 (DAC).

- VDAC2 should be one-tenth of the voltage at TP2.
- VDAC3 should be inverted and be 80% of the voltage at TP2.
- AUX DAC OUT should be inverted from TP2.

## F. Sweep Buffer

This differential buffer has a gain of 1. Verify that the SWP IN signal looks identical to the signal at TP10 (SWP).

## G. Sweep Comparator

Enter the sweep comparison test using **SYSTEM** **MORE** **SERVICE** **A4 ADC** **SWEEP COMPARE** . Then run the **BLANK** , **SWP TOO FAST** , **RETRACE** , and **MARKER** diagnostic tests. Compare the RTRC and XCMP (TP11) waveforms for each test with Figure 8-17.

## H. Sample/Hold

These differential buffers each have a gain of  $-1$  except for U1 which has a gain of  $-0.8$ . Verify that the output is similar to the input signal but with opposite polarity.

## I, J, K, L. Data Acquisition

(Analog multiplexer, ADC, output data register, data ready circuit.) The data acquisition function is a complex series of events involving several circuits and assemblies. Since the components of the data acquisition chain are arranged in a loop, a failure in any one component may create failure symptoms throughout the entire loop. The following procedure should isolate the problem to a small link of the chain.

First, perform the **DATA READY** diagnostic test. If this test passes it indicates the proper operation of the data ready circuit, the ability of the ADC to perform a conversion (but not the accuracy), and the operation of the interrupt logic circuit. If any portion of the test fails, use an oscilloscope to compare the timing waveforms to Figure 8–20. This should quickly isolate any problem to one or two ICs.

Second, perform the **READ DATA** diagnostic test. This test verifies the accuracy of four ADC conversions, the operation of the multiplexer, and the operation of the output data registers.

Failure of all the tests may indicate a problem with the ADC or one of the control address lines (CVTA0, IA1, MPXA0, etc.). Use an oscilloscope to compare the waveforms with Figure 8–21. In particular, check for the presence of CVTA0, CVTA1, IA1, and IA2 at each of the RAMs (U33 in block I, and U7, U6, U18, and U17 in block K).

If only one of the four measurements fails, check the voltage levels at the appropriate input to the multiplexer.

## N, M, P. Interrupt and Status

These circuits are thoroughly tested during self–test. If a problem arises, verify the continuity of all related control lines. If continuity is verified, suspect the IC controlling the indicated function.

## O. Blank/Marker Detector

This circuit is also thoroughly tested during self–test. If a failure occurs check the reference voltages, VDAC3, and the continuity of PZAB from R69 to the rear panel.

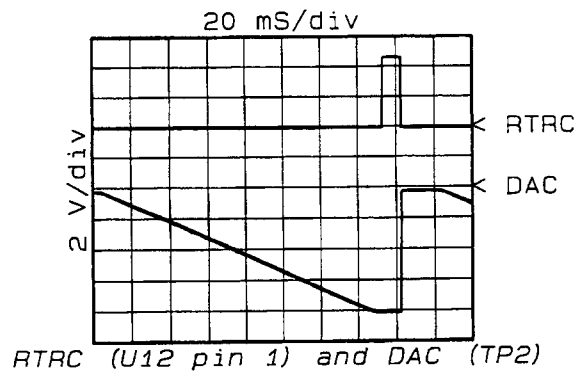
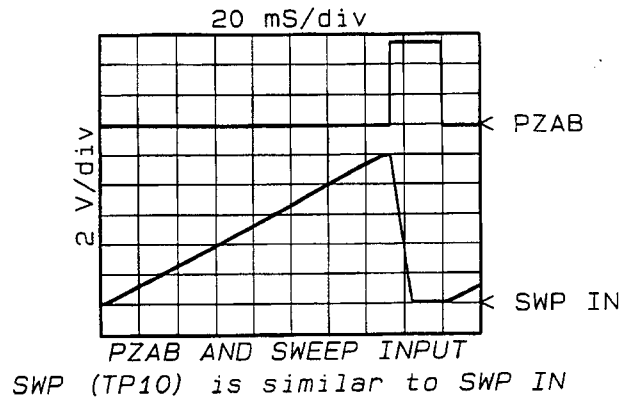


**Table 8–17. A4 Multiplexer Channels**

MPXA3	MPXA2	MPXA1	MPXA0	Description		Typical Voltage Range at U14, 15
0	0	0	0	VDAC 2	Sweep DAC ÷ 10	0 to –1.02 V
0	0	0	1	VDAC 3	Sweep DAC x –0.8	0 to +8.2 V
0	0	1	0	NC		
0	0	1	1	NC		
0	1	0	0	+6.6VREF	Detector DAC Reference Voltage	Nominal +6.6 V
0	1	0	1	NC		
0	1	1	0	CAL PWR	A5 Control Opt. 002 only	
0	1	1	1	GND A	ANALOG GND	0.0 V
1	0	0	0	B HOLD	Sample/Hold from B Logger	App. –7.5 at +20 dBm detector input. App. +6.1 V at noise floor (–62 dBm).
1	0	0	1	C HOLD	Sample/Hold from C Logger	
1	0	1	0	A HOLD	Sample/Hold from A Logger	
1	0	1	1	R HOLD	Sample/Hold from R Logger	
1	1	0	0	AUX HOLD	Sample/Hold from AUX ADC ON	±8.0 V
1	1	0	1	SWP	Buffered Sweep Ramp	0 to +7.5 V
1	1	1	0	DPS1	Detector Parameter Sense 1	±7.7 V
1	1	1	1	DPS 2	Detector Parameter Sense 2	±7.7 V

**Table 8–18. A4 Address Decoder Lines**

Mnemonic	Address Hexadecimal	Destination	Description
L XDAC WR	1FF240	U11, U23, U35, U41	Enables writing of data to sweep DAC.
CNTRL WR1	1FF848	U38	Enables decoding of 8 data lines at U38.
L DRRD	1FF850 – 1FF854	U6, 7, 17, 18, 20	Enables reading of ADC data lines.
L STTS RD	1FF858	U19, U20	Enables reading of status buffer U19.
L MUXWR	1FF860 – 1FF866	U33	Enables writing of data to multiplexer RAM.
CNTRD WR2	1FF868	U36, 37	Enables decoding of 16 data lines at U36, 37.
L DDAC WR	1FF070 – 1FF076	U34	Enables writing of data to detector control DAC.
L MKR RST	1FF878	U22	Resets marker detectors.



**Figure 8-22. A4 ADC Sweep-Related Waveforms (Sweep Time 150ms)**

Table 8-19. A4 Pin-Outs (1 of 3)

A4P1

PIN	SIGNAL	I/O	SOURCE/ DESTINATION	FUNCTION BLOCK
1 19	AUX ADC IN CNTL R	IN OUT	A11J8-58 A11J1-33	H D
2 20	AAI SHLD CNTL B	IN OUT	A11J8-57 A11J1-34	H D
3 21	CAL PWR CNTL A	IN OUT	A5P1-22 A11J1-31	I D
4 22	ATTN BIAS NC	OUT	A5P1-4	E
5 23	ATTN 20 ATTN EN	OUT OUT	A5P1-23 A5P1-23	B B
6 24	ATTN 1 CNTL C	OUT OUT	A5P1-24 A11J1-32	B D
7 25	CAL ON NC	OUT	A5P1-25	B
8 26	GND A GND A	IN IN	A11J6-12* A11J6-12*	Q Q
9 27	LOG A LOG A COM	IN IN	A7P1-35 A7P1-34H	H H
10 28	LOG B LOG B COM	IN IN	A8P1-35 A8P1-34	H H
11 29	LOG C LOG C COM	IN IN	A9P1-35 A9P1-34	H H
12 30	LOG R LOG R COM	IN IN	A10P1-35 A10P1-34	H H
13 31	NC NC			
14 32	GND A GND A	IN IN	A11J6-15 A11J6-15	Q Q
15 33	+15V +15V	IN IN	A11J6-14 A11J6-14	Q Q
16 34	-15V -15V	IN IN	A11J6-13 A11J6-13	Q Q
17 35	GND GND	IN IN	A11J6-12 A11J6-12	Q Q
18 36	+5V +5V	IN IN	A11J6-11 A11J6-11	Q Q

\*Multiple destinations, refer to wiring schematic.

Table 8-19. A4 Pin-Outs (2 of 3)

A4P2

PIN	SIGNAL	I/O	SOURCE/ DESTINATION	FUNCTION BLOCK
1 41	+5V DIG +5V DIG	IN IN	A11J6-8 A11J6-8	Q Q
2 42	GND DIG GND DIG	IN IN	A11J6-6 A11J6-6	Q Q
3 43	ID15 NC	I/O	ID15A3P1-3, A6P1-43, A11J7-2	B,K
4 44	ID14 NC	I/O	A3P1-3, A6P1-44, A11J7-9	B,K
5 45	ID13 NC	I/O	A3P1-5, A6P1-45, A11J7-12	B,K
6 46	ID12 NC	I/O	A3P1-6, A6P1-46, A11J7-11	B,K
7 47	ID11 NC	I/O	A3P1-7, A6P1-47, A11J7-14	B,E,K
8 48	ID10 NC	I/O	A3P1-8, A6P1-48, A11J7-13	B,E,K
9 49	ID9 NC	I/O	A3P1-9, A6P1-49, A11J7-16	B,E,K
10 50	ID8 NC	I/O	A3P1-10, A6P1-50, A11J7-15	B,E,K
11 51	ID7 NC	I/O	A3P1-11, A6P1-51, A11J1-11, A11J7-18	B,D,E,K,M
12 52	ID6 NC	I/O	A3P1-12, A6P1-52, A11J1-12, A11J7-17	B,D,E,K,M
13 53	ID5 NC	I/O	A3P1-13, A6P1-53, A11J1-9, A11J7-20	B,D,E,K,M
14 54	ID4 NC	I/O	A3P1-14, A6P1-54, A11J1-10, A11J7-19	B,D,E,K,M
15 55	ID3 L DR INT	I/O IN	A3P1-15, A6P1-55, A11J1-7, A11J7-22 A3P1-55	B,D,E,I,K,M,N
16 56	ID2 NC	I/O	A3P1-16, A6P1-56, A11J1-8, A11J7-21	B,D,E,I,K,M
17 57	ID1 NC	I/O	A3P1-17, A6P1-57, A11J1-5, A11J7-24	B,D,E,I,K,M
18 58	ID0 NC	I/O	A3P1-18, A6P1-58, A11J1-6, A11J7-23	B,D,E,I,K,M
19 59	IA7 IA7	IN IN	A3P1-60, A4P2-59, A6P1-59, A11J1-13 A3P1-60, A4P2-19, A6P1-59, A11J1-13	A A
20 60	NC IA6	IN	A3P1-20, A6P1-60, A11J1-16	A
21 61	IA5 IA8	IN IN	A3P1-21, A6P1-61, A11J1-15 A3P1-61, A6P1-20, A11J1-14	A A
22 62	IA4 L STTS TNT	IN OUT	A3P1-22, A6P1-62, A11J1-18 A3P1-56	A N
23 63	IA3 NC	IN	A3P1-23, A6P1-63, A11J1-17	A

\*Multiple destinations, refer to wiring schematic.

Table 8-19. A4 Pin-Outs (3 of 3)

A4P2

PIN	SIGNAL	I/O	SOURCE/ DESTINATION	FUNCTION BLOCK
24 64	IA2 NC	IN	A3P1-24, A6P1-64, A11J1-20	A,D,I,K
25 65	IA1 NC	IN	A3P1-25, A6P1-65, A11J1-19	A,D,I,K
26 66	GND DIG SH NC		A4P2-28, A4P2-30*	Q
27 67	L IOS NC	IN	A3P1-27, A6P1-67, A11J1-21	A
28 68	GND DIG SH NC		A4P2-26, A4P2-30*	Q
29 69	L WRITE NC	IN	A3P1-29, A6P1-69	A
30 70	GND DIG SH NC		A4P2-26, A4P2-28*	Q
31 71	L RESET NC	IN	A3P1-31, A6P1-71, A11J1-23	B
32 72	NC NC			
33 73	NC NC			
34 74	L LOG TEMP NC	OUT	A7P1-14, A8P1-14, A9P1-14, A10P9-14	B
35 75	L LOG ZERO NC	OUT	A7P1-15, A8P1-15, A9P1-15, A10P1-15	B
36 76	NC NC			
37 77	ADO SHIELD NC	OUT	A11J8-59	E
38 78	AUX DAC OUT STOP SWEEP	OUT OUT	A11J1-60 A11J8-47	E C
39 79	NC SWP RTN	IN	A11J8-49	F
40 80	PZAB SWEEP IN	IN IN	A11J8-48 A11J8-50	O F

\*Multiple destinations, refer to wiring schematic.



**Replaceable Parts List for A4 Assembly (1 of 3)**

Reference Designation	HP Part Number	Qty	Description	Mfr Code	Mfr Part Number
A4	08757-60004	1	BOARD ASSY-ADC	28480	08757-60004
A4C1	0180-3713	1	CAP-FXD 2.2uF ±10% 25 V TA	04200	173D225X9025V
A4C2	0160-4807	1	CAP-FXD 33pF ±5% 100 V CER COG	02010	SA102A330JAAH
A4C3	0160-4835	1	CAP-FXD 0.1uF ±10% 50 V CER X7R	02010	SA105C104KAAH
A4C4 - C8	0160-4682	5	CAP-FXD 1000pF ±2.5% 160 V POLYP-FL	06121	B33062-A1102-H
A4C9-C10	0160-4831	1	CAP-FXD 4700pF ±10% 100 V CER X7R	02010	SA101C472KAAH
A4C11	0160-4832	1	CAP-FXD 0.01uF ±10% 100 V CER X7R	02010	SA101C103KAAH
A4C12	0180-4135	1	CAP-FXD 33uF ±10% 10 V TA	04200	173D336X9010X
A4C13-C17	0180-4132	1	CAP-FXD 6.8uF ±10% 35 V TA	04200	173D685X9035X
A4C18	0160-4830	1	CAP-FXD 2200pF ±10% 100 V CER X7R	02010	SA101C222KAAH
A4C19-C20	0160-4812	1	CAP-FXD 220pF ±5% 100 V CER COG	02010	SA101A221JAAH
A4C21-C22	0160-4808	1	CAP-FXD 470pF ±5% 100 V CER COG	02010	SA101A471JAAH
A4C23	0160-4801	1	CAP-FXD 100pF ±5% 100 V CER COG	02010	SA102A101JAAH
A4C24	0180-4129	1	CAP-FXD 1uF ±10% 35 V TA	04200	173D105X9035V
A4C25	0160-4832	1	CAP-FXD 0.01uF ±10% 100 V CER X7R	02010	SA101C103KAAH
A4C26	0180-4135	1	CAP-FXD 33uF ±10% 10 V TA	04200	173D336X9010X
A4C27	0180-4129	1	CAP-FXD 1uF ±10% 35 V TA	04200	173D105X9035V
A4C28-C38	0180-4135	11	CAP-FXD 33uF ±10% 10 V TA	04200	173D336X9010X
A4C39	0160-4812	1	CAP-FXD 220pF ±5% 100 V CER COG	02010	SA101A221JAAH
A4C40 - C55	0160-5301	16	CAP-FXD 0.047uF ±20% 50 V CER X7R	02010	MD015C473MABH
A4CR1 - CR12	1901-0050	12	DIODE-SWITCHING 80V 200MA 2NS DO-35	03406	
A4CR13 - CR15	1901-0743	3	DIODE-PWR RECT 1N4004 400V 1A DO-41	04504	1N4004
A4CR17 - CR20	1901-0050	4	DIODE-SWITCHING 80V 200MA 2NS DO-35	03406	
A4CR21	1901-0539	1	DIODE-SCHOTTKY SM SIG	02062	50825510
A4CR22	1901-0050	1	DIODE-SWITCHING 80V 200MA 2NS DO-35	03406	
A4CR23	1901-0539	1	DIODE-SCHOTTKY SM SIG	02062	50825510
A4CR26 - CR30	1901-0050	3	DIODE-SWITCHING 80V 200MA 2NS DO-35	03406	
A4L1 - L4	9100-2562	3	INDUCTOR RF-CH-MLD 100UH ±10%	03273	17S103K
A4L5	9100-1788	1	CORE-FERRITE CHOKE-WIDEBAND;IMP:>680	11212	LB2/2.5ZB
A4L6	9100-2552	1	INDUCTOR RF-CH-MLD 15UH ±10%	03273	17S152K
A4L7	9100-1788	1	CORE-FERRITE CHOKE-WIDEBAND;IMP:>680	11212	LB2/2.5ZB
A4MP2	4040-0752	2	EXTR-PC BD YEL POLYC .062-IN-BD-THKNS	10456	
A4MP3	1480-0073	2	PIN-ROLL .062-IN-DIA .25-IN-LG BE-CU	04559	99-012-062-0250
A4MP4	0403-0026	1	PLUG-HOLE BDR-HD FOR .19-D-HOLE NYL	01924	207-120241-03-0101
A4P1	1251-7906	1	CONN-POST TYPE .100-PIN-SPCG 36-CONT	01380	534204-3
A4P2	1251-7907	1	CONN-POST TYPE .100-PIN-SPCG 80-CONT	01380	534204-8
A4R1	0757-0280	1	RESISTOR 1K ±1% .125W TF TC=0±100	05524	
A4R2	0757-0442	1	RESISTOR 10K ±1% .125W TF TC=0±100	05524	
A4R3	0757-0394	1	RESISTOR 51.1 ±1% .125W TF TC=0±100	05524	
A4R4	0757-0442	1	RESISTOR 10K ±1% .125W TF TC=0±100	05524	
A4R5	0698-3438	1	RESISTOR 147 ±1% .125W TF TC=0±100	05524	
A4R6	2100-3350	1	RESISTOR-TRMR 200 10% TKF SIDE-ADJ 1-TRN	03744	3386X-Y46-201
A4R7	0698-6343	1	RESISTOR 9K ±0.1% .125W TF TC=0±25	05524	
A4R8	0757-0280	1	RESISTOR 1K ±1% .125W TF TC=0±100	05524	
A4R9-R10	0757-0442	1	RESISTOR 10K ±1% .125W TF TC=0±100	05524	
A4R11	0698-6360	1	RESISTOR 10K ±0.1% .125W TF TC=0±25	05524	
A4R13	0698-6361	1	RESISTOR 8K ±0.1% .125W TF TC=0±25	05524	
A4R14	0698-8608	1	RESISTOR 4.525K ±0.1% .125W TF TC=0±25	05524	
A4R15	0698-8061	1	RESISTOR 8.25K ±0.1% .125W TF TC=0±25	05524	
A4R16	0757-0442	1	RESISTOR 10K ±1% .125W TF TC=0±100	05524	
A4R17	0698-3156	1	RESISTOR 14.7K ±1% .125W TF TC=0±100	05524	

*Replaceable Parts List for A4 Assembly (2 of 3)*

Reference Designation	HP Part Number	Qty	Description	Mfr Code	Mfr Part Number
A4R18	0757-0442	1	RESISTOR 10K $\pm$ 1% .125W TF TC=0 $\pm$ 100	05524	
A4R19	0698-6362	1	RESISTOR 1K $\pm$ 0.1% .125W TF TC=0 $\pm$ 25	05524	
A4R20	0757-0442	1	RESISTOR 10K $\pm$ 1% .125W TF TC=0 $\pm$ 100	05524	
A4R21	0698-3156	1	RESISTOR 14.7K $\pm$ 1% .125W TF TC=0 $\pm$ 100	05524	
A4R22	0757-0442	1	RESISTOR 10K $\pm$ 1% .125W TF TC=0 $\pm$ 100	05524	
A4R23	0698-6362	1	RESISTOR 1K $\pm$ 0.1% .125W TF TC=0 $\pm$ 25	05524	
A4R24	0757-0442	1	RESISTOR 10K $\pm$ 1% .125W TF TC=0 $\pm$ 100	05524	
A4R25	0698-3156	1	RESISTOR 14.7K $\pm$ 1% .125W TF TC=0 $\pm$ 100	05524	
A4R26	0757-0442	1	RESISTOR 10K $\pm$ 1% .125W TF TC=0 $\pm$ 100	05524	
A4R27	0698-6362	1	RESISTOR 1K $\pm$ 0.1% .125W TF TC=0 $\pm$ 25	05524	
A4R28	0757-0442	1	RESISTOR 10K $\pm$ 1% .125W TF TC=0 $\pm$ 100	05524	
A4R29	0698-3156	1	RESISTOR 14.7K $\pm$ 1% .125W TF TC=0 $\pm$ 100	05524	
A4R30	0757-0442	1	RESISTOR 10K $\pm$ 1% .125W TF TC=0 $\pm$ 100	05524	
A4R31	0698-6362	1	RESISTOR 1K $\pm$ 0.1% .125W TF TC=0 $\pm$ 25	05524	
A4R32-R33	0698-5350	1	RESISTOR 2.613K $\pm$ 0.1% .125W TF TC=0 $\pm$ 25	05524	
A4R34	0698-6321	1	RESISTOR 9.9K $\pm$ 0.1% .125W TF TC=0 $\pm$ 25	05524	
A4R35	0757-0280	1	RESISTOR 1K $\pm$ 1% .125W TF TC=0 $\pm$ 100	05524	
A4R36	0757-0279	1	RESISTOR 3.16K $\pm$ 1% .125W TF TC=0 $\pm$ 100	05524	
A4R37	0757-0442	1	RESISTOR 10K $\pm$ 1% .125W TF TC=0 $\pm$ 100	05524	
A4R38	0757-0279	1	RESISTOR 3.16K $\pm$ 1% .125W TF TC=0 $\pm$ 100	05524	
A4R39	0757-0442	1	RESISTOR 10K $\pm$ 1% .125W TF TC=0 $\pm$ 100	05524	
A4R40	0698-6360	1	RESISTOR 10K $\pm$ 0.1% .125W TF TC=0 $\pm$ 25	05524	
A4R41	0698-6361	1	RESISTOR 8K $\pm$ 0.1% .125W TF TC=0 $\pm$ 25	05524	
A4R42	0698-6360	1	RESISTOR 10K $\pm$ 0.1% .125W TF TC=0 $\pm$ 25	05524	
A4R43	0698-6361	1	RESISTOR 8K $\pm$ 0.1% .125W TF TC=0 $\pm$ 25	05524	
A4R44	0757-0465	1	RESISTOR 100K $\pm$ 1% .125W TF TC=0 $\pm$ 100	05524	
A4R45	0757-0442	1	RESISTOR 10K $\pm$ 1% .125W TF TC=0 $\pm$ 100	05524	
A4R46	0698-6624	1	RESISTOR 2K $\pm$ 0.1% .125W TF TC=0 $\pm$ 25	05524	
A4R47	0698-6355	1	RESISTOR 400 $\pm$ 0.1% .125W TF TC=0 $\pm$ 25	05524	
A4R48	0698-0083	1	RESISTOR 1.96K $\pm$ 1% .125W TF TC=0 $\pm$ 100	05524	
A4R49	0757-0442	1	RESISTOR 10K $\pm$ 1% .125W TF TC=0 $\pm$ 100	05524	
A4R50	0683-6855	1	RESISTOR 6.8M $\pm$ 5% .25W CC TC=-900/+1100	01607	
A4R51	0757-0442	1	RESISTOR 10K $\pm$ 1% .125W TF TC=0 $\pm$ 100	05524	
A4R52 - R56	0698-6630	5	RESISTOR 20K $\pm$ 0.1% .125W TF TC=0 $\pm$ 25	05524	
A4R57	0698-6361	1	RESISTOR 8K $\pm$ 0.1% .125W TF TC=0 $\pm$ 25	05524	
A4R58	0757-0290	1	RESISTOR 6.19K $\pm$ 1% .125W TF TC=0 $\pm$ 100	05524	
A4R59	0698-8826	1	RESISTOR 825K $\pm$ 1% .125W TF TC=0 $\pm$ 100	05524	
A4R60	0698-3156	1	RESISTOR 14.7K $\pm$ 1% .125W TF TC=0 $\pm$ 100	05524	
A4R61	0699-0070	1	RESISTOR 3.16M $\pm$ 1% .125W TF TC=0 $\pm$ 100	06118	
A4R62	0757-0442	1	RESISTOR 10K $\pm$ 1% .125W TF TC=0 $\pm$ 100	05524	
A4R63	0699-0070	1	RESISTOR 3.16M $\pm$ 1% .125W TF TC=0 $\pm$ 100	06118	
A4R64 - R69	0757-0442	6	RESISTOR 10K $\pm$ 1% .125W TF TC=0 $\pm$ 100	05524	
A4R70	0698-3160	1	RESISTOR 31.6K $\pm$ 1% .125W TF TC=0 $\pm$ 100	05524	
A4R71	0757-0458	1	RESISTOR 51.1K $\pm$ 1% .125W TF TC=0 $\pm$ 100	05524	
A4R72	0757-0462	1	RESISTOR 75K $\pm$ 1% .125W TF TC=0 $\pm$ 100	05524	
A4R73	0698-3160	1	RESISTOR 31.6K $\pm$ 1% .125W TF TC=0 $\pm$ 100	05524	
A4R74	0698-3159	1	RESISTOR 26.1K $\pm$ 1% .125W TF TC=0 $\pm$ 100	05524	
A4R75	0698-3157	1	RESISTOR 19.6K $\pm$ 1% .125W TF TC=0 $\pm$ 100	05524	
A4R76 - R79	0757-0442	4	RESISTOR 10K $\pm$ 1% .125W TF TC=0 $\pm$ 100	05524	
A4R80	0757-0401	1	RESISTOR 100 $\pm$ 1% .125W TF TC=0 $\pm$ 100	05524	
A4R81	0757-0416	1	RESISTOR 511 $\pm$ 1% .125W TF TC=0 $\pm$ 100	05524	



**Replaceable Parts List for A4 Assembly (3 of 3)**

Reference Designation	HP Part Number	Qty	Description	Mfr Code	Mfr Part Number
A4R82	0757-0280	1	RESISTOR 1K ±1% .125W TF TC=0±100	05524	
A4R97	0757-0278	1	RESISTOR 1.78K ±1% .125W TF TC=0±100	05524	
A4R98	0757-0438	1	RESISTOR 5.11K ±1% .125W TF TC=0±100	05524	
A4R99	0757-0280	1	RESISTOR 1K ±1% .125W TF TC=0±100	05524	
A4TP1 - TP11	0360-0535	11	CONNECTOR-SGL CONT TML-TS-PT	13296	
A4U1	1826-0315	1	IC OP AMP GP QUAD 14 PIN DIP-P	03406	LM348N
A4U2	1826-0791	1	SAMPLE AND HOLD 8 -DIP-P	03406	LF398N
A4U3	1826-0961	1	IC OP AMP LOW-BIAS-H-IMP 8 PIN DIP-P	03406	LF411CN
A4U4	1826-0315	1	IC OP AMP GP QUAD 14 PIN DIP-P	03406	LM348N
A4U5	1813-0450	1	A/D 16-BIT 32-MOD BPLR	05436	2D1021
A4U6-U7	1820-1447	1	IC RGTR TTL/LS FILES	01698	SN74LS670N
A4U8	1820-1206	1	IC GATE TTL/LS NOR TPL 3-INP	01698	SN74LS27N
A4U9	1820-1199	1	IC INV TTL/LS HEX 1-INP	01698	SN74LS04N
A4U10	1820-1285	1	IC GATE TTL/LS AND-OR-INV 2-INP	01698	SN74LS54N
A4U11	1820-1437	1	IC MV TTL/LS MONOSTBL CLEAR DUAL	01698	SN74LS221N
A4U12	1826-0138	1	IC COMPARATOR GP QUAD 14 PIN DIP-P	03406	LM339N
A4U13	1826-0791	1	SAMPLE AND HOLD 8 -DIP-P	03406	LF398N
A4U14-U15	1826-0609	1	ANALOG MULTIPLEXER 8 CHNL 16 -CERDIP	02180	MUX-08FQ
A4U16	1826-0742	1	IC V RGLTR-V-REF-FXD 10V TO-5 PKG	03285	AD581J
A4U17-U18	1820-1447	1	IC RGTR TTL/LS FILES	01698	SN74LS670N
A4U19	1820-2024	1	IC DRVR TTL/LS BUS OCTL	01698	SN74LS244N
A4U20	1820-1112	1	IC FF TTL/LS D-TYPE POS-EDGE-TRIG	01698	SN74LS74AN
A4U21	1820-1208	1	IC GATE TTL/LS OR QUAD 2-INP	01698	SN74LS32N
A4U22-U23	1820-1112	1	IC FF TTL/LS D-TYPE POS-EDGE-TRIG	01698	SN74LS74AN
A4U24	1826-0138	1	IC COMPARATOR GP QUAD 14 PIN DIP-P	03406	LM339N
A4U25	1826-0961	1	IC OP AMP LOW-BIAS-H-IMP 8 PIN DIP-P	03406	LF411CN
A4U26-U27	1826-0791	1	SAMPLE AND HOLD 8 -DIP-P	03406	LF398N
A4U28	1810-0548	1	NETWORK-RES 16-DIP 10.0K OHM X 8	04568	698-3-R10KD
A4U29	1826-0315	1	IC OP AMP GP QUAD 14 PIN DIP-P	03406	LM348N
A4U30	1810-0548	1	NETWORK-RES 16-DIP 10.0K OHM X 8	04568	698-3-R10KD
A4U31	1826-0610	1	ANALOG MULTIPLEXER 4 CHNL 16 -CERDIP	02180	MUX-24FQ
A4U32	1826-0962	1	IC OP AMP LOW-BIAS-H-IMP DUAL 8 PIN	03406	LF412CN
A4U33	1820-1447	1	IC RGTR TTL/LS FILES	01698	SN74LS670N
A4U34	1826-1379	1	D/A 8-DGT 20-PLASTIC CMOS	03285	AD7226KN
A4U35	1826-1400	1	D/A 12-DGT 20-PLASTIC CMOS	03285	AD7545AKN
A4U36	1820-1730	1	IC FF TTL/LS D-TYPE POS-EDGE-TRIG COM	01698	SN74LS273N
A4U37-U38	1820-1730	1	IC FF TTL/LS D-TYPE POS-EDGE-TRIG COM	01698	SN74LS273N
A4U39	1820-1199	1	IC INV TTL/LS HEX 1-INP	01698	SN74LS04N
A4U40	1820-1216	1	IC DCDR TTL/LS BIN 3-TO-8-LINE 3-INP	01698	SN74LS138N
A4U41	1820-1193	1	IC CNTR TTL/LS BIN ASYNCHRO	01698	SN74LS197N
A4U42	1820-1437	1	IC MV TTL/LS MONOSTBL CLEAR DUAL	01698	SN74LS221N
A4U43	1826-0962	1	IC OP AMP LOW-BIAS-H-IMP DUAL 8 PIN	03406	LF412CN
A4U44	1826-0791	1	SAMPLE AND HOLD 8 -DIP-P	03406	LF398N
A4U45	1826-0600	1	IC OP AMP LOW-BIAS-H-IMP QUAD 14 PIN	01698	TL074ACN
A4U46	1826-0720	1	ANALOG SWITCH 4 SPST 16 -CERDIP	02180	SW-02FQ
A4U47	1826-0961	1	IC OP AMP LOW-BIAS-H-IMP 8 PIN DIP-P	03406	LF411CN
A4VR1	1902-0041	1	DIODE-ZNR 5.11V 5% DO-35 PD=.4W	02037	SZ30016-9
A4VR2	1902-0049	1	DIODE-ZNR 6.19V 5% DO-35 PD=.4W	02037	SZ30016-122RL

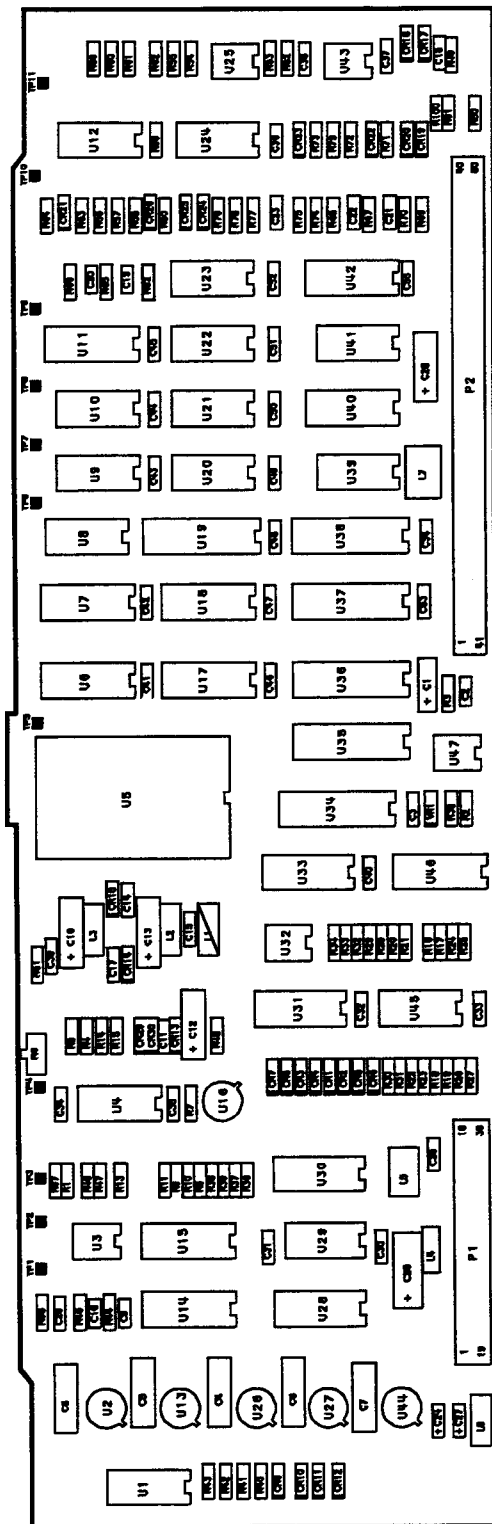
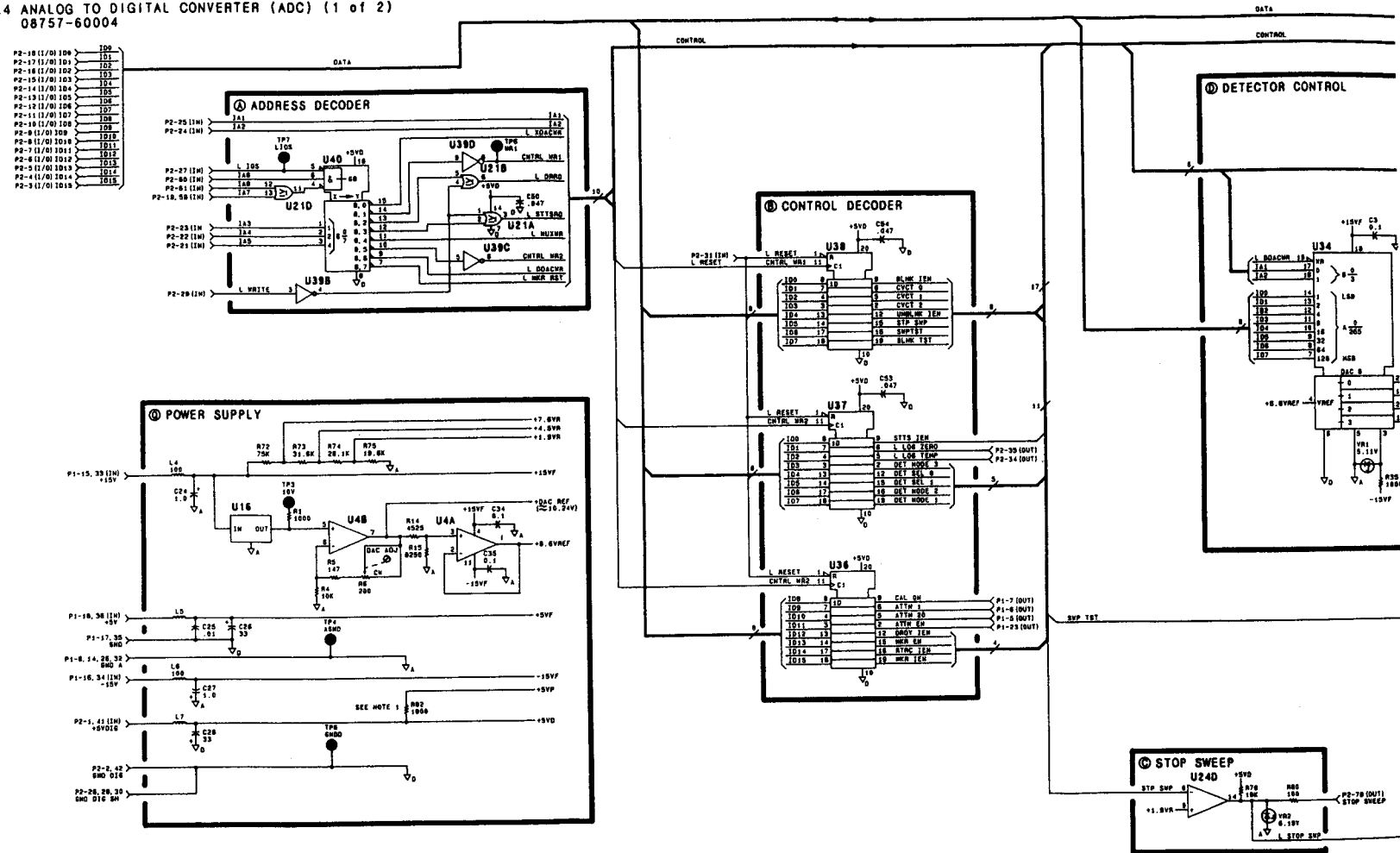
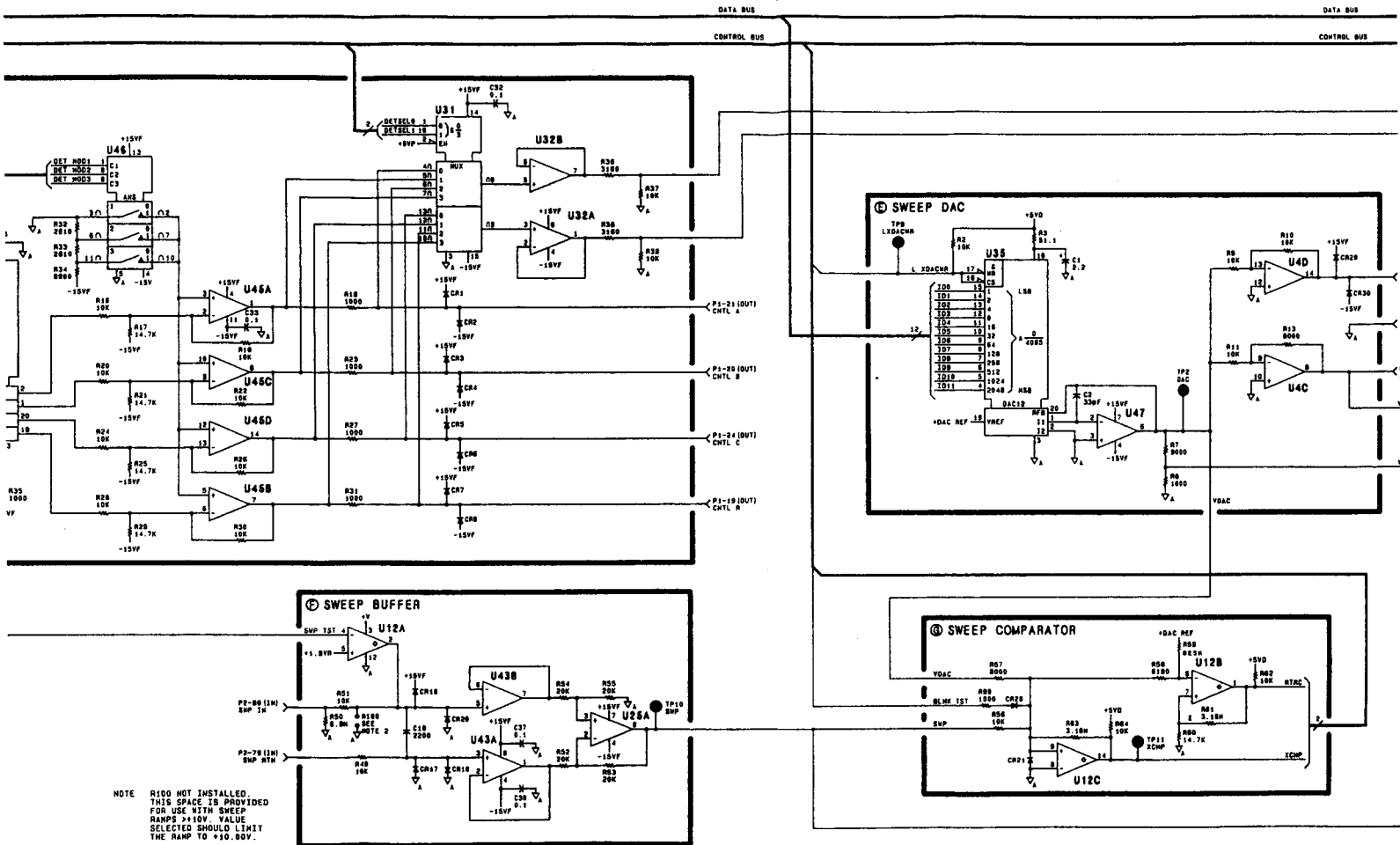


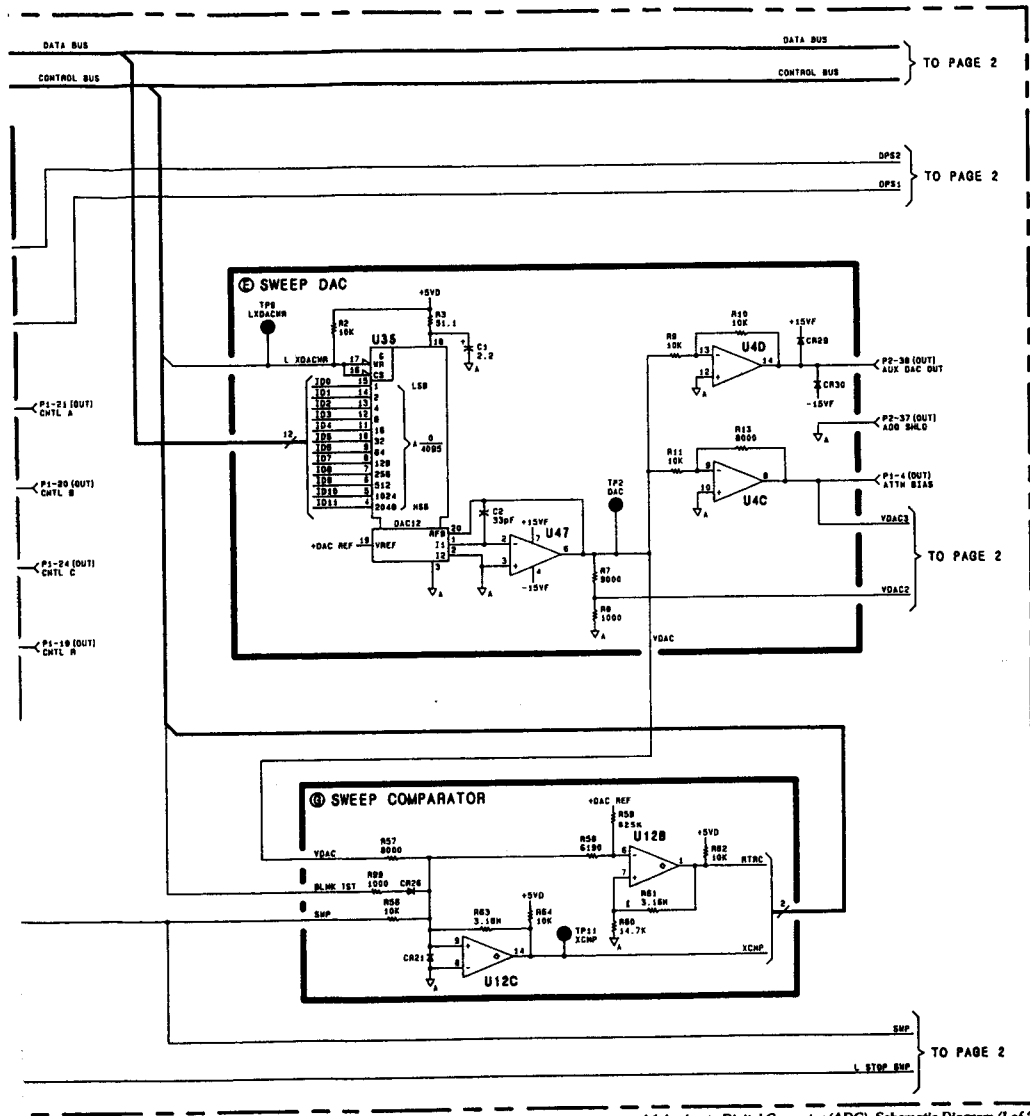
Figure 8-23. A4 Component Locations Diagram

4 ANALOG TO DIGITAL CONVERTER (ADC) (1 of 2)  
08757-60004





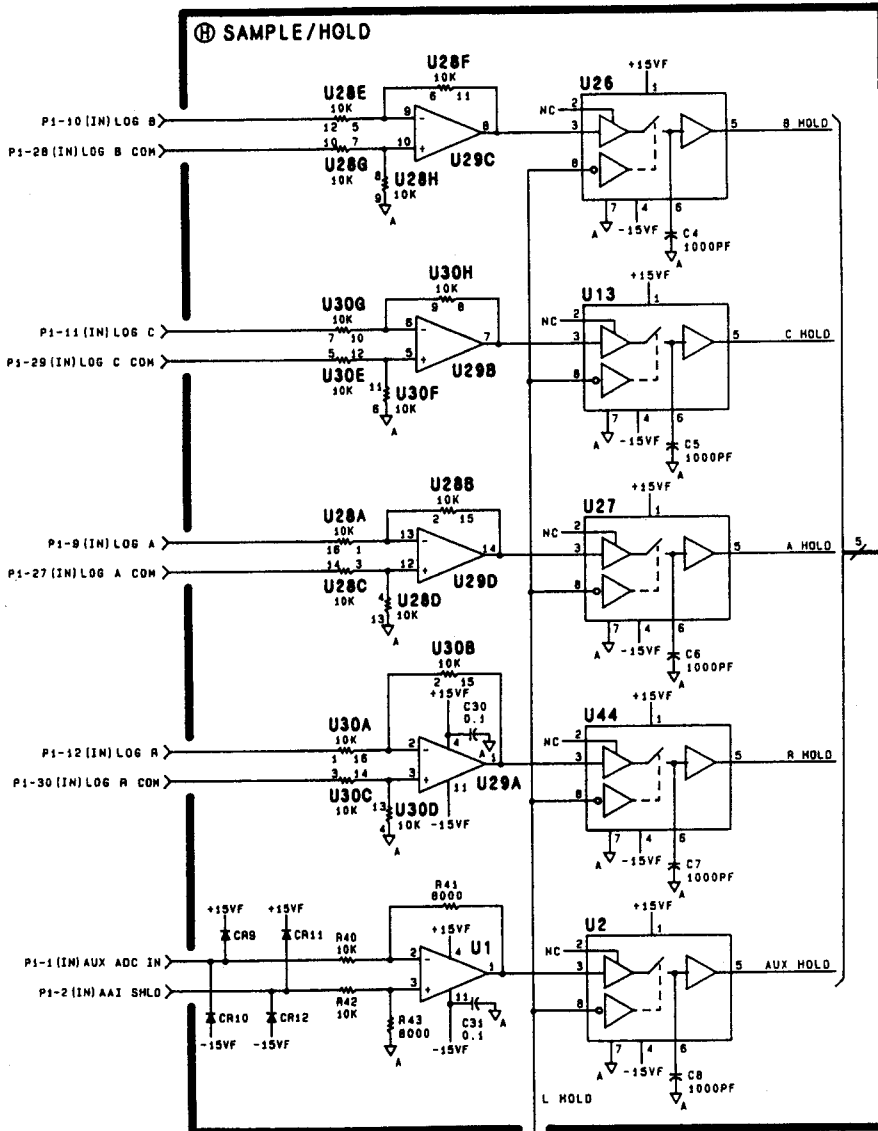
L 81P-1

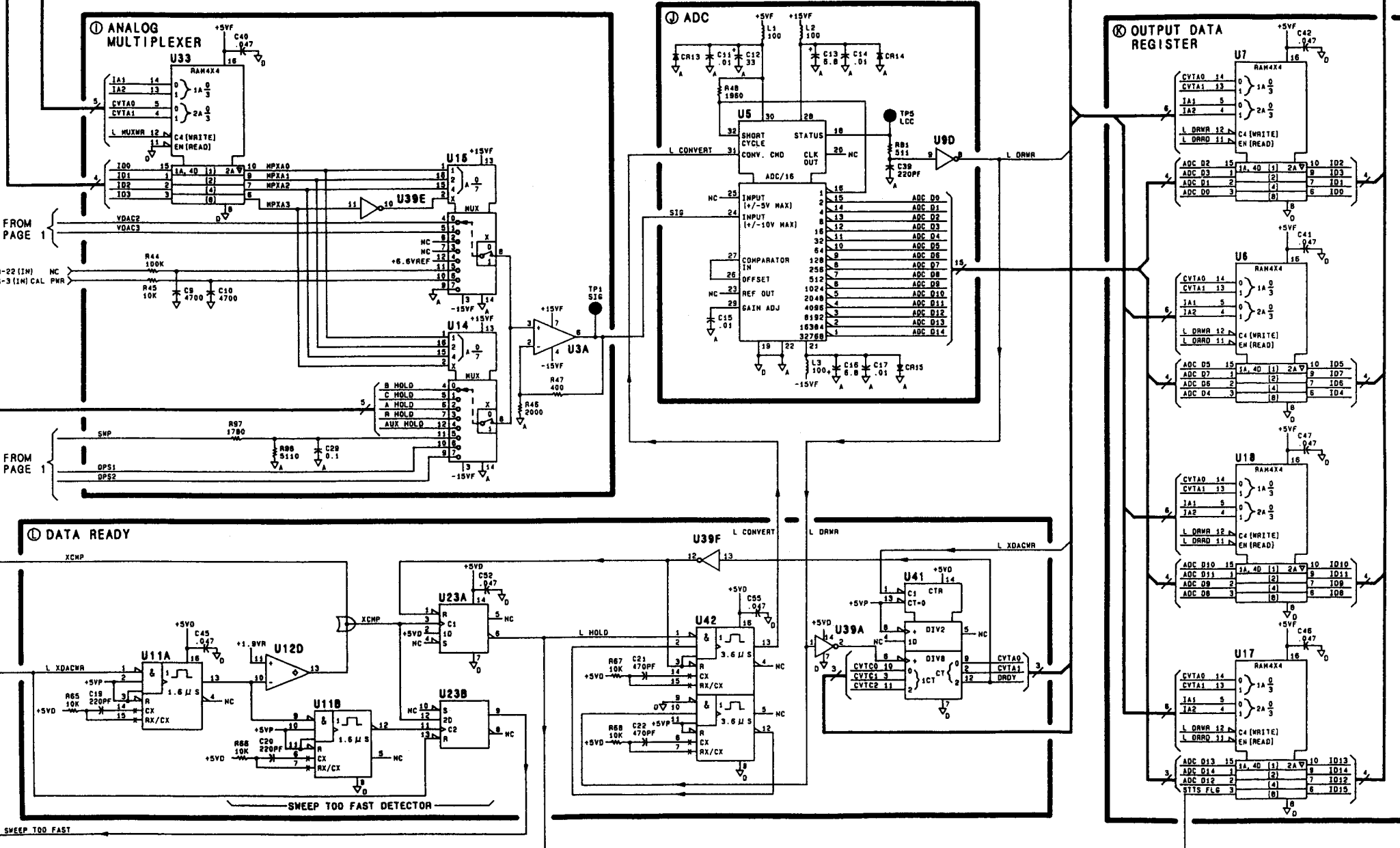


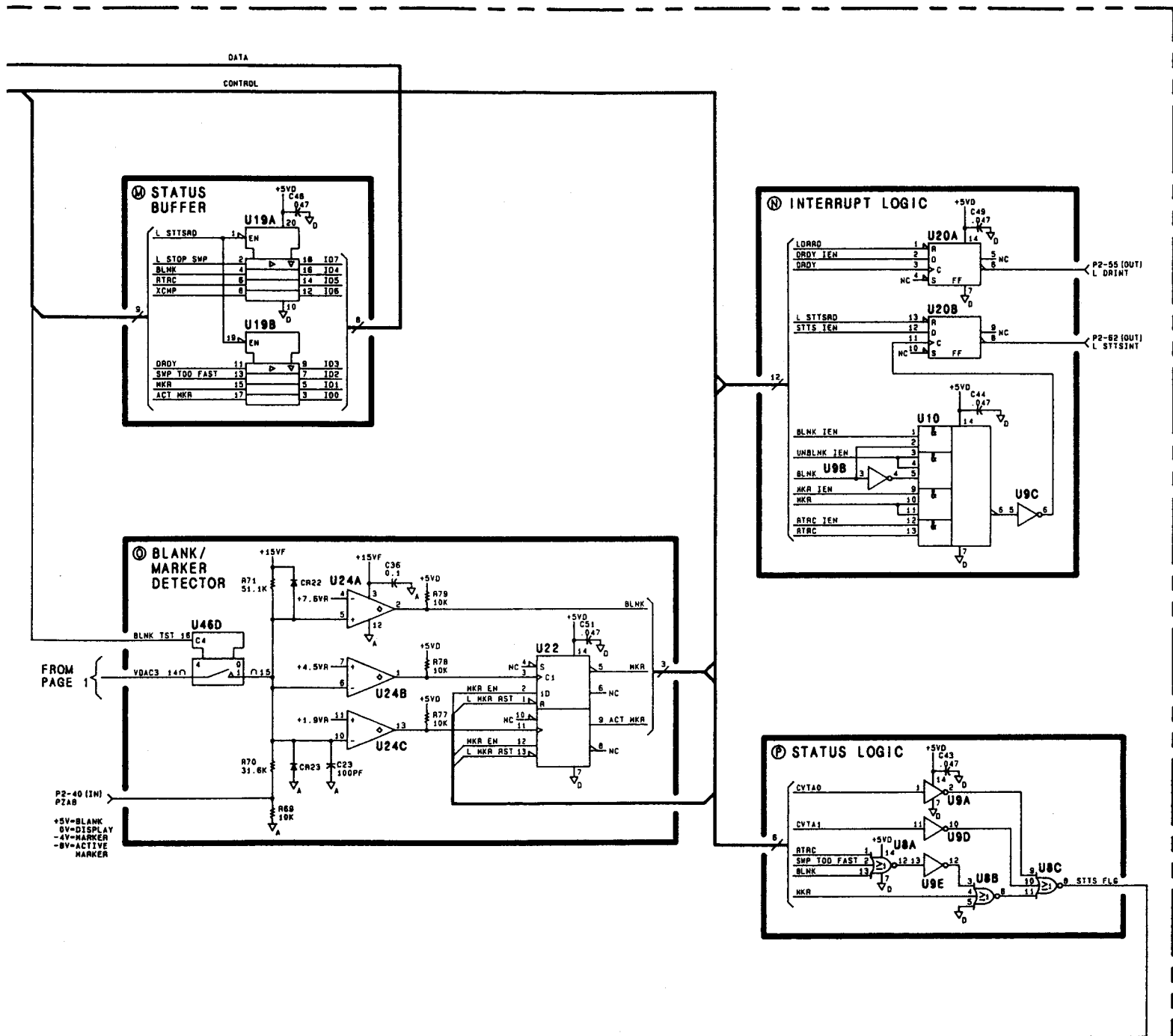
A4 Analog to Digital Converter (ADC), Schematic Diagram (1 of 2)

A4 ANALOG TO DIGITAL CONVERTER (ADC) (2 OF 2)  
08757-60004

FROM DATA  
PAGE 1 CONTROL









## **A5 Modulator Driver Standard Instrument Only**

### **CIRCUIT DESCRIPTION**

The A5 modulator driver supplies a 27.778 kHz symmetrical square wave drive to modulate the microwave source. This drive can be used for external stand-alone microwave modulators, or can be applied to the amplitude modulation or pulse modulation inputs of compatible microwave sources. (If the source has an accurate 27.778 kHz  $\pm 20$  Hz internal square wave modulation, no additional connections are needed.)

#### **A. OSCILLATOR/DRIVER**

The oscillator driver produces a 27.778 kHz signal for the output driver. The 27.778 kHz signal is obtained from a 444.444 kHz crystal oscillator Y1 that is divided by 16. The frequency accuracy of Y1 is better than  $\pm 0.05\%$ . U1 contains both the oscillator circuitry and the divide-by-16 circuitry. The output is enabled by a logic zero at U1 pin 12. The ripple counter technique ensures that the divided output signal at pin 7 has perfect symmetry. The output at TP2 is a 0 V to 5 V square wave at 27.778 kHz.

The low-pass filter formed by C2, L1, and C3 shapes the 27.778 kHz signal to control the rise and fall times of the square wave.

#### **B. AMPLIFIER/BUFFER**

U2 is an inverting amplifier with a gain of  $-2.4$ . This converts the 0 to 5 V square wave signal from the oscillator/driver to a 12 V p-p signal. The voltage divider formed by R9 and R10 offsets this by +6 volts so that the output of U2 is centered about 0 volts. Current gain is provided by Q3 and Q5. Constant current source Q1, together with CR1 through CR4, biases Q5 to prevent crossover distortion. (There is no Q2 or Q4.) The  $\pm 6$  V output from U2 is current limited by a series 75 ohm resistor located on the A13 rear panel assembly. Therefore, the rear-panel output provides a  $\pm 2.4$  V signal into 50 ohms.

The output at J1 runs to the A13 rear panel assembly and from there to the rear panel MODULATOR BNC connector via coaxial cable A13W2. The return shields of both the BNC connector and the cable are floating from chassis ground, connected to instrument ground by 511 ohms. The shield is usually connected to ground at the microwave modulator or source, when connected. The shield should not contact ground anywhere else or ground loops will result and may reduce the dynamic range of the analyzer. A 5 V zener diode on the A13 assembly connects the floating return line to chassis ground directly at the BNC output to minimize electrostatic discharge (ESD) effects. The power supply filtering for the modulator driver is capacitively coupled directly to this return line. When modulation is turned off, the output is at its high state (+6 volts), turning an external modulator to its low loss state.

#### **C. POWER SUPPLIES**

LC filtering reduces noise on the power supply lines. Additional local filtering keeps unwanted 27.778 kHz noise from getting back to the rest of the instrument.

# A5 Troubleshooting

## Standard Instrument Only

### BASIC CHECKS

Verify the power supply voltages on the A5 modulator driver assembly.

Check the modulator drive cable A13W2 between the A13 rear panel assembly and the A5 assembly.

Modulation can be turned on and off via the HP interface bus. Modulation can also be turned on or off by the A3 CPU, depending on whether or not a source is connected to the 8757 system interface, and whether AC or DC detection mode is selected. Make sure the instrument is in local operating mode for troubleshooting.

When using DC detection mode, turn off the internal modulation of the source. Normally, when the 8757 system interface is used, the analyzer in DC mode automatically turns off the internal modulation of the source. However, this feature is overridden if the modulation control key of the source is pressed. This enables both internal modulation and DC detection at the same time, resulting in a trace that alternates from a high level trace to a noise floor trace. This cycle may repeat several times per second, depending on the beat frequency produced by two separate 27.778 kHz oscillators.

### MODULATION ON/OFF CONTROL

Check for a logic 0 at TP1 (L MOD ON) with modulation on. To turn on the modulation, press **SYSTEM** **MORE MOD ON/OFF**. If TP1 does not go low, trace the problem back to the A3 CPU assembly (especially the address decoder). If TP1 does go low, but the oscillator at TP2 does not work, suspect U1 or Y1.

### FREQUENCY

There is no adjustment for frequency. If the modulation can be controlled, but is slightly off frequency, replace crystal Y1. If the modulation frequency is extremely inaccurate, the problem is probably with the divide-by-16 circuitry in U1, so U1 should be replaced.

### AMPLIFIER/BUFFER

Verify that U2 pins 2 and 3 are at +1.8 V. Verify about -9 V at the emitter of Q1.

If the positive half of the square wave is distorted or missing, suspect Q3 or CR5. If the negative half of the square wave is distorted or missing, suspect Q5, CR6, or Q1.

## **A5 CAL/MOD Board Assembly Option 002 Only**

### **CIRCUIT DESCRIPTION**

The A5 Cal/Mod board used in the option 002 instrument provides all of the functions of the standard A5 board in addition to providing a 50 MHz reference output that is controllable from +20dBm to below -55 dBm. Correction factors for this board are stored in the EEPROMs on the A3 assembly. Because of this, replacing either board will require the use of special calibration software and equipment to regenerate these cal constants.

The sheer complexity of this board required the use of surface-mount components. Because of this, repair of this board is NOT recommended! Instead, an exchange board assembly has been set up as an alternative. The troubleshooting hints that follow are useful only in isolating the fault to the board level. Remember that if the board is replaced, it must be recalibrated after it has been installed.

### **Troubleshooting modulation problems**

The 27.778 kHz modulation driver circuit is very similar to that on the standard A5 board. The major exception is that the crystal is 222.222 kHz and is then divided by 8 to produce 27.778 kHz. Verify that 222kHz is always seen on TP11 and that 27.778 kHz is only seen TP14 when the modulation is turned on. Output characteristics are similar to the standard A5 board:  $\pm 6V$  into an open circuit, and  $\pm 2.4V$  into 50 ohms.

### **Troubleshooting the 50MHz calibrator**

First verify all power supplies to the board and verify that TP9 is within 0.5 volts of -10 volts.

If the option 002 test software program (and equipment) is available, run the program to help determine the condition of the board. If the program will not run because of a major fault in the board, the board will have to be replaced. This assumes all inputs to the board are correct.

If the board is simply in need of calibration this can then be performed using the option 002 program. If the program determines the board is too far from nominal, the board will have to be replaced.

If the option 002 program or test equipment is not available, a functional test can be performed by connecting a power meter to the Power Cal output and manually setting the calibrator output power to a few known values. Verify the power meter reads similarly. This test will not test to within specification but will provide a high degree of confidence that the board is functioning correctly. Make sure several power levels are chosen; some above 0 dB and some below 0dBm. Avoid measurements near the limits of the power sensor. See performance tests for this procedure.

Table 8-20. A5 Pin-Outs

PIN	SIGNAL	I/O	SOURCE/ DESTINATION	FUNCTION BLOCK
1-3 1-21	NC NC			
4* 22*	ATTN BIAS CAL PWR	IN OUT	A4J1-4 A4J1-3	
5* 23*	ATTN 20 ATTN EN	IN IN	A4J1-5 A4J1-23	
6-8 24*	NC ATTN 1	IN	A4J1-6	
9 25*	GND PLANE CAL ON	IN IN	A11J6-4 A4J1-7	C C
10 26	GND PLANE NC	IN	A11J6-4	C
11 27	GND PLANE GND PLANE	IN IN	A11J6-4 A11J6-4	C C
12 28	GND PLANE GND PLANE	IN IN	A11J6-4 A11J6-4	C C
13 29	NC GND PLANE	IN	A11J6-4	
14* 30	CAL OSC EN GND PLANE	IN	A3J1-76 A11J6-4	A
15 31*	+15V CAL MOD EN	IN	A11J6-14 A3J1-32	C
16 32	-15V L 27K MOD DR	IN IN	A11J6-13 A3P1-75	C C
17 33	GND PLANE +15V	IN IN	A11J6-4 A11J6-14	C C
18 34	+5V -15V	IN IN	A11J6-11 A11J6-13	C C
35	GND PLANE	IN	A11J6-4	
36	+5V	IN	A11J6-11	

\*Option 002 only.

*Replaceable Parts List for A5 Assembly (1 of 1)*

Reference Designation	HP Part Number	Qty	Description	Mfr Code	Mfr Part Number
A5	08757-60111	1	MOD/CAL - 8757D OPT.002 ONLY NOT REPAIRABLE - ORDER EXCHANGE ASSEMBLY 08757-69111		
A5	08757-60005	1	BD AY-MODULATOR - STANDARD ONLY	28480	08757-60005
A5C1	0160-4791	1	CAP-FXD 10pF ±5% 100 V CER C0G	02010	SA102A100JAAH
A5C2	0160-4806	1	CAP-FXD 39pF ±5% 100 V CER C0G	02010	SA102A390JAAH
A5C3	0160-4810	1	CAP-FXD 330pF ±5% 100 V CER C0G	02010	SA101A331JAAH
A5C4	0160-4814	1	CAP-FXD 150pF ±5% 100 V CER C0G	02010	SA101A151JAAH
A5C5-C9	0160-4832	1	CAP-FXD 0.01uF ±10% 100 V CER X7R	02010	SA101C103KAAH
A5C10	0180-4170	1	CAP-FXD 22uF ±10% 35 V TA	12340	T322E226K035AS
A5C11	0160-4832	1	CAP-FXD 0.01uF ±10% 100 V CER X7R	02010	SA101C103KAAH
A5C12	0180-4170	1	CAP-FXD 22uF ±10% 35 V TA	12340	T322E226K035AS
A5C13	0160-4832	1	CAP-FXD 0.01uF ±10% 100 V CER X7R	02010	SA101C103KAAH
A5C14	0180-4135	1	CAP-FXD 33uF ±10% 10 V TA	04200	173D336X9010X
A5C15	0160-4832	1	CAP-FXD 0.01uF ±10% 100 V CER X7R	02010	SA101C103KAAH
A5C16-C17	0160-4835	1	CAP-FXD 0.1uF ±10% 50 V CER X7R	02010	SA105C104KAAH
A5CR1 - CR6	1901-0050	6	DIODE-SWITCHING 80V 200MA 2NS DO-35	03406	
A5J1	1250-0543	1	CONNECTOR-RF SMB PLUG PC-W/O-STDF 50-OHM	05769	51-053-0349-BE8
ASL1	9100-2578	1	INDUCTOR RF-CH-MLD 2.7MH ±10%	03273	17S274K
ASL2-L3	9100-2555	1	INDUCTOR RF-CH-MLD 27UH ±10%	03273	17S272K
ASL4	9100-2562	1	INDUCTOR RF-CH-MLD 100UH ±10%	03273	17S103K
ASMP2-MP3	4040-0753	2	EXTR-PC BD GRN POLYC .062-IN-BD-THKNS	10456	
A5MP4	1205-0011	1	HEAT SINK TO-5/TO-39-CS	05792	TXBF-032-025B
A5P1	1251-7906	1	CONN-POST TYPE .100-PIN-SPCG 36-CONT	01380	534204-3
A5Q1	1854-0477	1	TRANSISTOR NPN 2N2222A SI TO-18 PD=500MW	02037	2N2222A
A5Q3	1854-0637	1	TRANSISTOR NPN 2N2219A SI TO-5 PD=800MW	02037	2N2219A
A5Q5	1853-0314	1	TRANSISTOR PNP 2N2905A SI TO-39 PD=400MW	02037	2N2905A
A5R1-R2	0698-3449	1	RESISTOR 28.7K ±1% .125W TF TC=0±100	05524	
A5R3	0698-3266	1	RESISTOR 237K ±1% .125W TF TC=0±100	05524	
A5R4	0757-0444	1	RESISTOR 12.1K ±1% .125W TF TC=0±100	05524	
A5R5	0698-0085	1	RESISTOR 2.61K ±1% .125W TF TC=0±100	05524	
A5R6-r7	0698-3155	1	RESISTOR 4.64K ±1% .125W TF TC=0±100	05524	
A5R8	0699-0768	1	RESISTOR 22.6K ±0.1% .125W TF TC=0±25	01074	
A5R9	0698-3155	1	RESISTOR 4.64K ±1% .125W TF TC=0±100	05524	
A5R10-R11	0698-0085	1	RESISTOR 2.61K ±1% .125W TF TC=0±100	05524	
A5R12	0698-3156	1	RESISTOR 14.7K ±1% .125W TF TC=0±100	05524	
A5R13	0757-0444	1	RESISTOR 12.1K ±1% .125W TF TC=0±100	05524	
A5R14	0698-0085	1	RESISTOR 2.61K ±1% .125W TF TC=0±100	05524	
A5R15-R16	0757-0706	1	RESISTOR 51.1 ±1% .25W TF TC=0±100	05524	
A5R17-R18	0757-0416	1	RESISTOR 511 ±1% .125W TF TC=0±100	05524	
A5R19-R20	0757-0401	1	RESISTOR 100 ±1% .125W TF TC=0±100	05524	
A5R21	0698-0085	1	RESISTOR 2.61K ±1% .125W TF TC=0±100	05524	
A5R22	0757-0416	1	RESISTOR 511 ±1% .125W TF TC=0±100	05524	
A5TP1 - TP4	0360-0535	4	CONNECTOR-SGL CONT TML-TS-PT	13296	
A5U1	1820-3200	1	IC CNTR CMOS/HC BIN ASYNCHRO	02037	MC74HC4060N
A5U2	1826-0081	1	IC OP AMP WB 8 PIN TO-99	03406	LM318H
A5Y1	0410-1561	1	CRYSTAL-QUARTZ 444.44 KHZ	11113	CX-1H 444.44 KHZ (A)

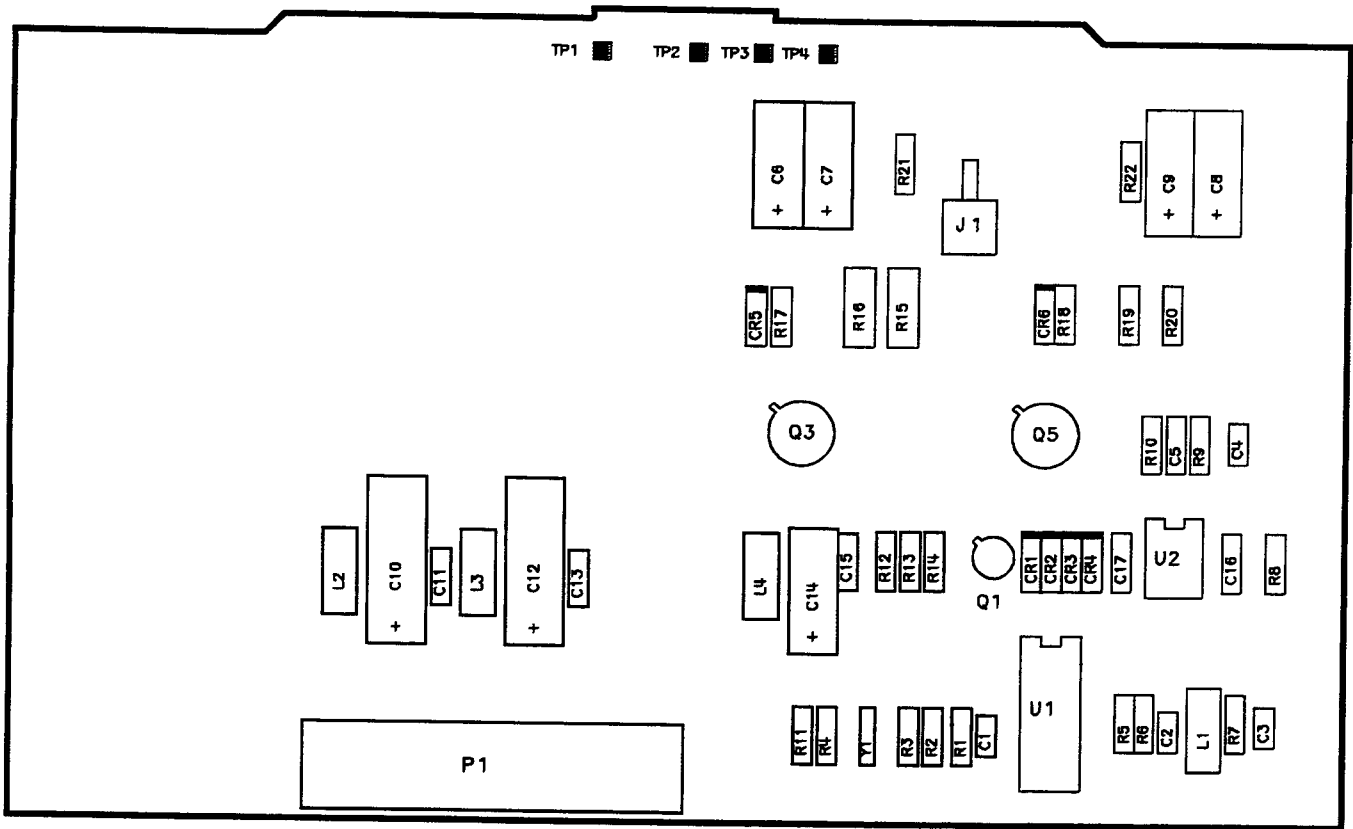


Figure 8-25. A5 Component Locations Diagram (Standard Only)

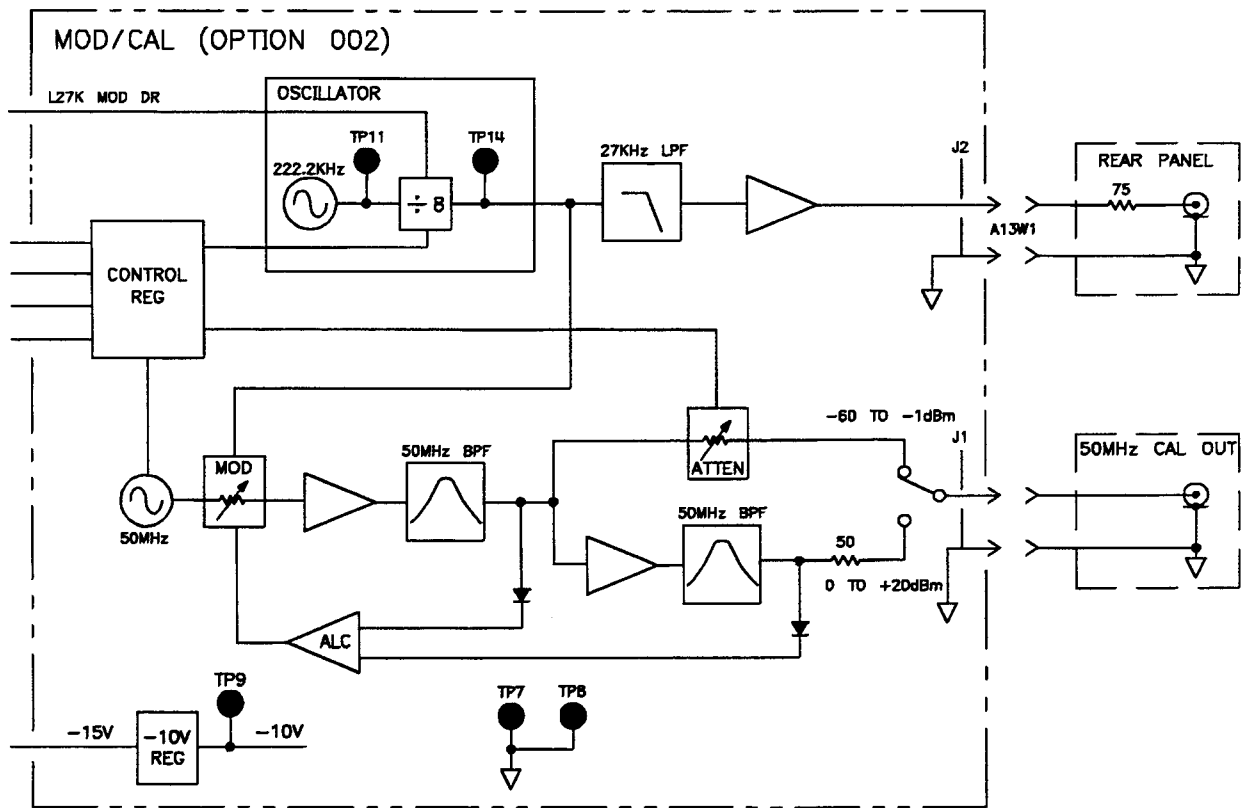


Figure 8-26. A5 Mod/Cal Block Diagram (option 002 only)

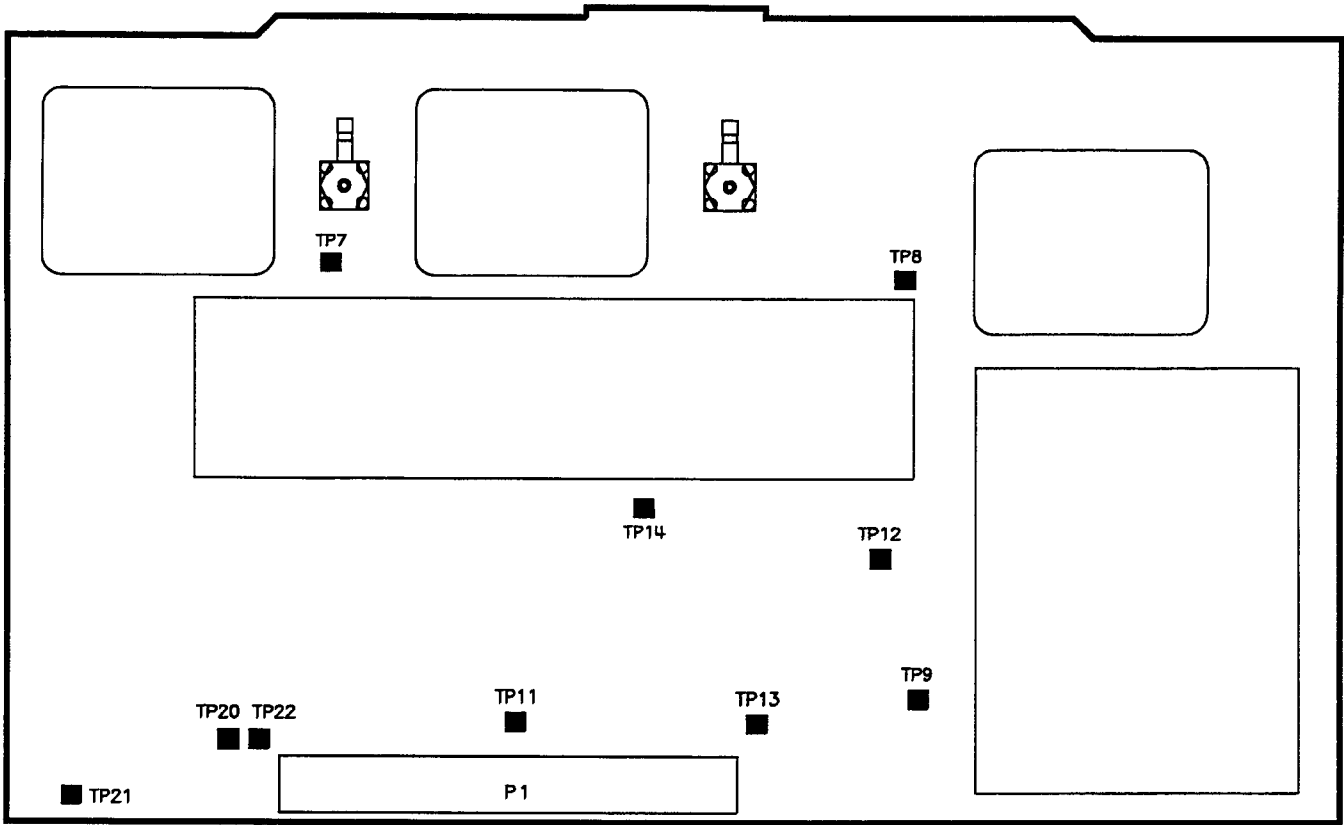
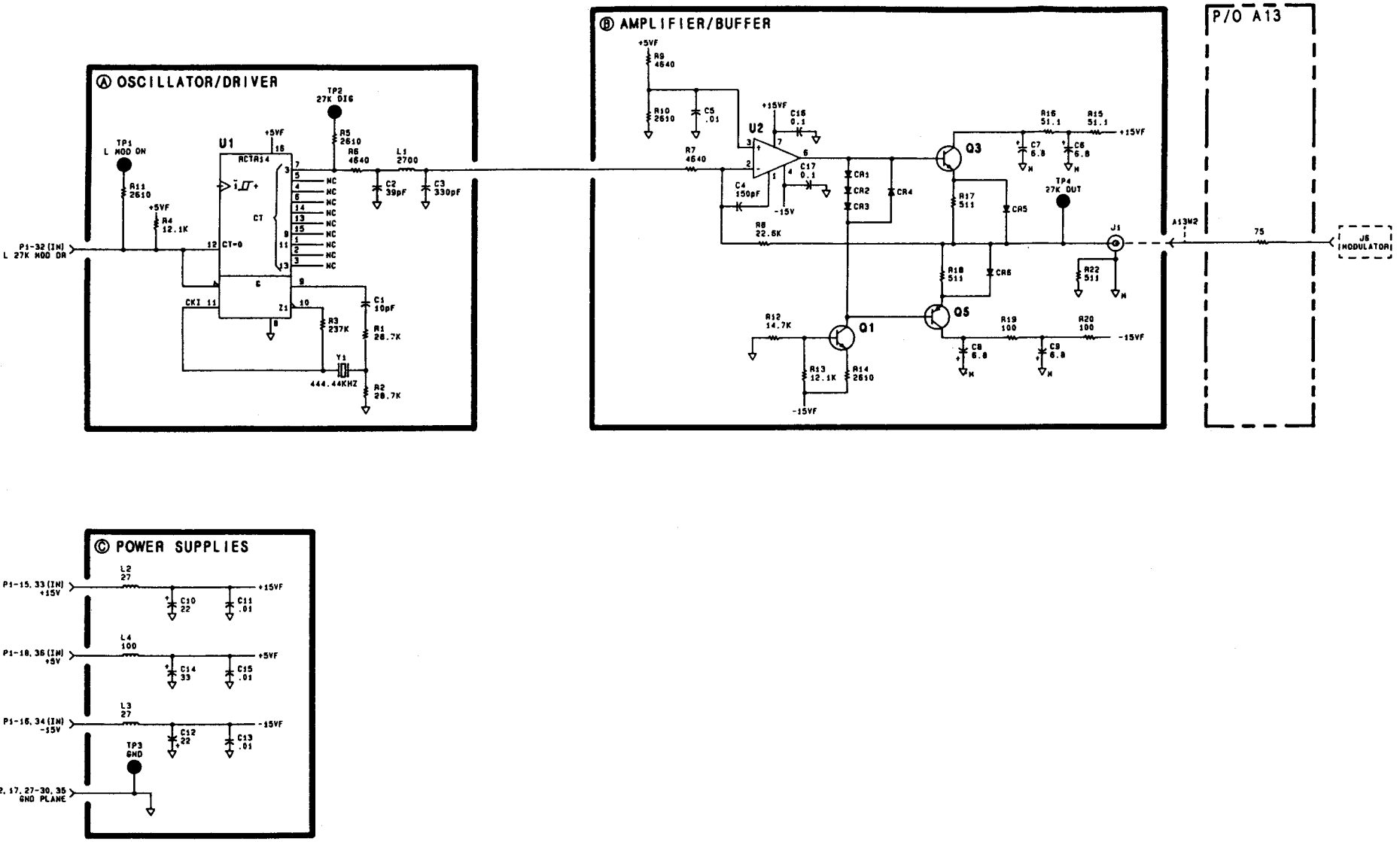


Figure 8-27. A5 Option 002 Test Point Location Diagram



A5 MODULATOR DRIVER (STANDARD ONLY)  
08757-60005



## A6 HP–IB Assembly

### CIRCUIT DESCRIPTION

The A6 HP–IB assembly provides HP–IB ports for the analyzer to communicate with other external instruments or controllers. HP–IB is Hewlett–Packard’s hardware, software, documentation, and support for IEEE–488 and IEC–625 worldwide standards for interfacing instruments.

IEEE–488 carefully defines an instrumentation interface to simplify the integration of up to fifteen instruments or controllers into systems. Data transfer occurs asynchronously in eight–bit parallel, byte–serial fashion. IEEE–488 employs a sixteen line interconnect bus. Eight data lines are used to transmit address and data information, using ASCII code. Five control lines manage all communication on the bus. Three handshake lines control the timing of data transfer using a three–wire interlocked handshake technique.

The HP 8757D has two HP–IB ports. Although the two ports are electrically identical, they are not interchangeable. The HP INTERFACE BUS enables remote control of the analyzer by an external controller; the 8757 SYSTEM INTERFACE allows the analyzer itself to control a compatible source, plotter, printer, or disk drive.

The HP INTERFACE BUS is the general purpose HP–IB port, and is normally connected to an external controller (such as a calculator or desktop computer). The controller then remotely controls the analyzer. Other instruments can also be connected to the HP INTERFACE BUS port, but they must be set to addresses different from the analyzer address. These instruments are then controlled by the external controller: the analyzer will not control this bus.

The 8757 SYSTEM INTERFACE, however, is controlled by the A3 CPU within the analyzer to communicate with selected compatible microwave sources, plotters, or printers. External controllers and other non–compatible instruments must not be attached to the 8757 SYSTEM INTERFACE port. However, it is possible to send commands from an external controller via the HP interface bus for the analyzer to pass through to instruments attached to the 8757 system interface.

In addition to the HP–IB circuits, a self–test latch is also located on this assembly to verify the proper reading and writing of the sixteen data lines from the A3 CPU assembly. This self–test is exercised during the instrument bus test, which is also performed during preset.

#### A. ADDRESS DECODER

The address decoder directs the flow of data on the instrument bus between the A3 CPU and A6 HP–IB assemblies.

The A3 CPU reads from and writes to the two HP–IB ports via the instrument bus. The address decoder decodes the instrument bus address lines to select either the HP instrument bus or the 8757 system interface to send or receive the information on the data lines. Three–to–eight decoder U4 decodes address lines IA4, IA5, and IA6 to select L AIB, L BIB, L BLR, or L BLW to pulse low. L IOS controls the timing.

L AIB and L BIB are connected to the HP–IB transceiver U2 and the 8757 system interface transceiver U1, respectively. These lines are used to select one of the two ports. Address lines IA1, IA2, and IA3 are connected to both U1 and U2. These address lines select one of eight internal registers when L AIB and L BIB select one of the two ports.

Refer to Table 8–22 for the addresses to activate the L AIB and L BIB outputs, and descriptions of the functions they perform.

## B. HP INTERFACE BUS

The HP interface bus transceiver provides the interface between the A3 CPU assembly and the general purpose HP INTERFACE BUS port on the rear panel.

HP–IB transceiver U2 provides the interface between the synchronous instrument bus on the A3 CPU assembly and the asynchronous HP INTERFACE BUS port A13J2. The CPU communicates with U2 via the instrument bus. When the address decoder selects L AIB low, U2 is enabled. The A3 CPU controls the direction of data flow with the L WRITE line. Data is carried on ID0 through ID7, and is buffered by U5. Address lines IA1, IA2, and IA3 select one of sixteen registers (eight for read, eight for write) internal to U2 to send or receive data. Most of these registers control the mode or report the status of U2's internal conditions. Two registers (one for read, one for write) are the interface for data transfer between the instrument bus and the HP interface bus.

Bi–directional bus transceiver U10 buffers data lines L ADIO1 through L ADIO8 to the HP–IB bus. U10 is configured for three–state outputs with the +5VP at pin 11. The direction of data flow is determined by the L TE line, controlled by U2. When L TE is high (talk), data flows out to the HP interface bus. When L TE is low (listen), data flows into the analyzer.

Bidirectional transceiver U11 buffers the five control and three handshake lines between U2 and the HP–IB bus. The outputs are either three–state or open–collector, as defined by IEEE–488. The direction of signals through U11 is a function of L TE, L CONTROLLER, and L ATN.

When the analyzer sends information out on the HP interface bus, the A3 CPU writes a byte to U2. U2 manages the HP interface bus with the control lines, and presents the data on L DIO1 through L DIO8. U2 controls the handshake line L ADAV. The HP–IB acceptor receiving the data controls the handshake lines L ANRFD and L ANDAC. The data byte is transferred asynchronously because external acceptors control two of the handshake lines. However, the 5 MHz clock times the intervals between various states within U2.

When the analyzer receives data in from the HP interface bus, U2 recognizes its listen address (previously programmed by the A3 CPU to U2) and accepts a byte from the HP–IB port. In this mode, the external controller manages the bus. The external controller also handles the L ADAV line, while U2 controls the L ANDAC and L ANRFD lines. When the byte is accepted, U2 pulls L SRQA low to request service from the A3 CPU. The A3 CPU then reads the byte out of U2 on the instrument bus. U2 is then ready to handshake in another byte from the HP interface bus.

The latch U6 is used as a self–check for the instrument bus test which checks the ability of each data line to be set high independently of the other data lines. The A3 CPU writes a pattern to the data latch, clocks the data through, reads the data back, and then compares it with what was sent. Eighteen different patterns are tested: first all bits low, then all bits high, and finally a walking 1 is sent through all sixteen bits.

## C. 8757 SYSTEM INTERFACE

The 8757 system interface transceiver provides the interface between the A3 CPU assembly and the special purpose 8757 SYSTEM INTERFACE port on the rear panel. Only compatible microwave sources, plotters, printers, or disk drives may be connected to this port.

HP-IB transceiver U1 provides the interface between the synchronous instrument bus on the A3 CPU assembly and the asynchronous 8757 SYSTEM INTERFACE port A13J1. The CPU communicates with U1 via the instrument bus. When the address decoder selects L BIB low, U1 is enabled.

Bi-directional bus transceiver U9 buffers data lines L BDIO1 through L BDIO8 to the HP-IB bus. Bi-directional transceiver U7 buffers the five control and three handshake lines between U1 and the HP-IB bus. In all other respects, the 8757 system interface circuits are identical to the HP interface bus circuits, except that data lines ID8 through ID15 are used instead of ID0 through ID7. In firmware, the analyzer is *always* configured as the bus controller for the 8757 SYSTEM INTERFACE port. (The analyzer is never the bus controller for the HP INTERFACE BUS port.) See "B. HP Interface Bus" for circuit details.

## D. POWER SUPPLY FILTERING

The power supply filtering removes unwanted digital noise from the voltage supply lines. C1, L1, and C2 are a pi Chapter filter to remove digital noise from the +5V DIG power supply line. C3 through C12 provide additional local decoupling. R1 provides a TTL high pull-up voltage, +5VP.

## A6 Troubleshooting

This troubleshooting procedure assumes failure of at least one of the two internal diagnostic tests described in "HP-IB Diagnostic Tests". If both of these tests pass, the A6 HP-IB assembly, the HP INTERFACE BUS port, the 8757 SYSTEM INTERFACE port, and all interconnects are verified with 95% confidence. Be sure to eliminate HP-IB problems and the possibility of software bugs.

### BASIC CHECKS

Check the +5V DIG power supply to the A6 assembly. Check TP7 (5 MHZ) for a 5 MHz clock pulse. If it is missing, trace it back to the A3 CPU assembly.

### HP-IB DIAGNOSTIC TESTS

Connect an HP-IB cable between the rear panel HP INTERFACE BUS and 8757 SYSTEM INTERFACE ports. On the front panel, press **SYSTEM** **MORE** **SERVICE** **A6 HPIB INSTBUS** **HP-IB TESTS** **HP-IB LISTEN** to run the first diagnostic test. In this test, the HP INTERFACE BUS port accepts test data from the 8757 SYSTEM INTERFACE, acting as listener. If the test passes, the message HPIB TEST PASS is displayed on the CRT; other messages indicate the test failed.

Press **HP-IB TALK** to run the second diagnostic test. In this test, the HP INTERFACE BUS sends test data to the 8757 SYSTEM INTERFACE, acting as talker. If the test passes, the message HPIB TEST PASS is displayed on the CRT; other messages indicate the test failed.

If both tests pass but the analyzer in a system configuration still has HP-IB problems, suspect external cabling problems and software bugs. Be sure to eliminate these possibilities before further troubleshooting on the A6 HP-IB assembly. Refer to *Introductory Programming Guide for the HP 8757D Scalar Network Analyzer with the HP 9000 Series 200/300 Desktop Computer (BASIC)* for known good programming examples and additional HP-IB information. This introductory programming guide is in the "Remote Operation" portion of Chapter 3 of the operating manual.

If either of the diagnostic tests fails, check cable A13W1 between A11J8 on the motherboard and the A13 rear panel, near transformer T1. Try substituting another HP-IB cable.

If either diagnostic test fails, a FAIL message is displayed. This message assists in determining which line is causing the failure. As in the other tests, a displayed "1" indicates a failed line. However, due to limitations in both hardware and software, the failure message may not always be completely accurate. All control and data lines may be shown as bad when only a handshake line has failed. This test always catches a failure, but the indicated error message should only be used as a starting point for troubleshooting.

### CHECKING LINE ACTIVITY

If one diagnostic test fails while the other passes, this additional information may help with troubleshooting.

Connect an HP-IB cable between the HP INTERFACE BUS and 8757 SYSTEM INTERFACE ports and run the tests above. If only one test failed, run that test. While the test is running, check the lines with a logic probe or oscilloscope to find the defective component. Check for high or low activity as shown in Table 8-21. *Activity* means that both TTL high and low conditions occur: the logic probe blinks on and off. *High* means TTL high (+5 V): the logic probe lights brightly and does not blink. *Low* means TTL low (0 V): the logic probe goes dark and does not blink. (The third state, high impedance, may occur between pulses.)

*Table 8-21. A6 Line Activity*

Lines	Activity
Major Control Lines: L RESET 5 MHZ L WRITE L IOS	high activity activity activity
Address Lines: IA1 through IA5	activity
Address Decoder Lines: L AIB (TP5) L BIB (TP4)	activity activity
Data Lines: ID0 through ID15 L DI01 through L DI08 Interconnects between U1, U3, and U9 Interconnects between U2, U5, and U10	activity activity activity activity
Handshake Lines: L NDAC L NRFD L DAV (TP8 or TP3)	activity activity activity
HP-IB Control Lines: L ATN L SRQ L REN  L IFC L EOI	activity activity (listen) or high (talk) activity (Note that in TALK, between U1 and U7, L REN pulses are extremely narrow and infrequent. They may be missed by a logic probe.) activity activity

## INSTRUMENT BUS FAILURES

If the instrument bus test fails (error code 11), it indicates that one or more data lines cannot be toggled both high and low. This error condition will probably prevent the CRT from displaying the proper information. In addition, the error code shown on the front panel may be in error. Always check the four LEDs (labeled MSB) on the A3 CPU board for the correct error code. In the event this test fails, the CPU automatically executes the instrument bus cycle test. It will stay in this mode until the failure is fixed. This allows the operator to check the individual data and address lines.

To eliminate the possibility of shorts on other boards, first remove the display interface cable W8, the front panel interface cable W5, and the A4 ADC assembly. Run the test again. If it still fails, the problem is on either the A3 CPU assembly, the A11 motherboard, or the A6 HP-IB assembly. Using an oscilloscope, verify the correct toggling of each data line from the A3 to the A6 assembly. Typical data and address line patterns are shown in Figure 8-29. Lack of a double pulse for each of the eighteen patterns may indicate a defective latch (U6 or U8). If the instrument bus test fails at preset and the cycle is run automatically, the timing of the pulses is slightly different than if the test is performed manually or if the status switches were set to force this diagnostic test. The pattern shown in Figure 8-29 was taken when the test was performed manually (forced) which produces a cycle time of about 100 ms. It is best to set the status switches to force this diagnostic test since the resulting waveforms will more closely match those in Figure 8-29. For this and all other cycling tests, a negative-going oscilloscope trigger pulse is provided at the CONTROL 1 output connector on the rear panel.

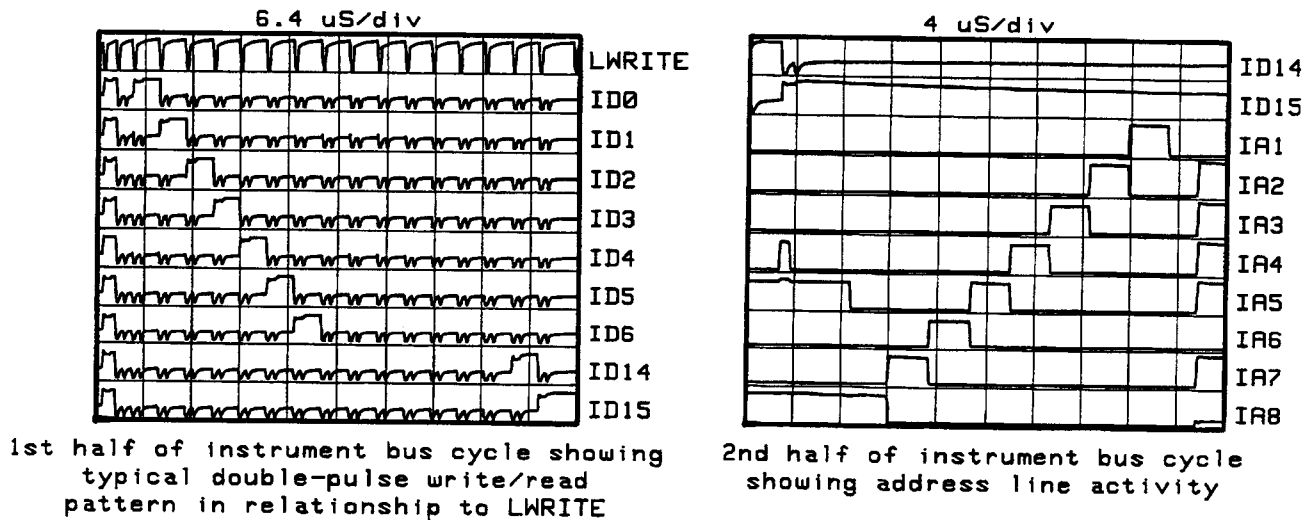


Figure 8-29. Instrument Bus Cycle

**Table 8–22. A6 Address Decoder Lines**

<b>Mnemonic</b>	<b>Address</b>	<b>Destination</b>	<b>Description</b>
L AIB	1FE10X	U2	Enables HP Interface Bus to communicate with the A3 CPU.
L BIB	1FE11X	U1	Enables 8757 System Interface to communicate with the A3 CPU.
L BLR	1FF920	U6, U8	Enables the self test latches to output their stored data onto the Instrument Data Bus.
L BLW	1FF930	U6, U8	Enables the self test latches to latch the current data into their memory.



Table 8-23. A6 Pin-Outs (1 of 2)

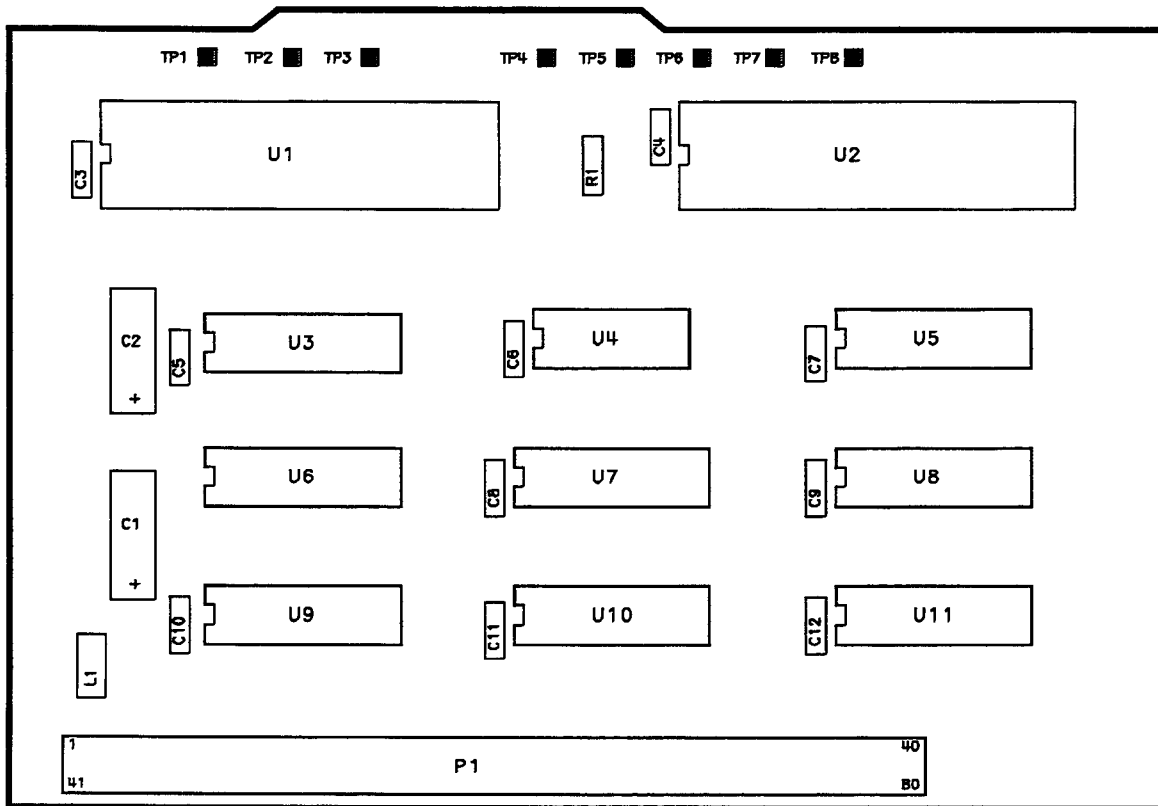
PIN	SIGNAL	I/O	SOURCE/ DESTINATION	FUNCTION BLOCK
1 41	+5V DIG +5V DIG	IN IN	A11J6-8, A6P1-1, A3P1-1, A4P2-1, A11J1-1 A11J6-9, A6P1-41, A3P1-41, A4P2-41, A11J1-2	D D
2 42	GND DIG GND DIG	IN IN	A11J6-6, A6P1-2, A3P1-2, A4P2-2, A11J1-3 A11J6-7, A6P1-42, A3P1-42, A4P2-42, A11J1-4	D D
3 43	L BDIO 1 ID15	I/O I/O	A11J8-1, A13J1-1 A6P1-43, A4P2-3, A1J7-2	C B
4 44	L BDIO 2 ID14	I/O I/O	A11J8-2, A13J1-2 A3P1-4, A4P2-4, A11J7-9	C B
5 45	L BDIO 3 ID13	I/O I/O	A11J8-3, A113J1-3 A3P1-5, A4P2-5, A11J7-12	C B
6 46	L DBIO 4 ID12	I/O I/O	A11J8-4, A13J1-4 A3P1-6, A4P2-6, A11J7-11	C B
7 47	L BDIO 5 ID11	I/O I/O	A11J8-5, A13J1-13 A3P1-7, A4P2-7, A11J7-14	C B
8 48	L BDIO 6 ID10	I/O I/O	A11J8-6, A13J1-14 A3P1-8, A4P2-8, A11J7-13	C B
9 49	L BDIO 7 ID9	I/O I/O	A11J8-7, A13J1-15 A3P1-9, A4P2-9, A11J7-16	C B
10 50	L BDIO 8 ID8	I/O I/O	A11J8-8, A13J1-6 A3P1-10, A4P2-10, A11J7-15	C B
11 51	NC ID7	I/O	A3P1-11, A4P2-11, A11J1-11, A11J7-18	B
12 52	L BREN ID6	OUT I/O	A11J8-9, A13J1-7 A3P1-12, A4P2-12, A11J1-12, A11J7-17	C B
13 53	L BIFC ID5	OUT I/O	A11J8-12, A13J1-9 A3P1-13, A4P2-13, A11J1-9, A11J7-20	C B
14 54	L BNDAC ID4	OUT I/O	A11J8-14, A13J1-8 A3P1-14, A4P2-14, A11J1-10, A11J7-19	C B
15 55	L BNRFD ID3	OUT I/O	A11J8-16, A13J1-6 A3P1-15, A4P2-15, A11J1-7, A11J7-22	C B
16 56	L BDAV ID2	OUT I/O	A11J8-18, A13J1-6 A3P1-16, A4P2-16, A11J1-8, A11J7-21	C B
17 57	L DEOI ID1	OUT I/O	A11J8-10, A13J1-5 A3P1-17, A4P2-17, A11J1-5, A11J7-24	C B
18 58	L BATN ID0	OUT I/O	A11J8-20, A13J1-11 A3P1-18, A4P2-18, A11J1-6, A11J7-23	C B
19 59	L BSQR IA7	OUT IN	A11J8-22, A13J1-10 A3P1-60, A4P2-19, A4P2-59, A11J1-13	C A
20 60	IA8 IA6	IN IN	A3P1-61, A4P2-61, A11J1-14 A3P1-20, A4P2-60, A11J1-16	B A
21 61	NC IA5	IN	A3P1-21, A4P2-21, A11J1-15	A
22 62	NC IA4	IN	A3P1-22, A4P2-22, A11J1-18	A
23 63	NC IA3	IN	A3P1-23, A4P2-23, A11J1-17	B,C
24 64	L ADIO 1 IA2	I/O IN	A11J8-24, A13J2-1 A3P1-24, A4P2-24, A11J1-20	B B,C

Table 8-23. A6 Pin-Outs (2 of 2)

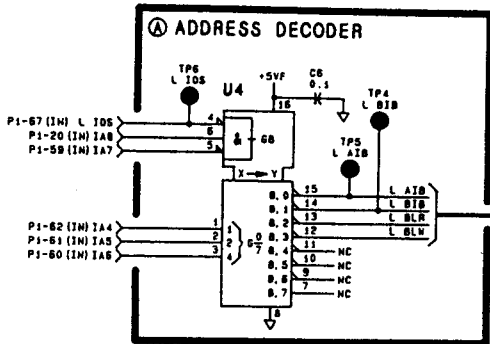
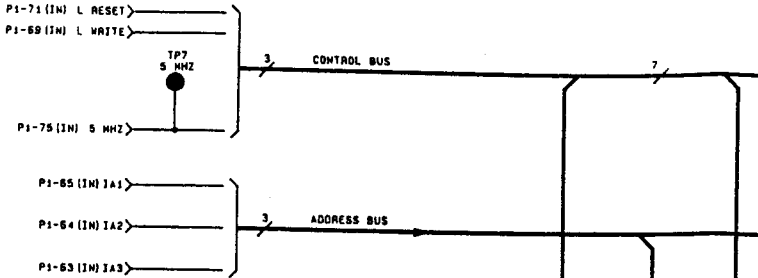
PIN	SIGNAL	I/O	SOURCE/ DESTINATION	FUNCTION BLOCK
25 65	L ADIO 2 IA1	I/O IN	A11J8-25, A13J2-2B A3P1-25, A4P2-25, A11J1-19	B B,C
26 66	L ADIO 3 GND DIG SH	I/O	A11J8-26, A13J2-3 Refer to A11 Wiring Schematic	B D
27 67	L ADIO 4 L IOS	I/O IN	A11J8-27, A13J2-4 A3P1-27, A4P2-27, A11J1-21	B A
28 68	L ADIO 5 GND DIG SH	I/O	A11J8-28, A13J2-13 Refer to A11 Wiring Schematic	B D
29 69	L ADIO 6 L WRITE	I/O IN	A11J8-29, A13J2-14 A3P1-29, A4P2-29	B B,C
30 70	L ADIO 7 GND DIG SH	I/O	A11J8-30, A13J2-15 Refer to A11 Wiring Schematic	B D
31 71	L ADIO 8 L RESET	I/O IN	A11J8-31, A13J2-16 A3P1-31, A4P2-31, A11J1-23	B B
32 72	NC L SRQA	OUT	A13P1-70	B
33 73	L AREN L SRQB	OUT OUT	A11J8-32, A13J2-13 A3P1-33	B C
34 74	L AIFC NC	OUT	A11J8-35, A13J2-9	B
35 75	L ANDAC 5MHZ	OUT IN	A11J8-37, A13J2-8 A3P1-35	B B,C
36 76	L ANRFD NC	OUT	A11J8-39, A13J2-7	B
37 77	L ADAV NC	OUT	A11J8-41, A13J2-6	B
38 78	L AEOI NC	OUT	A11J8-33, A13J2-5	B
39 79	L AATN SPARE	OUT	A11J8-43, A13J2-11 Not currently used.	B
40 80	L ASRQ SPARE GND	OUT	A11J8-45, A13J2-10 Not currently used	B

*Replaceable Parts List for A6 Assembly (1 of 1)*

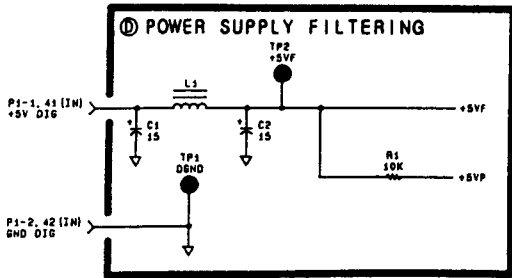
Reference Designation	HP Part Number	Qty	Description	Mfr Code	Mfr Part Number
A6	08757-60006	1	BOARD ASSY-HPIB	28480	08757-60006
A6C1-C2	0180-3888	1	CAP-FXD 15uF ±10% 25 V TA	04200	173D156X9025X
A6C3 - C12	0160-4835	7	CAP-FXD 0.1uF ±10% 50 V CER X7R	02010	SA105C104KAAH
A6L1	08503-80001	1	COIL TOROID		
A6MP2	4040-0754	2	EXTR-PC BD BLU POLYC .062-IN-BD-THKNS	10456	
A6MP3	1480-0073	2	PIN-ROLL .062-IN-DIA .25-IN-LG BE-CU	04559	99-012-062-0250
A6P1	1251-7907	1	CONN-POST TYPE .100-PIN-SPCG 80-CONT	01380	534204-8
A6R1	0757-0442	1	RESISTOR 10K ±1% .125W TF TC=0±100	05524	CMF-55-1
A6TP1 - TP8	0360-0535	7	CONNECTOR-SGL CONT TML-TS-PT	13296	
A6U1-U2	1820-2548	1	IC-GENERAL PURPOSE INTERFACE BUS ADAPTER	01698	
A6U3	1820-2075	1	IC TRANSCEIVER TTL/LS BUS OCTL	01698	SN74LS245N
A6U4	1820-1216	1	IC DCDR TTL/LS BIN 3-TO-8-LINE 3-INP	01698	SN74LS138N
A6U5	1820-2075	1	IC TRANSCEIVER TTL/LS BUS OCTL	01698	SN74LS245N
A6U6	1820-1997	1	IC FF TTL/LS D-TYPE POS-EDGE-TRIG PRL-IN	03406	DM74LS374N
A6U7	1820-3513	1	IC-INTERFACE XCVR	03406	DS75161AN
A6U8	1820-1997	1	IC FF TTL/LS D-TYPE POS-EDGE-TRIG PRL-IN	03406	DM74LS374N
A6U9-U10	1820-3431	1	IC-INTERFACE XCVR	03406	DS75160AN
A6U11	1820-3513	1	IC-INTERFACE XCVR	03406	DS75161AN

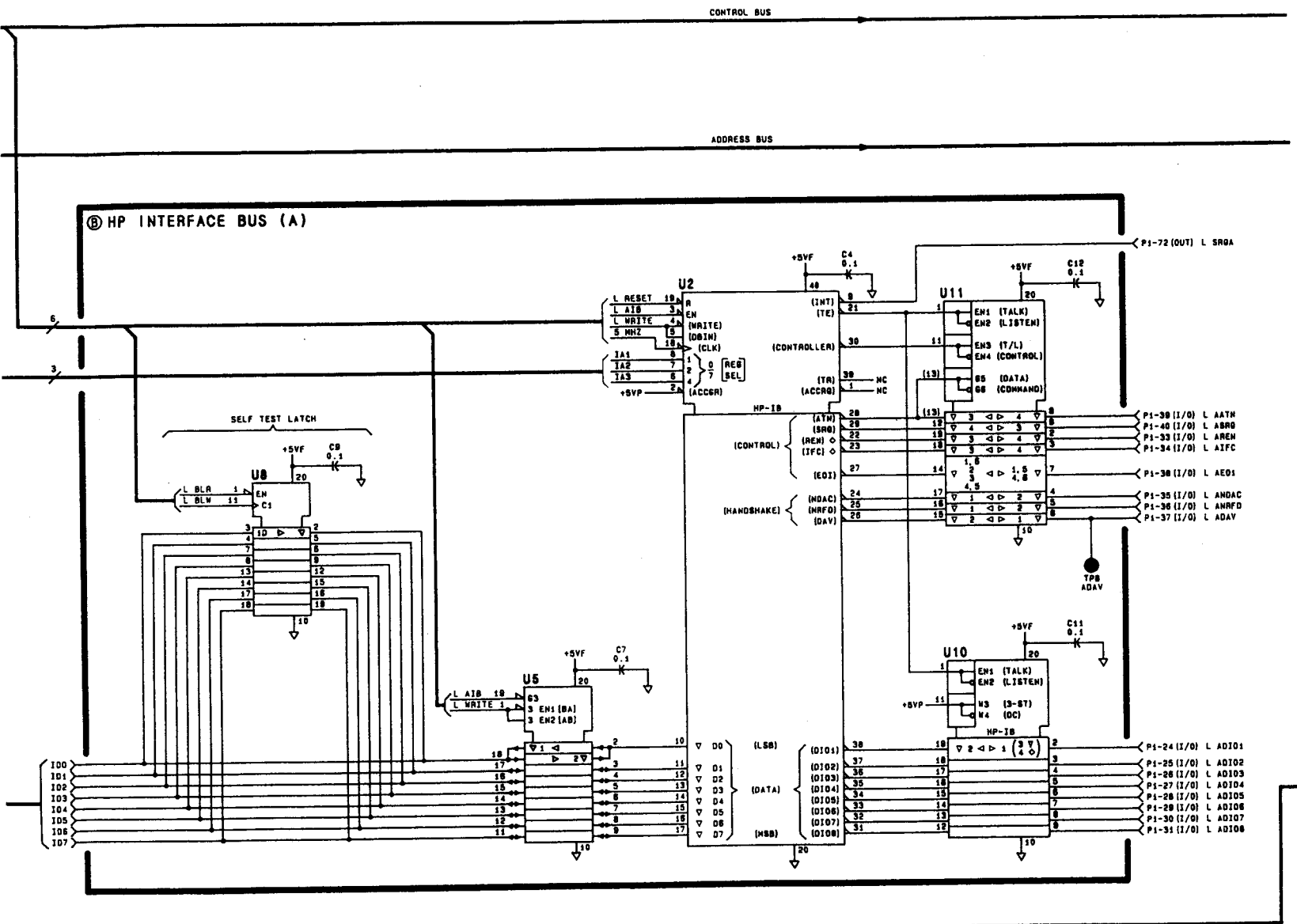


*Figure 8-30. A6 Component Locations Diagram*

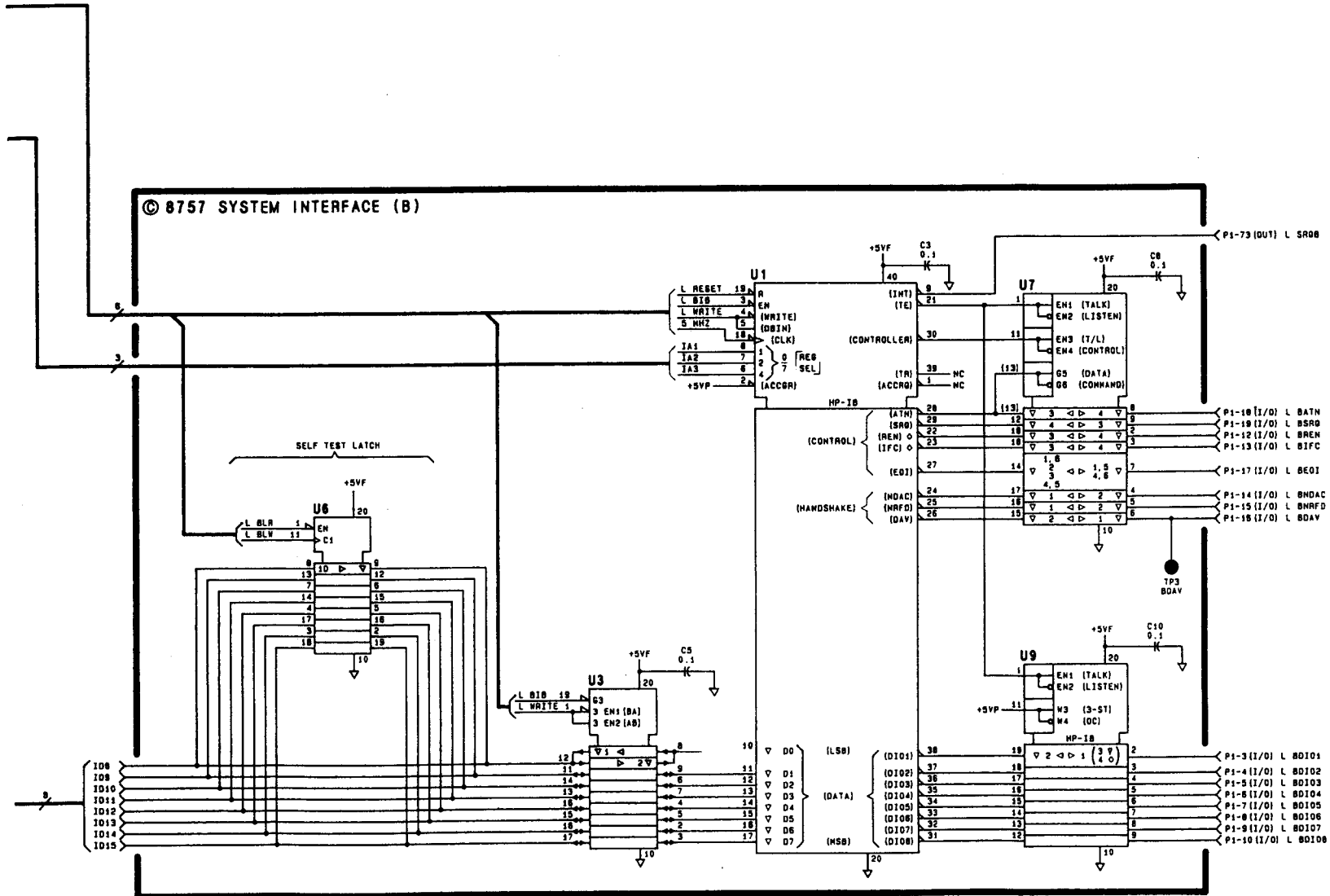


- P1-58 (I/O) ID0
- P1-57 (I/O) ID1
- P1-56 (I/O) ID2
- P1-55 (I/O) ID3
- P1-54 (I/O) ID4
- P1-53 (I/O) ID5
- P1-52 (I/O) ID6
- P1-51 (I/O) ID7
- P1-50 (I/O) ID8
- P1-49 (I/O) ID9
- P1-48 (I/O) ID10
- P1-47 (I/O) ID11
- P1-46 (I/O) ID12
- P1-45 (I/O) ID13
- P1-44 (I/O) ID14
- P1-43 (I/O) ID15





© 8757 SYSTEM INTERFACE (B)



## A7/A8/A9/A10 Log Amplifiers

### CIRCUIT DESCRIPTION

The A7/A8/A9/A10 log amplifiers are identical assemblies. The circuit description, troubleshooting information, component locations diagram and schematic diagram apply to all these assemblies.

The A7, A8, A9, and A10 log amplifier assemblies perform the logarithmic shaping and DC rectification of the 27.778 kHz A, B, C, and R inputs respectively.

The external detectors (or directional bridges) peak detect the 27.778 kHz modulated microwave signal. Thus, the signal at the A, B, C, or R input of the analyzer is a 27.778 kHz square wave with amplitude proportional to the detected power level. The A, B, C, and R inputs are routed to the A7, A8, A9, and A10 log amplifiers respectively. Here each signal is buffered, logged, rectified, and filtered. The resulting signal, which is proportional to the input power level, is then sent to the A4 ADC board for processing.

In addition to performing as a log amplifier, the A7–A10 assembly has the capability to monitor its own temperature and ground reference level. Any of these three signals can be output to the A4 ADC assembly.

Because the log amplifiers do not compensate for the square–law to linear effects of diode detection, the output voltage does not have a 1:1 relationship to power level in dBm. For example, a 1 dB change in power at the detector at +10 dBm produces an output voltage change of about 100 mV. At –10 dBm the change is about 150 mV/dB, and at –20 dBm and below the change is about 200 mV/dB.

### A. INPUT AMPLIFIER

Q11 and Q12 form an AC–coupled, low noise, differential–input amplifier biased by constant current source Q13. The differential current then drives FLT1 which provides bandpass filtering, level shifting, and conversion from a double–ended to a single–ended signal. Overvoltage and static protection is provided by CR1, CR2, VR3, VR4, C1, and C3. The overall gain from TP1 to TP2 is about –1 at 27.778 kHz with a bandwidth of 1.9 kHz.

### B. 13/26 DB AMPLIFIER

The output of the input amplifier drives Q8, the first stage of a feedback amplifier, which in turn differentially drives Q1 and Q3. The current mirror of Q5 and Q4 then provides the double–ended to single–ended conversion. The resulting single–ended current is driven into R27, R28, and R29, providing feedback to Q8. Q9 and Q2 are 2 mA current sources. The voltage produced at the collector of Q3 is buffered by U1A. R27, R28, and R29 also provide a 13 dB gain tap off. This is buffered by U1B to provide the +13 dB input to the logger.

### C. 13 DB GAIN STAGES

The 13 dB amplifiers provide inputs to the logger IC in 13 dB increments starting with the signal at TP3. All stages (except U3A) have input and feedback diodes to limit the output voltages to  $\pm 2$  diode drops. These, together with the 1K coupling resistors, prevent saturation of the amplifiers. All the stages are AC coupled. FLT2 is a bandpass filter which limits the noise reaching the highest gain stages.

### D. 13 DB ATTENUATION STAGES

The resistor divider made up of R69, R71, R76, and R78 provides three more taps at 13 dB attenuation increments. These taps are buffered by non-inverting amplifiers U8A, U9A, and U9B and then fed to the logger IC. These stages are attenuated enough that they need no diode limiting. The 0 dB reference stage (the same amplitude as TP3) is reconstructed in U8B by amplifying the 13 dB attenuation stage by 13 dB. This is done to allow clamping of this stage with feedback diodes.

### E. 6.3V REFERENCE/BIAS

This circuit keeps the logger bias current at a constant level (approximately 6 mA) over time and temperature. U6B generates the positive supply (from VR2), and U6A generates the negative supply ( $-8.4$  V) to ensure quiet reference levels. R94, R95, and CR10 ensure the start-up of VR2, however, CR10 is reverse biased in normal operation. U12 controls the logger bias current at U10 pins 1 and 2 by comparing a reference level of  $\approx 9.45$  V at U12 pin 2 to the voltage across R93. R93 senses the total logger bias current. A feedback loop is formed from the output of U12, through R97 and R98, controlling U10 pins 1 and 2. This, in turn, creates a current of opposite phase at TP7. This current flows through R93 to produce the voltage at U12 pin 3, thereby completing the loop.

### F. LOGGER

The twelve gain and attenuation stages are all fed to the logger IC U10, where they drive internal differential transistor pairs. The collector currents are summed, and leave U10 at pins 12 and 13. This produces a log relationship between voltage in and current out. Q6 and Q7 provide low impedance loading of the logger IC U10. FLT3 acts as a bandpass filter and provides a current sensing center tap for the bias circuitry. It also converts the output to a single-ended signal and provides a voltage gain of 2.

### G. MULTIPLEXER/RECTIFIER

U4 selects one of three signals to output. The first is the logged signal from U10. The second is a temperature signal, also from U10. This provides a  $21$  mV/ $^{\circ}$ C output at TP10. The third disconnects the log signal and grounds the input to the rectifier to establish a zero reference point.



The rectifier circuit converts the 27.778 kHz signal to a full-wave rectified dc signal. U5 and its associated feedback components form a half-wave rectifier. The half-wave rectified signal is doubled, inverted, and summed in U7 with the original signal from R103 and R104, resulting in a full-wave rectified signal. U7 also provides some low-pass filtering through C69, as well as a dc offset and a gain of 5. The overall circuit sensitivity is set by R112 to be about 100 mV/dB with a +10 dBm input level to the detector.

## **H. 5 KHZ LOWPASS FILTER**

This circuit contains four poles of a five-pole, lowpass, Butterworth filter with a 5 kHz cutoff and a gain of 1. The fifth pole is in the rectifier stage. U13 controls both stages of the two-pole multiloop lowpass filter.

## **I. POWER SUPPLY FILTERING**

LC filtering is used on the 15 volt supplies to keep the 27.778 kHz signals from propagating to the rest of the instrument. Each op amp has its own local RC filtering circuit on the  $\pm 15$  volt supply. Because of the small current drain, an RC filter is used on the +5 volt supply.

## A7/A8/A9/A10 Troubleshooting

The A7, A8, A9, and A10 log amplifiers are four identical assemblies corresponding to the four front panel input. The A7, A8, A9, and A10 assemblies perform the logarithmic shaping and DC rectification of the 27.778 kHz A, B, C, and R inputs respectively. The troubleshooting information in this Chapter applies to all four assemblies.



**Do NOT adjust or interchange any of the log amplifiers.**

Calibration data is stored in EEPROM on the A3 CPU assembly to correct variations in the response of each log amplifier. Therefore, adjusting or interchanging log amplifiers, or replacing any component on a log amplifier requires recalibration of the analyzer with the HP 11613A/B. Log amplifier assemblies may be interchanged for troubleshooting purposes, but they must be returned to their original positions.

**NOTE:** If a problem is seen at only one input (A, B, C, or R), troubleshoot the corresponding log amplifier assembly. If the same problem is seen at all the inputs, suspect problems in the test setup, the detector bias, or the A4 ADC assembly.

Test conditions for the A7, A8, A9, and A10 log amplifiers and all waveforms are as follows:

Power level: +10.0 dBm at an external detector connected to the appropriate input.

Modulation: 27.778 kHz square wave modulation, 50–50 duty cycle, with at least 30 dB on/off ratio. If a source with internal modulation is used, check the modulation frequency with a frequency counter. Note that some overshoot or ringing may be visible at the detector output when internal modulation is used. If an external modulator is used, adjust the power level at the source to compensate for power losses through it. (The waveforms in Figure 8–32 were taken using an external modulator.)

Frequency: Any CW frequency within the range of the detector.

**NOTE:** The LC filter assemblies FLT1, FLT2, and FLT3 are preset and sealed at the factory. If any portion of one of these filters requires repair, replace the entire filter assembly. The capacitor is not separately replaceable. Each filter is tuned to a slightly different frequency. Do not attempt to adjust any of these assemblies.

### GENERAL TROUBLESHOOTING

This troubleshooting Chapter is divided into two parts. The first part covers general troubleshooting for instrument problems and defective components. The second part covers the troubleshooting of noisy, unstable, but otherwise functioning and reasonably accurate log amplifiers.

## Basic Checks

Set up the equipment as shown in Figure 8–5, “Overall Troubleshooting Block Diagram”, with the detector connected to the appropriate input. With a +10.0 dBm square wave modulated input to the detector, check for a square wave of approximately 3 V peak–to–peak at the A7/A8/A9/A10 log amplifier input TP1 (block A). If this signal is absent, check the cables W1, W2, W3, and W4 between the A, B, C, and R inputs and the A11 motherboard. Check the bias cables from the A2 front panel interface to the A, B, C, and R inputs. There should be +15 V and –12.6 V bias signals present at each of the input connectors. If no problem is found here, suspect the detector or source. Check the source output power level with modulation off (modulation on causes a drop in measured power level of approximately 3 dB). Check the square wave modulation frequency with a crystal detector and frequency counter. Substitute an external modulator if necessary.

If a 3 V p–p square wave input signal is found at TP1, check the output voltages from the A7/A8/A9/A10 log amplifiers to the A4 ADC assembly, at TP9 (block H). Be certain the detector is connected to the input being measured. The typical log amplifier output voltage, with +10 dBm applied to the detector, is +6.5 V. The typical log amplifier output voltage with –30 dBm applied to the detector is +0.2 V.

If the correct voltages are present, trace the signals to the A4 ADC assembly. See “A4 ADC Troubleshooting” if necessary.

## Assembly Troubleshooting

Check the power supply inputs to the board. Check the voltage at VR2 (block E): it should be within 1% of 6.3 V. Verify the reference supplies generated from VR2: the output of Q10 should be +12.6 V; U6 pin 1 should be –8.6 V; and TP7 should be +9.45 V. If these voltages are correct within 3%, but the BIAS 1 and BIAS 2 inputs to the logger IC U10 are not approximately –4 V and –7 V respectively, then U10 is probably defective.

A failure in any of the +13 dB gain stages (block C) will affect succeeding stages. Depending upon its location, any failure in this block will usually produce only a slight error in higher level signals. Low level signals will make any failures in these stages more apparent.

A failure in the 13 dB attenuation stages (block D) will produce large offsets at higher power levels that are usually easy to find.

With +10 dBm applied to the detector, compare the waveforms with Figure 8–32. The voltage levels and wave shapes should be nearly identical with the illustration. All inputs to logger U10 (block F) must be centered about 0.0 V. This verifies that the circuits in blocks A, B, C, and D are functional, but does not verify that their gain is correct. The next step is to verify the correct gain of each stage.

The gain of any stage in block B or C is 4.6, or about 13 dB. This, however, is not readily apparent, since most of the stages are clipped. If the gain of any stage is in question, adjust the power level to the detector so that the input to the stage is a 130 mV p–p sine wave. The output should then be a 600 mVp–p sine wave (just below the clipping level).

An alternative method to check the gain is to vary the input power level and observe when the inputs to U10 reach a certain voltage. Table 8–24 gives the approximate detector input power level required to obtain a 600 mV p–p signal at the indicated pin of U10. These power levels are only approximate.

**Table 8–24. Pin U10 Versus Power Level**

U10 Pin Number	Power Level (dBm) to Obtain 600 mV p–p
19	> +20
18	+17
17	+6
16	–5
15	–14
14	–21
8	–28
7	–34
6	–41
5	–47
4*	–53
3*	–59

\*These input pins will be noisy.

If the proper inputs are present at logger U10 and the bias voltages are normal, the output should be similar to the waveform shown for TP8 in Figure 8–32. If the waveform is substantially different, suspect U10, FLT3, or U4. The voltage at U10 pins 9 and 11 should be about 0.6 V. This voltage is used as the temperature indicator and will vary about 2.2 mV/°C.

The multiplexer (block G) is most easily checked by performing the channel volts logger cycle. Press **SYSTEM MORE SERVICE A4 ADC MORE CHANNEL VOLTS CHANY LOGGER**. The multiplexer is cycled through its three possible states and the A4 ADC reads the resulting voltages and displays them on the CRT. (The L LOG ZERO and L LOG TEMP lines can be checked with an oscilloscope. Both should have groups of four digital pulses, one for each possible input.) The display on the CRT will show the readings for the four logger boards. The DATA reading corresponds to the logged signal output ( $\cong +6.5$  V for the +10 dBm input,  $\cong -6.5$  V at the noise floor). The DC OFFSET reading is output when the multiplexer input is grounded. This voltage (because it is offset) should be close to –7.8 V. The TEMP reading is related to the ambient temperature. This reading will vary from unit to unit but is typically around 1 to 3 V and will vary 21 mV/°C.

The rectifier consists of U5 and U7. The output of U5 should be a half–wave rectified signal (the positive portion is clipped in the normal measurement mode). This is summed with the original signal in U7 to produce a full–wave rectified signal as shown in Figure 8–32 with a +10 dBm input. The overall gain of this circuit with a DC signal (TEMP or ZERO mode) is 10. Voltages can most easily be traced by grounding U4 pins 10 and 15. This sets the multiplexer to select the input from U10 pin 9. TP9 and TP10 should then be about 10 times this voltage.

Block H is a 5 kHz lowpass filter consisting of U13 and associated circuitry. This stage has a gain of about 1.

## Noise Problems

Tracking down noise problems in this circuit may be difficult since the noise may be riding on a 27.778 kHz signal. A differential input oscilloscope is recommended for troubleshooting noise in the reference/bias supplies. If this is not available, use a 1:1 probe for the following checks.

**NOTE:** Ensure that the capacitor leads on FLT1, 2, and 3 do NOT touch the core of the inductors. This will degrade the noise performance of the log amplifier. Tapping on the cores (or the can of FLT1) should produce noise spikes of less than 0.1 dB. Larger spikes or drift may indicate unwanted contact with the inductor core.

1. With no input applied, check for noise in the reference/bias supply using a differential amplifier, if possible (or a 1:1 probe). Check VR2 and the outputs of Q10, U6A, and U12. Compare the results with a known good board.
2. Ground U4 pin 15 and pin 10. Set the analyzer to read the appropriate input (A, B, C, or R), and observe the resulting trace on the CRT using a scale of 0.1 dB/div to see if the noise is still present. The trace will be around  $-40$  dBm. If the noise is still present, the source is in blocks G or H.
3. Short U1 pins 1 and/or 7 to ground. If the noise is eliminated, the source is probably in blocks A or B.
4. Short TP2 to ground. If the noise is eliminated, the source is probably in block A.
5. Temporarily ground U10 pins 19, 18, 17, and 16 one at a time. Then view the resulting trace on the CRT. If the noise is eliminated, the source is probably in block D.
6. With no input applied, view the outputs of U1, U2, U3, and U11 using a 1:1 probe. Compare these results with a known good board.
7. If tests 2, 5, and 6 do not pinpoint the problem, the fault is either in U10 or in block E.

Table 8-25. A7/A8/A9/A10 Pin Outs (1 of 4)

A7

PIN	SIGNAL	I/O	SOURCE/ DESTINATION	FUNCTION BLOCK
1 19	GND PLANE GND PLANE	IN IN	A11J6-4 A11J6-4	G G
2 20	A IN SHLD A IN SHLD	IN IN	A11J2-1 A11J2-1	A A
3 21	INA INA	IN IN	A11J2-2 A11J2-2	A A
4 22	INARTN INARTN	IN IN	A11J2-3 A11J2-3	A A
5 23	A IN SHLD A IN SHLD	IN IN	A11J2-1 A11J2-1	A A
6 24	GND PLANE GND PLANE	IN IN	A11J6-4 A11J6-4	G G
7 25	-15V -15V	IN IN	A11J6-13 A11J6-13	G G
8 26	NC NC			
9 27	GND PLANE GND PLANE	IN IN	A11J6-4 A11J6-4	G G
10 28	+5V +5V	IN IN	A11J6-11 A11J6-11	G G
11 29	NC NC			
12 30	+15V +15V	IN IN	A11J6-14 A11J6-14	G G
13 31	GND PLANE GND PLANE	IN IN	A11J6-4 A11J6-4	G G
14 32	L LOG TEMP NC	IN	A4P2-34	G G
15 33	L LOG ZERO NC	IN	A4P2-35	G
16 34	NC LOG A COM	OUT	A4P1-27	F
17 35	NC LOG A	OUT	A4P1-9	F
18 36	GND PLANE GND PLANE	IN IN	A11J6-4 A11J6-4	G G

Table 8–25. A7/A8/A9/A10 Pin Outs (2 of 4)

A8

PIN	SIGNAL	I/O	SOURCE/ DESTINATION	FUNCTION BLOCK
1 29	GND PLANE GND PLANE	IN IN	A11J6–4 A11J6–4	G G
2 20	B IN SHLD B IN SHLD	IN IN	A11J3–1 A11J3–1	A A
3 21	INB INB	IN IN	A11J3–2 A11J3–2	A A
4 22	INBRTN INBRTN	IN IN	A11J3–3 A11J3–3	A A
5 23	B IN SHLD B IN SHLD	IN IN	A11J3–1 A11J3–1	A A
6 24	GND PLANE GND PLANE	IN IN	A11J6–4 A11J6–4	G G
7 25	–15V –15V	IN IN	A11J6–13 A11J6–13	G G
8 26	NC NC			
9 27	GND PLANE GND PLANE	IN IN	A11J6–4 A11J6–4	G G
10 28	+5V +5V	IN IN	A11J6–11 A11J6–11	G G
11 29	NC NC			
12 30	+15V +15V	IN IN	A11J6–14 A11J6–14	G G
13 31	GND PLANE GND PLANE	IN IN	A11J6–4 A11J6–4	G G
14 32	L LOG TEMP NC	IN	A4P2–34	G
15 33	L LOG ZERO NC	IN	A4P2–35	G
16 34	NC LOG B COM	OUT	A4P1–28	F
17 35	NC LOG B	OUT	A4P1–10	G
18 36	GND PLANE GND PLANE	IN ON	A11J6–4 A11J6–4	G G

Table 8–25. A7/A8/A9/A10 Pin Outs (3 of 4)

A9

PIN	SIGNAL	I/O	SOURCE/ DESTINATION	FUNCTION BLOCK
1 19	GND PLANE GND PLANE	IN IN	A11J6–4 A11J6–5	G G
2 20	C IN SHLD C IN SHLD	IN IN	A11J4–1 A11J4–1	A A
3 21	INC INC	IN IN	A11J4–2 A11J4–2	A A
4 22	INCRTN INCRTN	IN IN	A11J4–3 A11J4–3	A A
5 23	C IN SHLD C IN SHLD	IN IN	A11J4–1 A11J4–1	A A
6 24	GND PLANE GND PLANE	IN IN	A11J6–4 A11J6–4	G G
7 25	–15V –15V	IN IN	A11J6–13 A11J6–13	G G
8 26	NC NC			
9 27	GND PLANE GND PLANE	IN IN	A11J6–4 A11J6–4	G G
10 28	+5V +5V	IN IN	A11J6–11 A11J6–11	G G
11 29				
12 30	+15V +15V	IN IN	A11J6–14 A11J6–14	G G
13 31	GND PLANE GND PLANE	IN IN	A11J6–4 ALLJ6–4	G G
14 32	L LOG TEMP NC	IN	A4P2–34	G
15 33	L LOG ZERO	IN	A4P2–35	G
16 34	NC LOG C COM	OUT	A4P1–29	F
17 35	NC LOG C	OUT	A4P1–11	F
18 36	GND PLANE GND PLANE	IN IN	A11J6–4 ALLJ6–4	G G



Table 8-25. A7/A8/A9/A10 Pin Outs (4 of 4)

A10

PIN	SIGNAL	I/O	SOURCE/ DESTINATION	FUNCTION BLOCK
1 19	GND PLANE GND PLANE	IN IN	A11J6-4 A11J6-4	G G
2 20	R IN SHLD R IN SHLD	IN IN	A11J5-1 A11J5-1	A A
3 21	INR INR	IN IN	A11J5-2 A11J5-2	A A
4 22	INRRTN INRRTN	IN IN	A11J5-3 A115-3	A A
5 23	R IN SHLD R IN SHLD	IN IN	A11J5-1 A11J5-1	A A
6 24	GND PLANE GND PLANE	IN IN	A11J6-4 A11J6-4	G G
7 25	-15V -15V	IN IN	A11J6-13 A11J6-13	G G
8 26	NC NC			
9 27	GND PLANE GND PLANE	IN IN	A11J6-4 A11J6-4	G G
10 28	+5V +5V	IN IN	A11J6-11 A11J6-11	G G
11 29	NC NC			
12 30	+15V +15V	IN IN	A11J6-14 A11J6-14	G G
13 31	GND PLANE GND PLANE	IN IN	ALLJ6-4 A11J6-4	G G
14 32	L LOG TEMP NC	IN	A4P2-34	G
15 33	L LOG ZERO NC	IN	A4P2-35	G
1 34	NC LOG R COM	OUT	A4P1-30	F
17 35	NC LOG R	OUT	A4P1-12	F
18 36	GND PLANE GND PLANE	IN IN	A11J6-4 A11J6-4	G G

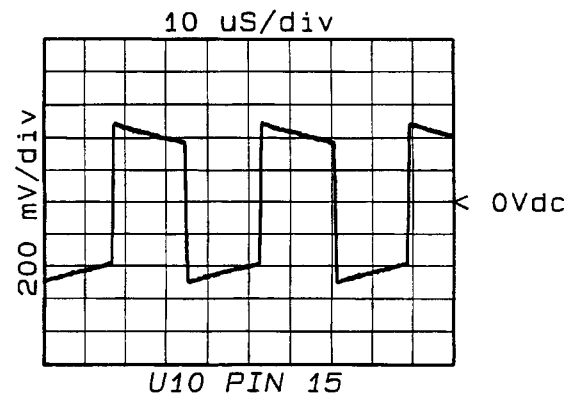
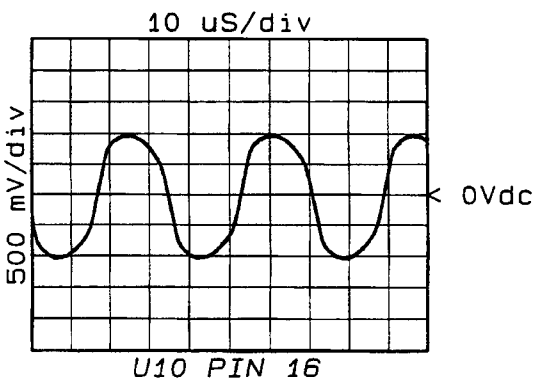
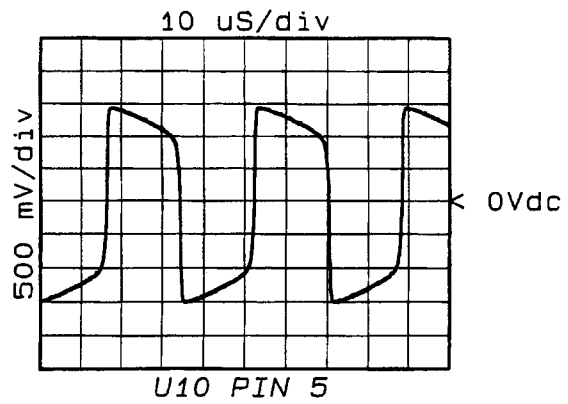
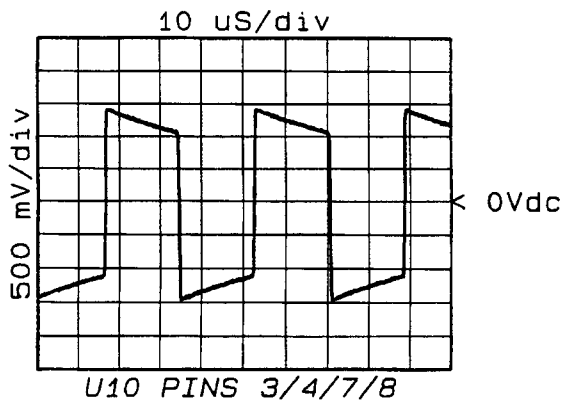
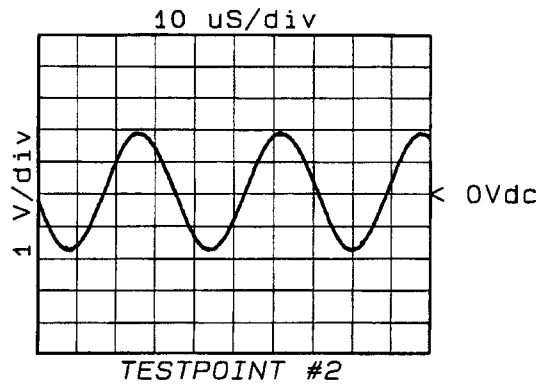
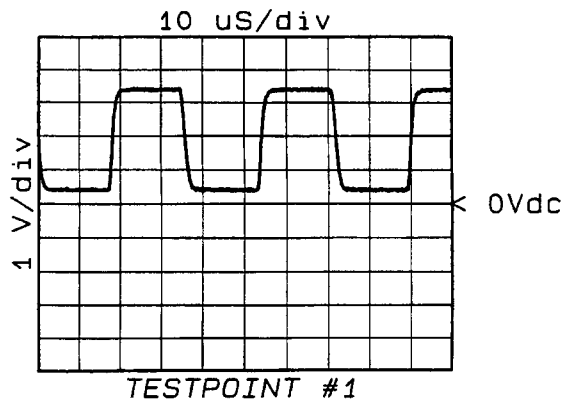


Figure 8-32. Typical Waveforms at Selected Points with +10 dBm Applied to Detector (1 of 2)

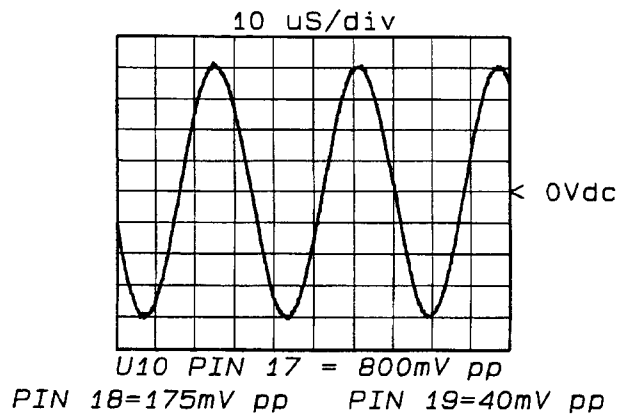
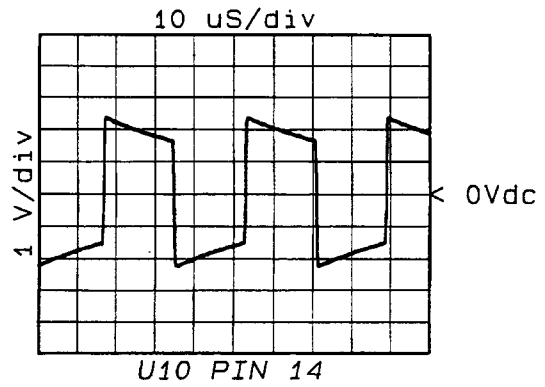
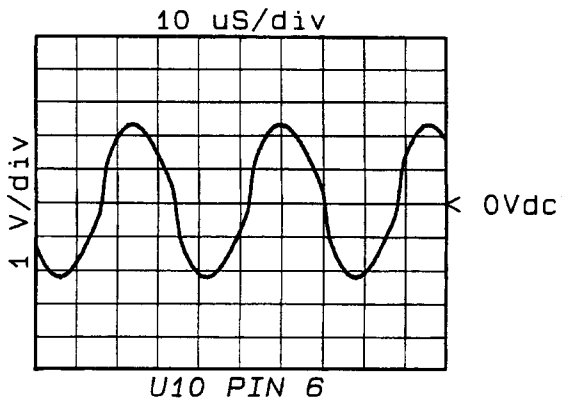
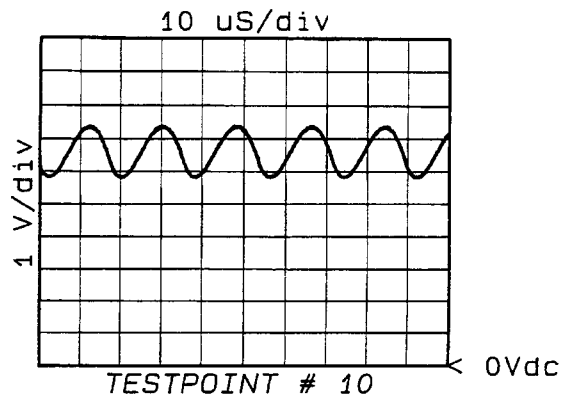
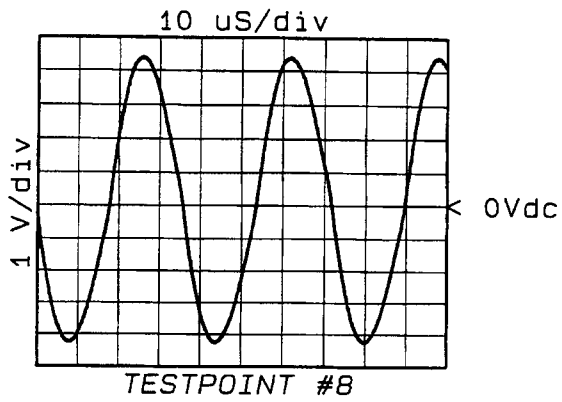


Figure 8-32. Typical Waveforms at Selected Points with +10 dBm Applied to Detector (2 of 2)

*Replaceable Parts List for A7, A8, A9, and A10 Assemblies (1 of 4)*

Reference Designation	HP Part Number	Qty	Description	Mfr Code	Mfr Part Number
A7, A8, A9, A10	08757-60087	1	BD ASSY-LOG AMP	28480	08757-60058
A7C1-C3	0180-4129	1	CAP-FXD 1uF ±10% 35 V TA	04200	173D105X9035V
A7C5	0160-4801	1	CAP-FXD 100pF ±5% 100 V CER C0G	02010	SA102A101JAAH
A7C6-C7	0160-4918	1	CAP-FXD 0.022uF ±10% 50 V CER X7R	02010	SA105C223KAAH
A7C8-C9	0180-4129	1	CAP-FXD 1uF ±10% 35 V TA	04200	173D105X9035V
A7C10	0160-4835	1	CAP-FXD 0.1uF ±10% 50 V CER X7R	02010	SA105C104KAAH
A7C11	0180-4129	1	CAP-FXD 1uF ±10% 35 V TA	04200	173D105X9035V
A7C12	0160-4824	1	CAP-FXD 680pF ±5% 100 V CER C0G	02010	SA101A681JAAH
A7C13	0160-4835	1	CAP-FXD 0.1uF ±10% 50 V CER X7R	02010	SA105C104KAAH
A7C14-C16	0180-4129	1	CAP-FXD 1uF ±10% 35 V TA	04200	173D105X9035V
A7C17	0160-4835	1	CAP-FXD 0.1uF ±10% 50 V CER X7R	02010	SA105C104KAAH
A7C18-C19	0180-4129	1	CAP-FXD 1uF ±10% 35 V TA	04200	173D105X9035V
A7C20-C21	0160-4835	1	CAP-FXD 0.1uF ±10% 50 V CER X7R	02010	SA105C104KAAH
A7C23-C24	0180-4129	1	CAP-FXD 1uF ±10% 35 V TA	04200	173D105X9035V
A7C25-C26	0160-4835	1	CAP-FXD 0.1uF ±10% 50 V CER X7R	02010	SA105C104KAAH
A7C27-C28	0180-4129	1	CAP-FXD 1uF ±10% 35 V TA	04200	173D105X9035V
A7C29	0160-4835	1	CAP-FXD 0.1uF ±10% 50 V CER X7R	02010	SA105C104KAAH
A7C30-C31	0180-4132	1	CAP-FXD 6.8uF ±10% 35 V TA	04200	173D685X9035X
A7C32-C35	0180-4129	1	CAP-FXD 1uF ±10% 35 V TA	04200	173D105X9035V
A7C36-C48	0160-4835	9	CAP-FXD 0.1uF ±10% 50 V CER X7R	02010	SA105C104KAAH
A7C49-C51	0180-4129	1	CAP-FXD 1uF ±10% 35 V TA	04200	173D105X9035V
A7C52	0160-4835	1	CAP-FXD 0.1uF ±10% 50 V CER X7R	02010	SA105C104KAAH
A7C53-C54	0180-4129	1	CAP-FXD 1uF ±10% 35 V TA	04200	173D105X9035V
A7C55	0160-4835	1	CAP-FXD 0.1uF ±10% 50 V CER X7R	02010	SA105C104KAAH
A7C56	0180-4129	1	CAP-FXD 1uF ±10% 35 V TA	04200	173D105X9035V
A7C57	0160-4835	1	CAP-FXD 0.1uF ±10% 50 V CER X7R	02010	SA105C104KAAH
A7C58-C60	0180-4129	1	CAP-FXD 1uF ±10% 35 V TA	04200	173D105X9035V
A7C62	0160-4834	1	CAP-FXD 0.047uF ±10% 100 V CER X7R	02010	SA301C473KAAH
A7C63	0160-4814	1	CAP-FXD 150pF ±5% 100 V CER C0G	02010	SA101A151JAAH
A7C65	0160-4834	1	CAP-FXD 0.047uF ±10% 100 V CER X7R	02010	SA301C473KAAH
A7C67	0180-4129	1	CAP-FXD 1uF ±10% 35 V TA	04200	173D105X9035V
A7C68	0180-4129	1	CAP-FXD 1uF ±10% 35 V TA	04200	173D105X9035V
A7C69-C70	0160-4824	1	CAP-FXD 680pF ±5% 100 V CER C0G	02010	SA101A681JAAH
A7C71	0160-4811	1	CAP-FXD 270pF ±5% 100 V CER C0G	02010	SA101A271JAAH
A7C72-C73	0180-4129	1	CAP-FXD 1uF ±10% 35 V TA	04200	173D105X9035V
A7C74	0160-4624	1	CAP-FXD 8200pF ±5% 50 V CER C0G	02010	SA405A822JAAH
A7C75	0160-4820	1	CAP-FXD 1800pF ±5% 100 V CER C0G	02010	SA301A182JAAH
A7C76	0160-4807	1	CAP-FXD 33pF ±5% 100 V CER C0G	02010	SA102A330JAAH
A7CR1 - CR4	1901-0050	4	DIODE-SWITCHING 80V 200MA 2NS DO-35	03406	
A7CR5 - CR8	1901-0535	1	DIODE-SCHOTTKY SM SIG	02062	50825511
A7CR9-CR10	1901-0050	1	DIODE-SWITCHING 80V 200MA 2NS DO-35	03406	
A7CR11 - CR34	1901-0376	24	DIODE-GEN PRP 35V 50MA DO-35	00046	S303
A7E1	9170-0847	1	CORE-SHIELDING BEAD	06337	56-590-65/3BMCD
A7L1-L2	9100-2562	1	INDUCTOR RF-CH-MLD 100UH ±10%	03273	17S103K
A7MP2	4040-0756	2	EXTR-PC BD WHT POLYC .062-IN-BD-THKNS	10456	
A7MP3	1480-0073	2	PIN-ROLL .062-IN-DIA .25-IN-LG BE-CU	04559	99-012-062-0250
A7MP7	08757-20027	1	CONN 1.23x.98INCH		
A7MP8	08757-20026	1	CONN .93x1.18 INCH		
A7P1	1251-7906	1	CONN-POST TYPE .100-PIN-SPCG 36-CONT	01380	534204-3
A7Q1-Q3	1853-0451	1	TRANSISTOR PNP 2N3799 SI TO-18 PD=360MW	02037	ST1468
A7Q4-Q7	1854-0404	1	TRANSISTOR NPN SI TO-18 PD=360MW	02037	SS9333

*Replaceable Parts List for A7, A8, A9, and A10 Assemblies (2 of 4)*

Reference Designation	HP Part Number	Qty	Description	Mfr Code	Mfr Part Number
A7Q8	1854-0753	1	TRANSISTOR-DUAL NPN TO-71 PD=500MW	13127	3218-52
A7Q9	1854-0404	1	TRANSISTOR NPN SI TO-18 PD=360MW	02037	SS9333
A7Q10	1855-0420	1	TRANSISTOR J-FET 2N4391 N-CHAN D-MODE	02883	2N4391
A7Q11-Q12	1854-0907	1	TRANSISTOR NPN 2N2484 TO-18 PD=360MW	02037	ST1603
A7Q13	1854-0404	1	TRANSISTOR NPN SI TO-18 PD=360MW	02037	SS9333
A7R1	0757-0199	1	RESISTOR 21.5K $\pm$ 1% .125W TF TC=0 $\pm$ 100	05524	
A7R2	0698-3447	1	RESISTOR 422 $\pm$ 1% .125W TF TC=0 $\pm$ 100	05524	
A7R4-R5	0757-0199	1	RESISTOR 21.5K $\pm$ 1% .125W TF TC=0 $\pm$ 100	05524	
A7R6	0698-6362	1	RESISTOR 1K $\pm$ 0.1% .125W TF TC=0 $\pm$ 25	05524	
A7R8	0698-3433	1	RESISTOR 28.7 $\pm$ 1% .125W TF TC=0 $\pm$ 100	05524	
A7R9	0698-0085	1	RESISTOR 2.61K $\pm$ 1% .125W TF TC=0 $\pm$ 100	05524	
A7R10-R11	0698-8606	1	RESISTOR 450 $\pm$ 0.1% .125W TF TC=0 $\pm$ 25	05524	
A7R11	0698-8606	1	RESISTOR 450 $\pm$ 0.1% .125W TF TC=0 $\pm$ 25	05524	
A7R12	0698-3433	1	RESISTOR 28.7 $\pm$ 1% .125W TF TC=0 $\pm$ 100	05524	
A7R13	0698-0085	1	RESISTOR 2.61K $\pm$ 1% .125W TF TC=0 $\pm$ 100	05524	
A7R14	0757-0438	1	RESISTOR 5.11K $\pm$ 1% .125W TF TC=0 $\pm$ 100	05524	
A7R15	0698-3153	1	RESISTOR 3.63K $\pm$ 1% .125W TF TC=0 $\pm$ 100	05524	
A7R16	0698-3447	1	RESISTOR 422 $\pm$ 1% .125W TF TC=0 $\pm$ 100	05524	
A7R17-R18	0757-0401	1	RESISTOR 100 $\pm$ 1% .125W TF TC=0 $\pm$ 100	05524	
A7R19	0757-0419	1	RESISTOR 681 $\pm$ 1% .125W TF TC=0 $\pm$ 100	05524	
A7R20-R21	0757-0438	1	RESISTOR 5.11K $\pm$ 1% .125W TF TC=0 $\pm$ 100	05524	
A7R22	0757-0199	1	RESISTOR 21.5K $\pm$ 1% .125W TF TC=0 $\pm$ 100	05524	
A7R23	0698-0083	1	RESISTOR 1.96K $\pm$ 1% .125W TF TC=0 $\pm$ 100	05524	
A7R24	0698-3450	1	RESISTOR 42.2K $\pm$ 1% .125W TF TC=0 $\pm$ 100	05524	
A7R25-R26	0698-3433	1	RESISTOR 28.7 $\pm$ 1% .125W TF TC=0 $\pm$ 100	05524	
A7R27	0698-8756	1	RESISTOR 166.7 $\pm$ 0.1% .125W TF TC=0 $\pm$ 25	05524	
A7R28	0698-6616	1	RESISTOR 750 $\pm$ 0.1% .125W TF TC=0 $\pm$ 25	05524	
A7R29	0698-6364	1	RESISTOR 50 $\pm$ 0.1% .125W TF TC=0 $\pm$ 25	05524	
A7R30	0698-3450	1	RESISTOR 42.2K $\pm$ 1% .125W TF TC=0 $\pm$ 100	05524	
A7R31	0757-0199	1	RESISTOR 21.5K $\pm$ 1% .125W TF TC=0 $\pm$ 100	05524	
A7R32	0698-0083	1	RESISTOR 1.96K $\pm$ 1% .125W TF TC=0 $\pm$ 100	05524	
A7R33-R34	0757-0280	1	RESISTOR 1K $\pm$ 1% .125W TF TC=0 $\pm$ 100	05524	
A7R35-R37	0757-0401	1	RESISTOR 100 $\pm$ 1% .125W TF TC=0 $\pm$ 100	05524	
A7R38-R39	0757-0280	1	RESISTOR 1K $\pm$ 1% .125W TF TC=0 $\pm$ 100	05524	
A7R40	0698-3440	1	RESISTOR 196 $\pm$ 1% .125W TF TC=0 $\pm$ 100	05524	
A7R41-R42	0757-0401	1	RESISTOR 100 $\pm$ 1% .125W TF TC=0 $\pm$ 100	05524	
A7R43	0699-0400	1	RESISTOR 3.6K $\pm$ 0.1% .125W TF TC=0 $\pm$ 25	05524	
A7R44	0698-6362	1	RESISTOR 1K $\pm$ 0.1% .125W TF TC=0 $\pm$ 25	05524	
A7R46	0757-0280	1	RESISTOR 1K $\pm$ 1% .125W TF TC=0 $\pm$ 100	05524	
A7R47	0699-0400	1	RESISTOR 3.6K $\pm$ 0.1% .125W TF TC=0 $\pm$ 25	05524	
A7R48	0698-6362	1	RESISTOR 1K $\pm$ 0.1% .125W TF TC=0 $\pm$ 25	05524	
A7R49-R50	0757-0280	1	RESISTOR 1K $\pm$ 1% .125W TF TC=0 $\pm$ 100	05524	
A7R51-R52	0757-0401	1	RESISTOR 100 $\pm$ 1% .125W TF TC=0 $\pm$ 100	05524	
A7R53	0699-0400	1	RESISTOR 3.6K $\pm$ 0.1% .125W TF TC=0 $\pm$ 25	05524	
A7R54	0698-6362	1	RESISTOR 1K $\pm$ 0.1% .125W TF TC=0 $\pm$ 25	05524	
A7R56	0757-0280	1	RESISTOR 1K $\pm$ 1% .125W TF TC=0 $\pm$ 100	05524	
A7R57	0699-0400	1	RESISTOR 3.6K $\pm$ 0.1% .125W TF TC=0 $\pm$ 25	05524	
A7R58	0698-6362	1	RESISTOR 1K $\pm$ 0.1% .125W TF TC=0 $\pm$ 25	05524	
A7R60	0757-0280	1	RESISTOR 1K $\pm$ 1% .125W TF TC=0 $\pm$ 100	05524	
A7R61-R62	0757-0401	1	RESISTOR 100 $\pm$ 1% .125W TF TC=0 $\pm$ 100	05524	
A7R63	0699-0400	1	RESISTOR 3.6K $\pm$ 0.1% .125W TF TC=0 $\pm$ 25	05524	

*Replaceable Parts List for A7, A8, A9, and A10 Assemblies (3 of 4)*

Reference Designation	HP Part Number	Qty	Description	Mfr Code	Mfr Part Number
A7R64	0698-6362	1	RESISTOR 1K $\pm$ 0.1% .125W TF TC=0 $\pm$ 25	05524	
A7R66	0757-0280	1	RESISTOR 1K $\pm$ 1% .125W TF TC=0 $\pm$ 100	05524	
A7R67	0699-0400	1	RESISTOR 3.6K $\pm$ 0.1% .125W TF TC=0 $\pm$ 25	05524	
A7R68	0698-6362	1	RESISTOR 1K $\pm$ 0.1% .125W TF TC=0 $\pm$ 25	05524	
A7R69	0698-6619	1	RESISTOR 15K $\pm$ 0.1% .125W TF TC=0 $\pm$ 25	05524	
A7R70	0757-0401	1	RESISTOR 100 $\pm$ 1% .125W TF TC=0 $\pm$ 100	05524	
A7R71	0699-1011	1	RESISTOR 3.32K $\pm$ 0.1% .125W TF TC=0 $\pm$ 25	01074	
A7R72	0757-0401	1	RESISTOR 100 $\pm$ 1% .125W TF TC=0 $\pm$ 100	05524	
A7R73	0699-0400	1	RESISTOR 3.6K $\pm$ 0.1% .125W TF TC=0 $\pm$ 25	05524	
A7R74	0757-0401	1	RESISTOR 100 $\pm$ 1% .125W TF TC=0 $\pm$ 100	05524	
A7R75	0698-6362	1	RESISTOR 1K $\pm$ 0.1% .125W TF TC=0 $\pm$ 25	05524	
A7R76	0698-6616	1	RESISTOR 750 $\pm$ 0.1% .125W TF TC=0 $\pm$ 25	05524	
A7R77	0757-0401	1	RESISTOR 100 $\pm$ 1% .125W TF TC=0 $\pm$ 100	05524	
A7R78	0698-7576	1	RESISTOR 217 $\pm$ 0.1% .125W TF TC=0 $\pm$ 25	05524	
A7R79 - R90	0757-0421	12	RESISTOR 825 $\pm$ 1% .125W TF TC=0 $\pm$ 100	05524	
A7R91	0757-0397	1	RESISTOR 68.1 $\pm$ 1% .125W TF TC=0 $\pm$ 100	05524	
A7R92	0757-0447	1	RESISTOR 16.2K $\pm$ 1% .125W TF TC=0 $\pm$ 100	05524	
A7R93	0699-0018	1	RESISTOR 519.62 $\pm$ 0.1% .125W TF TC=0 $\pm$ 25	05524	
A7R94	0757-0438	1	RESISTOR 5.11K $\pm$ 1% .125W TF TC=0 $\pm$ 100	05524	
A7R95	0698-0085	1	RESISTOR 2.61K $\pm$ 1% .125W TF TC=0 $\pm$ 100	05524	
A7R96	0698-4438	1	RESISTOR 3.09K $\pm$ 1% .125W TF TC=0 $\pm$ 100	05524	
A7R97-R98	0757-0438	1	RESISTOR 5.11K $\pm$ 1% .125W TF TC=0 $\pm$ 100	05524	
A7R99	0757-0420	1	RESISTOR 750 $\pm$ 1% .125W TF TC=0 $\pm$ 100	05524	
A7R100	0757-0401	1	RESISTOR 100 $\pm$ 1% .125W TF TC=0 $\pm$ 100	05524	
A7R101	0699-0692	1	RESISTOR 1.4K $\pm$ 0.1% .125W TF TC=0 $\pm$ 25	01074	
A7R102	0757-0401	1	RESISTOR 100 $\pm$ 1% .125W TF TC=0 $\pm$ 100	05524	
A7R103-R104	0698-6320	1	RESISTOR 5K $\pm$ 0.1% .125W TF TC=0 $\pm$ 25	05524	
A7R105	0698-6360	1	RESISTOR 10K $\pm$ 0.1% .125W TF TC=0 $\pm$ 25	05524	
A7R106	0757-0401	1	RESISTOR 100 $\pm$ 1% .125W TF TC=0 $\pm$ 100	05524	
A7R107	0698-6360	1	RESISTOR 10K $\pm$ 0.1% .125W TF TC=0 $\pm$ 25	05524	
A7R108	0757-0401	1	RESISTOR 100 $\pm$ 1% .125W TF TC=0 $\pm$ 100	05524	
A7R109	0698-6360	1	RESISTOR 10K $\pm$ 0.1% .125W TF TC=0 $\pm$ 25	05524	
A7R110	0698-6320	1	RESISTOR 5K $\pm$ 0.1% .125W TF TC=0 $\pm$ 25	05524	
A7R111	0698-6363	1	RESISTOR 40K $\pm$ 0.1% .125W TF TC=0 $\pm$ 25	05524	
A7R112	0698-6353	1	RESISTOR 50K $\pm$ 0.1% .125W TF TC=0 $\pm$ 25	05524	
A7R113-R114	0698-8642	1	RESISTOR 56.2K $\pm$ 0.1% .125W TF TC=0 $\pm$ 25	05524	
A7R115	0698-4473	1	RESISTOR 8.06K $\pm$ 1% .125W TF TC=0 $\pm$ 100	05524	
A7R116-R118	0757-0401	1	RESISTOR 100 $\pm$ 1% .125W TF TC=0 $\pm$ 100	05524	
A7R119-R120	0699-0768	1	RESISTOR 22.6K $\pm$ 0.1% .125W TF TC=0 $\pm$ 25	01074	
A7R121	0698-4438	1	RESISTOR 3.09K $\pm$ 1% .125W TF TC=0 $\pm$ 100	05524	
A7R122	0757-0401	1	RESISTOR 100 $\pm$ 1% .125W TF TC=0 $\pm$ 100	05524	
A7R123	0757-0280	1	RESISTOR 1K $\pm$ 1% .125W TF TC=0 $\pm$ 100	05524	
A7R124-R126	0757-0401	1	RESISTOR 100 $\pm$ 1% .125W TF TC=0 $\pm$ 100	05524	
A7R127 - R130	0757-0199	4	RESISTOR 21.5K $\pm$ 1% .125W TF TC=0 $\pm$ 100	05524	
A7R131-R132	0757-0401	1	RESISTOR 100 $\pm$ 1% .125W TF TC=0 $\pm$ 100	05524	
A7R133-R135	0698-6320	1	RESISTOR 5K $\pm$ 0.1% .125W TF TC=0 $\pm$ 25	05524	
A7R136	0757-0447	1	RESISTOR 16.2K $\pm$ 1% .125W TF TC=0 $\pm$ 100	05524	
A7R137	0757-0199	1	RESISTOR 21.5K $\pm$ 1% .125W TF TC=0 $\pm$ 100	05524	
A7R138	0698-3440	1	RESISTOR 196 $\pm$ 1% .125W TF TC=0 $\pm$ 100	05524	
A7R139	0757-0442	1	RESISTOR 10K $\pm$ 1% .125W TF TC=0 $\pm$ 100	05524	
A7T1	08757-80029	1	TUNED FILT #1		

*Replaceable Parts List for A7, A8, A9, and A10 Assemblies (4 of 4)*

Reference Designation	HP Part Number	Qty	Description	Mfr Code	Mfr Part Number
A7T2	08757-80030	1	TUNED FILT #2		
A7T3	08757-80031	1	TUNED FILT #3		
A7TP1 - TP10	0360-0535	10	CONNECTOR-SGL CONT TML-TS-PT	13296	
A7U1-U3	1826-0547	1	IC OP AMP LOW-BIAS-H-IMP DUAL 8 PIN	01698	TL072ACP
A7U4	1826-0740	1	ANALOG SWITCH 2 SPDT 16 -CERDIP	03799	HI1-5043B3053-011
A7U5	1826-1049	1	IC OP AMP PRCN 8 PIN DIP-C	02180	OP-27GZ
A7U6	1826-1298	1	IC OP AMP GP DUAL 8 PIN DIP-C	02180	OP-14CZ
A7U7	1826-1049	1	IC OP AMP PRCN 8 PIN DIP-C	02180	OP-27GZ
A7U8-U9	1826-0547	1	IC OP AMP LOW-BIAS-H-IMP DUAL 8 PIN	01698	TL072ACP
A7U10	1DK8-0003	1	LOGGER		
A7U11	1826-0547	1	IC OP AMP LOW-BIAS-H-IMP DUAL 8 PIN	01698	TL072ACP
A7U12	1826-1048	1	IC OP AMP PRCN 8 PIN DIP-C	02180	OP-07CZ
A7U13	1826-1298	1	IC OP AMP GP DUAL 8 PIN DIP-C	02180	OP-14CZ
A7VR2	1902-0692	1	DIODE-ZNR 6.3V 1% PD=.4W TC=+.001%	02688	DT790107A
A7VR3-VR4	1902-0048	1	DIODE-ZNR 6.81V 5% DO-35 PD=.4W	02037	SZ30016-1

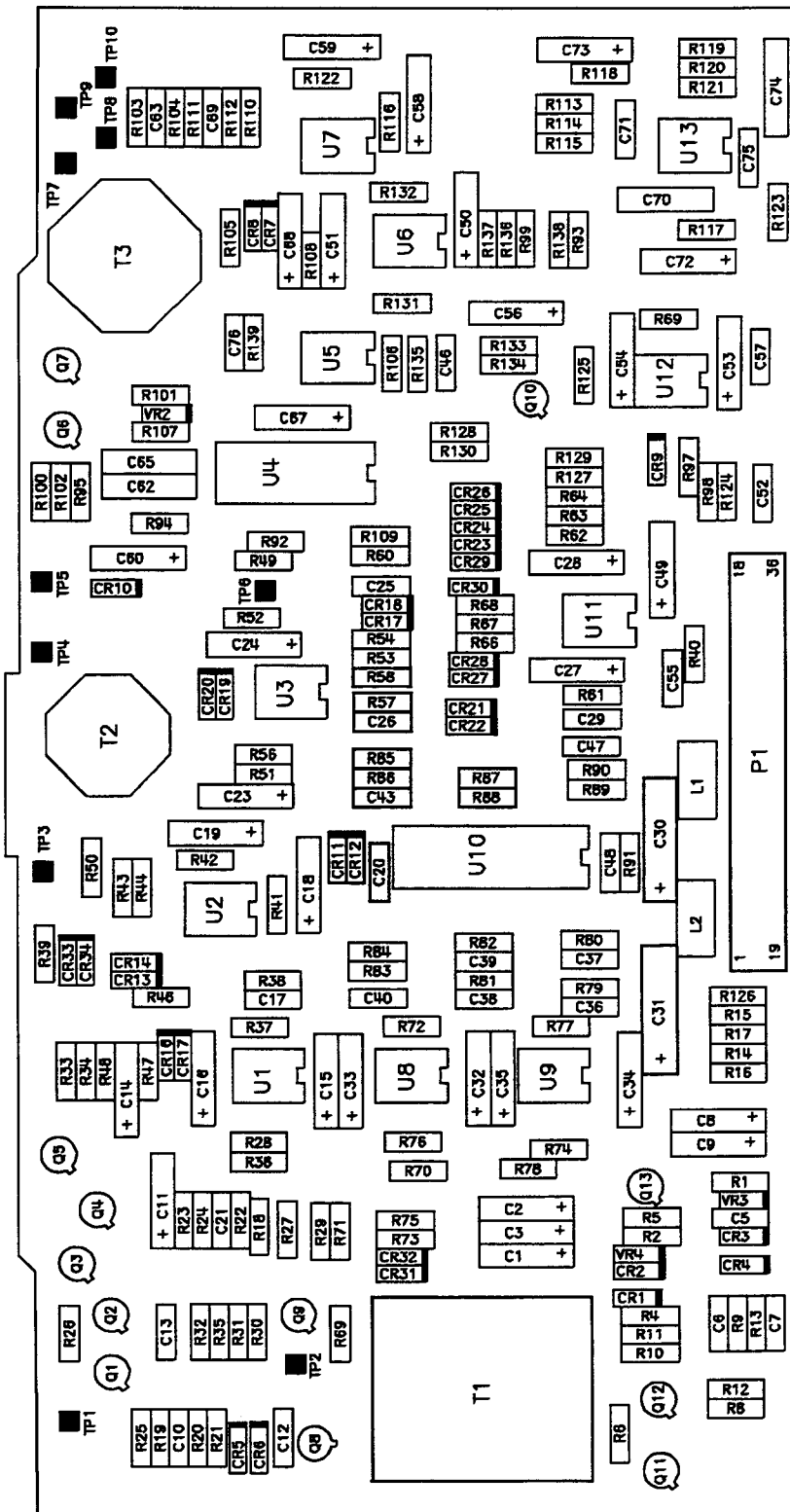
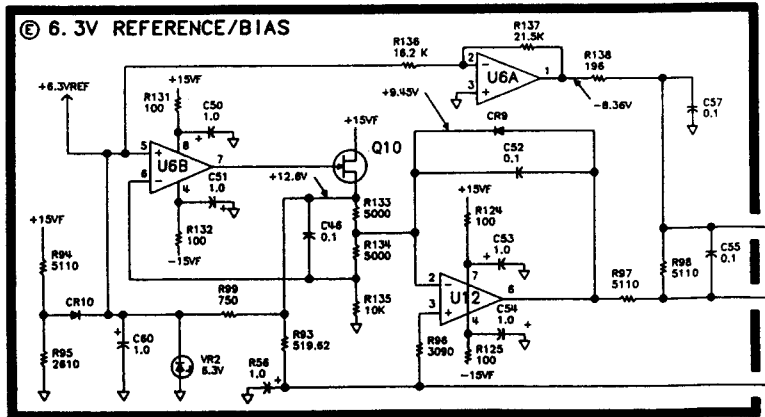
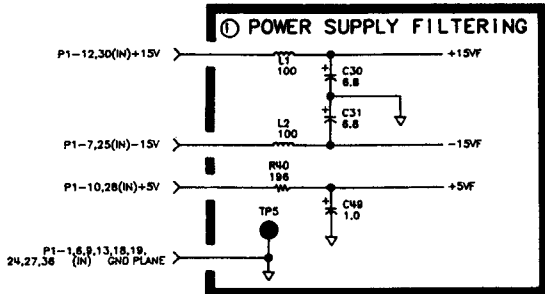
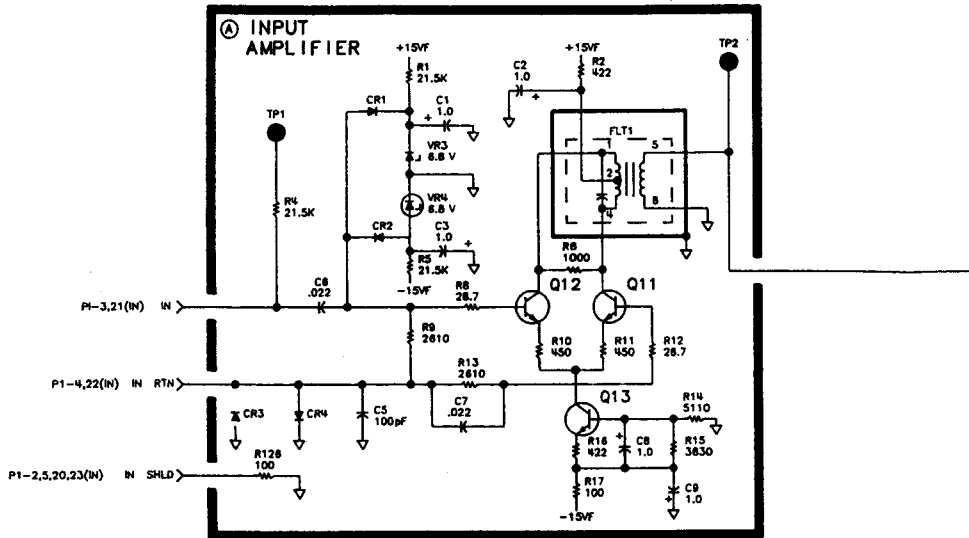


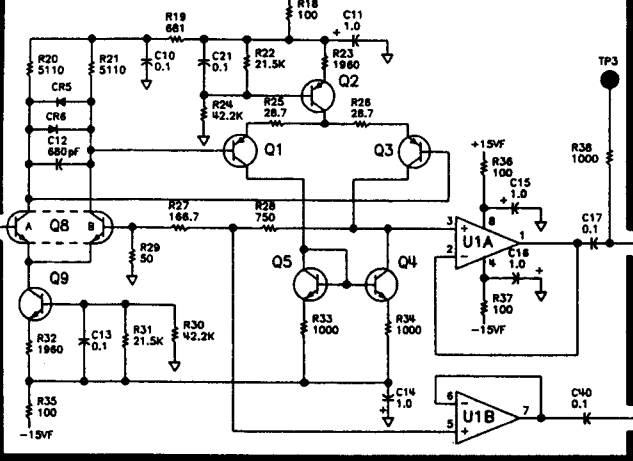
Figure 8-33. A7/A8/A9/A10 Component Locations Diagram



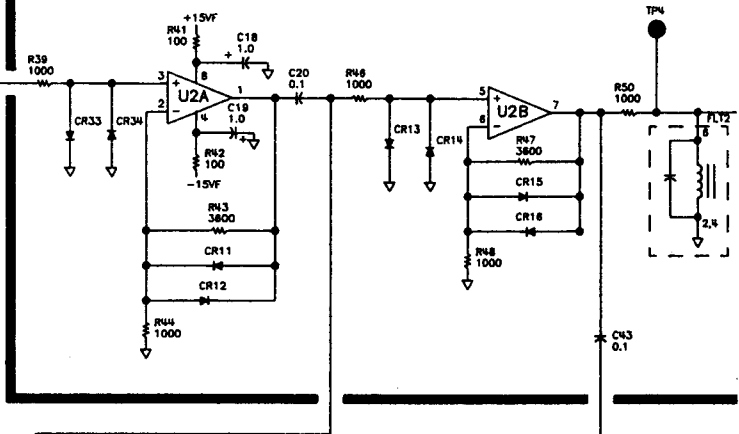
A7/A8/A9/A10 LOG AMPLIFIERS (A/B/C/R) 08757-60087



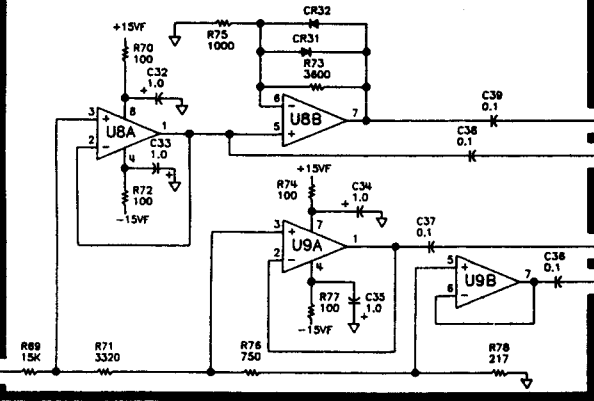
⑩ 13/26dB AMPLIFIER



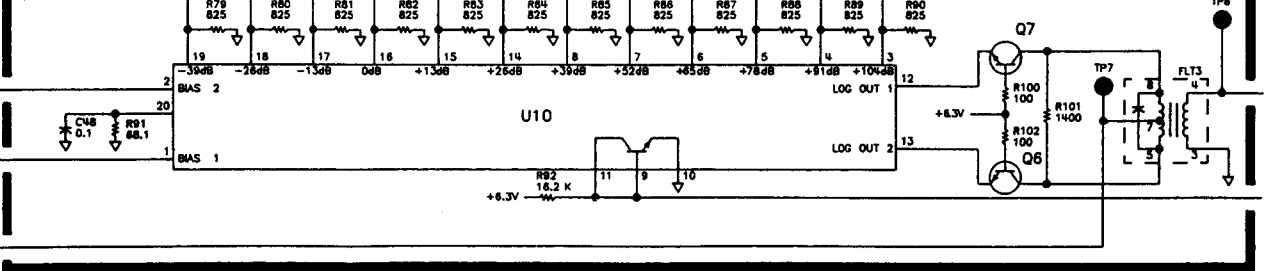
⑪ 13dB GAIN STAGES

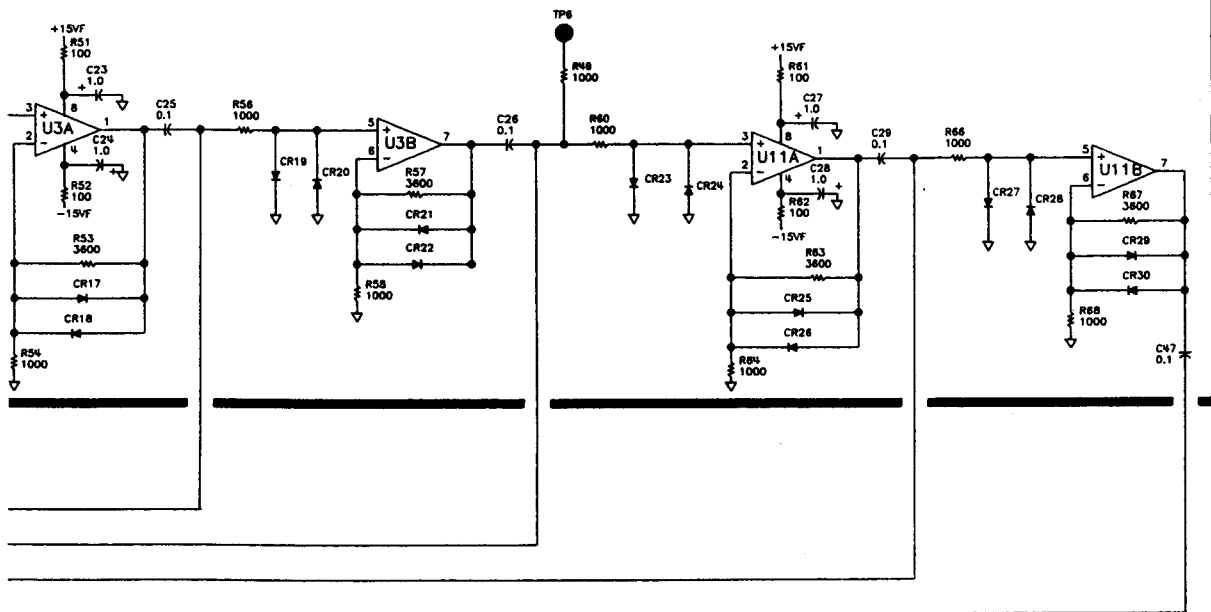


⑫ 13dB ATTENUATION STAGES



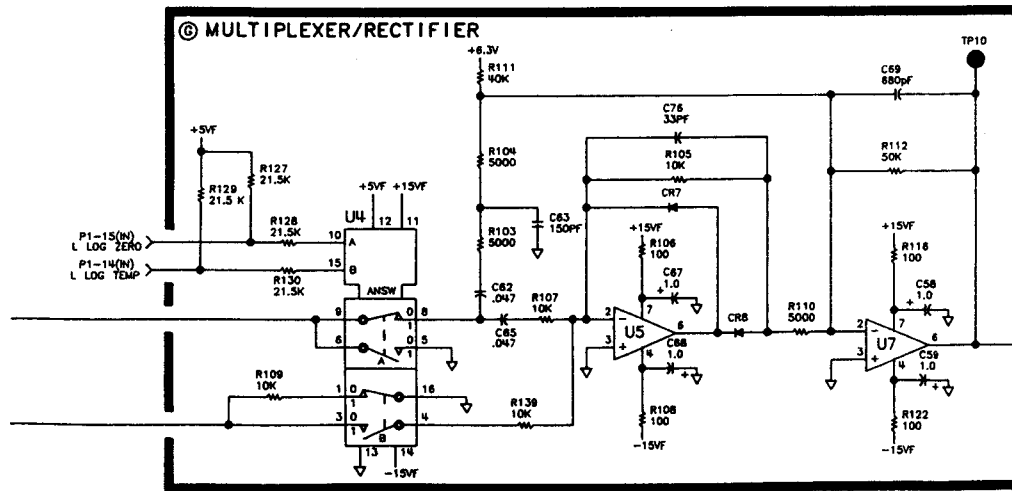
⑬ LOGGER



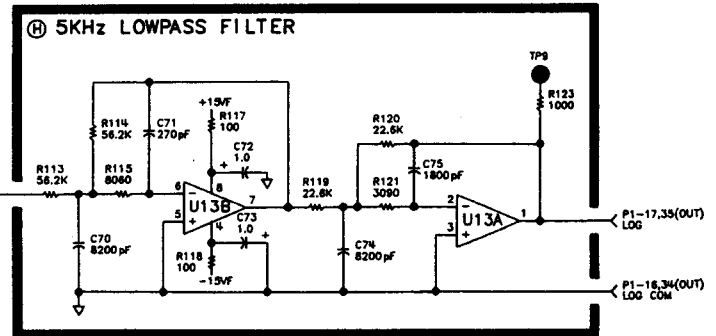


MULTIPLEXER CONTROL		
INPUTS		MEASURE
L LOG TEMP	L LOG ZERO	
0	0	TEMPERATURE
0	1	N/A
1	0	ZERO
1	1	LOGGER

© MULTIPLEXER/RECTIFIER



Ⓢ 5KHz LOWPASS FILTER



# A12 Power Supply

## CIRCUIT DESCRIPTION

This Chapter documents the A12 power supply assembly and the following assemblies:

- Rear panel power line module.
- Front panel line switch.
- Thermal protection switch.
- Transformer.
- The following paragraphs apply to chassis-mounted parts (not part of A12) that are associated with the line power circuits.

## POWER LINE MODULE FL1, LINE SWITCH S1, THERMAL SWITCH S2, TRANSFORMER T1

The power line module includes the primary fuse, line filter, and voltage selector. Fuse F1 protects the primary side of the transformer against drawing too much current. F1 is accessible from the rear panel. The line filter reduces noise and transients on the power line.

The front panel LINE power on/off switch S1 controls power to the transformer primary coil. Thermal protection switch S2 protects the regulators from thermal damage if the fan fails or air flow is restricted. S2 is thermally connected to the regulator heat sink (part of A12), and opens at about 90°C to interrupt the line power. S2 closes again when the temperature falls below about 70°C.

The voltage selector configures the instrument to run on 100 V ac, 120 V ac, 220 V ac, or 240 V ac line power. The voltage is selected by inserting the voltage selector card into FL1 at the rear panel in one of four orientations. This effectively switches in or out the various taps of the transformer primary windings.

The transformer secondary consists of three center-tapped windings. The nine wires from the secondary connect directly to the A12 power supply assembly.

**NOTE:** The following paragraphs apply to the A12 power supply assembly. All reference designators apply to A12.

The A12 power supply provides the regulated power supply voltages for all assemblies in the instrument. There are six independent regulated voltages in all, of which two supply power to the A14/A15 display assembly exclusively. Table 8-26 summarizes the power supplies provided. A power failure detection circuit senses when line power is removed, to allow an orderly shut-down of digital circuitry on the A3 CPU assembly. An additional power supply failure circuit monitors all supplies (except +5 V) and signals the microprocessor if any supply has failed or is substantially low in value.

## A. +5V RECTIFIER

CR29 (two diodes) is the full-wave rectifier for the +5 V dc supplies. C25 and C26 filter the full-wave ripple from CR29. C21 is a low impedance path for high frequency pulses. Bleeder resistor R73 discharges C25 and C26 when line power is removed. C19 and C20 prevent the rectifier switching pulses from getting back to the transformer secondary. The +5 V rectifier output is nominally +10 V dc before regulation.

## B. OVERVOLTAGE PROTECTION

The overvoltage protection blows the line fuse F1 to protect the instrument from excessive line voltages. It also blows fuse F1 if the voltage selector is set to 100 V ac or 120 V ac and the line is connected to 220 V ac or 240 V ac in error. If the unregulated voltage from the +5 V rectifier exceeds +18.6 V dc, zener diodes VR19, VR20, and VR21 conduct, turning SCR Q1 on through R76. Q11 causes excessive current to flow in the transformer, which causes line fuse F1 to blow. R75 holds Q1 off unless VR19, VR20, and VR21 are conducting. C23 prevents short transients or noise from firing Q1.

**NOTE:** Five of the six regulator circuits on the A12 power supply assembly are of the same design (+65 V is different). While component values differ slightly for different voltages, and diode and capacitor polarities change for different polarities, the circuits are essentially identical. The +5V regulator is described in detail. For other regulator description details, refer back to the +5V regulator description.

## C. +5V REGULATOR

The +5V regulator regulates the +10 V dc from the +5V rectifier to produce the +5 V dc power supply voltage. Fuse F6 prevents excessive currents from destroying the regulator in case of an accidental short circuit. The fuse can also be removed during troubleshooting to isolate the +5V regulator from the +5V rectifier. U1 is an adjustable, three-terminal regulator. Its output voltage is nominally 1.25 V dc above the voltage on reference terminal U1 pin 1. R1 and the series combination of R38 and R37 determine the regulated output voltage. C36 improves power line ripple and noise rejection, and also causes the power supply voltage to rise slowly and without overshoot. The adjustable terminal voltage on U1 pin 1 is accessible at a PC pad (not a test point) labeled "1R". Input bypass capacitor C1 reduces high frequency noise or transients into the regulator. C35 and C11 reduce noise at the output. CR1 provides a safe discharge path for C35 when the regulator input voltage falls below the output voltage. CR14 and CR1 provide safe discharge paths for C36 if either input or output voltage falls below the adjustable terminal voltage. CR13 protects the regulator from negative voltages at the output.

The crowbar circuit provides overvoltage protection for circuits fed by the +5V regulator if U1 or CR1 is shorted. If the output voltage rises above 5.9 V dc, zener diode VR11 conducts and fires SCR Q6 through R43. This shorts the output to ground and blows fuse F6, shutting down that power supply. R42 holds Q6 off unless VR11 conducts.

Test point TP4 (+5V DIG) is available to monitor the output voltage. R40 limits the current if the test point is shorted. LED DS2 turns on when the output voltage is about +4 V dc or greater. VR10 sets the voltage at which DS2 lights. R39 limits the current through DS2. R37 adjusts the output voltage at TP4. Note that the LED, test point, and adjustment are physically located near each other on the board and share the label +5V DIG.

A single regulator controls both the +5V DIG and +5V supplies. However, they exit the board on separate pins and follow independent paths to the rest of the instrument.

#### **D. +5V REGULATOR (DISPLAY)**

The +5V regulator (display) supplies the +5 V dc power supply voltage for the A14 display interface board. R44 (+5V DSP) adjusts this output voltage at TP5. This circuit is identical to the +5V regulator.

#### **E. POWER FAILURE WARNING**

The power failure warning circuit detects when the line power has been switched off or removed and power supply voltages are about to go down. It sends a warning signal to the A3 CPU to prevent data from being lost during shut-down. The inverting input of comparator U5 is biased at about +3 V dc by R35 and R36 from the output of the +5V regulator. The non-inverting input of U5 is biased by R33 and R34 from the input of the +5V regulator. The unregulated input is normally about +10 V dc, setting U5 pin 2 at +3.8 V dc and L PFW high. When the +5V regulator input falls below about +8 V dc, U5 turns on and pulls L PFW low. R31 is a pull-up resistor for U5. R32 provides hysteresis for noise immunity. C12 holds L PFW low as U5 turns off.

#### **F. ±15V RECTIFIER**

The ±15V rectifier rectifies one of the center-tapped transformer secondary windings with two full-wave rectifiers of opposite polarity. CR27 and CR28 provide +15V UNREG (nominally +23 V dc); CR26 and CR30 provide -15V UNREG (nominally -23 V dc). C31 and C32 filter the line ripple. Bleeder resistors R25 and R77 discharge C31 and C32 respectively when line power is removed. C28 and C22 filter noise and transients from the diodes. C24 and C27 prevent rectifier switching transients from reaching the transformer. Fuse F8 limits current to the DC fan which operates from the -15 V unregulated supply.

#### **H. +15V REGULATOR**

The +15V regulator provides +15 V dc regulated power supply voltage for all of the instrument. R51 (+15V) adjusts this output voltage at TP6. Except for the difference in voltage, the +15V regulator is identical to the +5V regulator: refer to the +5V circuit description for details.

## J. +65V RECTIFIER

The +65V rectifier rectifies transformer secondary winding with a full-wave bridge rectifier. CR31–34 provides the +65V UNREG supply (nominally +90 Vdc). C45 and C46 filter the line ripple. Bleeder resistor R15 discharges these capacitors when line power is removed. C38 filters noise and transients from the diodes. C13 prevents rectifier switching transients from reaching the transformer.

## K. +65 REGULATOR

**NOTE:** The LCD display does not use the +65 volt supply.

The +65V regulator is a non-adjustable supply used *only* for the A15 display. It incorporates two over-current sensors, an over-voltage sensor, and built-in voltage reference. The voltage reference is designed to keep this supply within 0.4 V of +65 V. The supply is not adjustable and must never be modified to exceed +65 V in order to prevent any X-ray radiation from the CRT.

VR1 and Q4 form a constant current source that drives the darlington pair Q10 and Q1. The +65 V output of Q1 is fed through a current sensing resistor R9 and then off the board to the display. Feedback is provided by a resistor divider consisting of R5–6, and R10. The feedback voltage is chosen to be exactly 10 V. This 10 V is compared (by U3) to the independent 10.00 V reference supplied by U4. Any error voltage will drive Q5, thus "stealing" more or less current (through CR11) from the darlington pair Q10/ Q1 and changing the output voltage accordingly. Because Q5 inverts the drive from U3, the negative feedback from the voltage divider is applied to the non-inverting input of U3 instead of the more expected inverting input. VR7 sets the bias on Q5 so that U3's output voltage will be near its midway point of +8 V. Voltage sensing of both the +65 V and the ground is performed so that the supply *at the display* will be +65 V, independent of any voltage drops in the cabling. Resistors R16 and R8 limit the amount of correction for voltage change.

Over-voltage protection is provided by VR2–4. If the voltage should exceed about 75 V, these diodes will turn on Q2. This shorts the unregulated supply to ground and blows fuse F7.

Over-current protection is provided by two methods. One method is very fast but not very accurate; the other is very accurate but takes slightly longer to engage. If the current through R9 should exceed about 0.7 amp, the voltage across it will turn on Q3 which robs current drive to the darlington pair and reduces the output voltage. This circuit works very quickly but is very dependent upon the characteristics of Q3 and its temperature. At the same time, the voltage across R9 is divided down by R16 and R17. This voltage is then compared to an internal 0.2 V reference developed in U2. If the voltage drop across R9 is great enough, U2 will turn on and steal current from the darlington pair. U2 generates a 0.2 V reference between pins 3 and 4 of U2 but *all* pins of U2 are floating at about +65 V. The supply for U2 is only about 2 V and is provided via the three diode drops between pin 7 and pin 4 of U2, through CR7, Q10, and Q1. Again, these are floating at +65 V.

A +17 V power supply is made up of VR6, and R19 and is used to supply bias to U3 and U4. LED DS1 will light when the supply voltage is at least 50 V as determined by VR8 and VR9. The +65 V is available at TP3.



**TP3 (+65V) has no series current limiting resistor. Use care to ensure the testpoint is not shorted to ground or any other point on the board. While a momentary short circuit will not harm the instrument, excessive heat will be generated and Q1 will be destroyed if this testpoint is shorted for extended periods of time.**

## **L. SUPPLY FAILURE INDICATOR**

This circuit monitors all the power supplies except the +5V DIG. A failure of any one or more supplies will be reported to the microprocessor via the L SPLYFAIL line. This circuit will also indicate a failure if any supply fails to reach at least 80% of its nominal value.

The circuit consists of comparator U6 and two voltage divider circuits. All the positive supplies are summed together and divided by R72. The negative supplies are summed together and offset by R41 which is tied to the +5V DIG supply. The summing resistors are chosen to place nominal 2.25 V at the non-inverting input of U6 and a nominal 2.10 V at the inverting input. A failure of any positive or negative supply will cause the inverting input voltage to exceed the non-inverting input voltage. This will cause open-collector U6 to turn on, pulling L SPLYFAIL low. C17 provides noise immunity and R70 provides hysteresis. The status of this line is available at TP2. All supply voltages must be accurately adjusted (including the +5V DIG) in order for this circuit to perform properly.

## **M. —15V REGULATOR**

The —15V regulator provides the regulated —15 V dc power supply voltage for all of the instrument. R58 (—15V) adjusts this output voltage at TP7. Except for the difference in voltage and the opposite polarity, the —15V regulator is identical to the +5V regulator. Refer to the +5V circuit description for details.

## **N. —12.6V REGULATOR**

The —12.6V regulator provides the regulated —12.6 V dc power supply voltage for the instrument. The —12.6V regulator uses the regulated —15 V dc output to produce —12.6 V dc, therefore no fuse or crowbar circuit is required. In addition, the ripple rejection capacitor C18 is smaller, so no discharge diode is needed. Wire jumper W1 can be removed to isolate the —12.6V regulator during troubleshooting. R65 (—12.6) adjusts this output voltage at TP8. The —12.6 V supply is used to bias external detectors, and is therefore critical to instrument accuracy. Except for the difference in voltage and the opposite polarity, the —12.6 V regulator is identical to the +5V regulator. Refer to the +5V circuit description for details.



## **P. GROUNDS**

The grounds for all six regulators share a common star ground. This ground is attached to the instrument chassis (GNDCH) with sheet metal and hardware. Although connected electrically on the A12 power supply assembly, independent paths for several grounds reduce ground loop noise. GND is the general purpose ground for the instrument. GNDDIG is the high-current ground for digital circuits. GNDA is a special low-current, noise-free ground used for sensitive analog circuits. GND DISP is the ground return for the A14 display interface power supplies.

## A12 Troubleshooting

This Chapter documents the A12 power supply assembly and the following assemblies:

- Rear panel power line module FL1.
- Front panel line switch S1.
- Thermal protection switch S2.
- Transformer T1.

### BASIC CHECKS

Check that the rear panel line filter voltage selection card is selected for the correct line voltage. Check that line fuse F1 is good, and is the correct fuse for the line voltage.

### LINE POWER

Turn on the line switch, and check that the fan is rotating. If not, check the line fuse F1 and the fan fuse F8. Check the thermal switch S2 (mounted on the A12 heat sink), and replace it if necessary.

### TRANSFORMER

Check the outputs of transformer T1 on the A12 power supply. Check E1 for approximately 19 V ac. Check E2 for approximately 38 V ac. Check E3 for approximately 72 V ac. These are all measured across the entire windings of each transformer Chapter. The voltage will be one half if measured with respect to ground. If any of these is missing, trace the problem back to transformer T1.

### RECTIFIERS

Check the output of the +5V rectifier for approximately +10 V. Check the output of the  $\pm 15$ V rectifier for approximately  $\pm 20$  V. Check the output of the +65V rectifier for approximately +90 V. If one of these voltages is missing, suspect the corresponding rectifier. Check that the overvoltage protection is not firing.

### ADJUSTABLE REGULATORS

Check all the fuses on the A12 power supply assembly. These fuses may be removed to disconnect the regulators from the rectifiers for troubleshooting.

To verify the voltage regulators, check that the voltage difference between the output and regulation (adjust) terminals is approximately 1.25 V. The regulator (adjust) terminals are available at feedthrough holes (not test points) on the A12 power supply assembly.

To eliminate the possibility of other assemblies in the instrument loading down the supply voltages, remove the major assemblies from their connectors (including the A14 display power supply and the front panel cables), or pull up the A12 power supply assembly so that it is disconnected from the motherboard.

## K. +65 REGULATOR

**NOTE:** The LCD display does not use the +65 volt supply.

First disconnect the A16 display, then apply power. If the supply returns to normal, verify that the current draw of the display is a nominal 300 mA. If it is substantially more than this, a problem with the display is indicated.

If fuse F7 blows, temporarily remove R20 (with the display still disconnected.) Verify +17 and +10.00 V at the test pads indicated on the board. The 17 V supply should develop about 6.3 mA through Q4. Verify this by measuring about 2.4 V across R15. Verify that the voltage at U2 pin 2 is less than that at pin 3 and that the voltage drop across R9 is less than a few millivolts. The voltage between R5 and R6 should be 10/65 of the TP3 value. Follow the feedback path through U3, Q5, CR11, Q10 and Q1 to isolate any possible opens or shorts. Pins 2 and 3 of U3 should have identical voltages (+10 V) if the feedback loop is operating properly. The output of U3 should be about +8 V. Also verify the proper voltage drop across VR2–4 if there is a problem with the fuse blowing (although under normal conditions there will be insufficient voltage to turn on all three zeners.)

If the supply voltage is low and the reference voltages are good, the constant current source from Q4 to Q10 could be diverted by either Q3 or U2. Temporarily remove CR5 or Q3 to verify this. Make sure the display is not connected during this time.

Refer to Table 8–26 for power supply voltages and tolerances.

*Table 8–26. Power Supply Voltages and Tolerances*

Block	Power Supply Voltage	Nominal Voltage	Allowable Range (Vdc)	Maximum Current Drain (A)	Assemblies Where Used
C	+5V <sup>1</sup>	+5.1	+5.05/+5.15	2.6	A1/A2 through A10
D	+5V DISP	+5.1	+5.05/+5.15	2.0	A14, A16
H	+15V	+15	+14.95/+15.05	0.6	A2 (for external detectors) A4, A5, A7, A8, A9, A10
M	–15V	–15	–14.95/–15.05	0.3	A4, A5, A7, A8, A9, A10
N	+12.6V <sup>2</sup>	–12.6	–12.55/–12.65	0.3	A2 (for external detectors)
K	+65V	+65.0	+64.6/+65.4	0.5	A15 (CRT only)

1. Includes both +5V and +5VDIG supplies.

2. The –12.6V supply is derived from the –15V supply with an additional regulator.

**Replaceable Parts List for A12 Assembly (1 of 4)**

Reference Designation	HP Part Number	Qty	Description	Mfr Code	Mfr Part Number
A12	06757-60102	1	BD AY-PWR SUPPLY	28480	06757-60102
A12C1 - C4	0180-4129	3	CAP-FXD 1uF ±10% 35 V TA	04200	173D105X9035V
A12C5	0160-4386	1	CAP-FXD 33pF ±5% 200 V CER C0G	09939	RPE121-105C0G330J200V
A12C6	0160-0161	1	CAP-FXD 0.01uF ±10% 200 V POLYE-FL	05176	HEW238T
A12C7	0160-5755	1	CAP-FXD 0.1uF ±10% 100 V CER X7R	02010	SA401C104KAAH
A12C8	0180-2211	1	CAP-FXD 4.7uF ±20% 160 V AL-ELCTLT	00493	SME160T4R7M8X16TP
A12C9	0160-0168	1	CAP-FXD 0.1uF ±10% 200 V POLYE-FL	05176	HEW238T
A12C10	0160-4574	1	CAP-FXD 1000pF ±10% 100 V CER X7R	02010	SA101C102KAAH
A12C11	0160-2055	1	CAP-FXD 0.01uF +80% -20% 100 V CER Y5V	09538	805-504 Y5V 103Z
A12C12	0180-3849	1	CAP-FXD 47uF ±10% 10 V TA	04200	299D476X9010DB1
A12C13	0160-0168	1	CAP-FXD 0.1uF ±10% 200 V POLYE-FL	05176	HEW238T
A12C14	0160-4832	1	CAP-FXD 0.01uF ±10% 100 V CER X7R	02010	SA101C103KAAH
A12C15-C16	0180-3831	1	CAP-FXD 10uF ±10% 35 V TA	04200	299D106X9035DB1
A12C17	0160-4832	1	CAP-FXD 0.01uF ±10% 100 V CER X7R	02010	SA101C103KAAH
A12C18	0180-3831	1	CAP-FXD 10uF ±10% 35 V TA	04200	299D106X9035DB1
A12C19-C20	0160-5708	1	CAP-FXD 0.33uF ±5% 100 V POLYE-MET	05466	150/0.33/J/100/EB
A12C21-C22	0160-2055	1	CAP-FXD 0.01uF +80% -20% 100 V CER Y5V	09538	805-504 Y5V 103Z
A12C23	0180-3713	1	CAP-FXD 2.2uF ±10% 25 V TA	04200	173D225X9025V
A12C24	0160-5708	1	CAP-FXD 0.33uF ±5% 100 V POLYE-MET	05466	150/0.33/J/100/EB
A12C25-C26	0180-4073	1	CAP-FXD +30% -10% 25 V AL-ELCTLT	04200	80D173P025MD2B
A12C27	0160-5708	1	CAP-FXD 0.33uF ±5% 100 V POLYE-MET	05466	150/0.33/J/100/EB
A12C28	0160-2055	1	CAP-FXD 0.01uF +80% -20% 100 V CER Y5V	09538	805-504 Y5V 103Z
A12C29-C30	0180-4132	1	CAP-FXD 6.8uF ±10% 35 V TA	04200	173D685X9035X
A12C31-C32	0180-4071	1	CAP-FXD 7400uF +30% -10% 50 V AL-ELCTLT	04200	80D742P050MD2B
A12C33	0180-4132	1	CAP-FXD 6.8uF ±10% 35 V TA	04200	173D685X9035X
A12C34-C35	0180-4134	1	CAP-FXD 22uF ±10% 15 V TA	04200	173D226X9015X
A12C36-C37	0180-4168	1	CAP-FXD 47uF ±10% 20 V TA	12340	T322E476K020AS
A12C38	0160-0161	1	CAP-FXD 0.01uF ±10% 200 V POLYE-FL	05176	HEW238T
A12C45-C46	0180-4072	1	CAP-FXD 1000uF +30% -10% 200 V AL-ELCTLT	04200	80D102P200MD2B
A12CR1-CR4	1901-0731	1	DIODE-PWR RECT 400V 1A	02037	1N4004
A12CR5-CR8	1901-0033	1	DIODE-GEN PRP 180V 200MA DO-35	03406	
A12CR9-CR10	1901-0731	1	DIODE-PWR RECT 400V 1A	02037	1N4004
A12CR11-CR12	1901-0033	1	DIODE-GEN PRP 180V 200MA DO-35	03406	
A12CR13 - CR20	1901-0731	8	DIODE-PWR RECT 400V 1A	02037	1N4004
A12CR21	1901-0518	1	DIODE-SCHOTTKY SM SIG	02062	5082-5509
A12CR22 - CR24	1901-0731	3	DIODE-PWR RECT 400V 1A	02037	1N4004
A12CR25	1901-0200	1	DIODE-PWR RECT 100V 1.5A	02037	SR1846-00
A12CR26 - CR28	1901-0662	3	DIODE-PWR RECT 100V 6A	02037	MR751
A12CR29	1906-0269	1	DIODE-CT-RECT 40V 10.8A	03038	12CTQ040
A12CR30	1901-0662	1	DIODE-PWR RECT 100V 6A	02037	MR751
A12CR31 - CR34	1901-0767	4	DIODE-PWR RECT 400V 6A	02037	MR754
A12DS1 - DS6	1990-0678	6	LED-LAMP LUM-INT=800UCD IF=30MA-MAX	01542	HLMP-6500 (SEL)
A12E1 - E3	0360-2341	3	TERMINAL BLOCK 3-TERM SCREW POLYA	11170	1713037
A12F2 - F4, F8	2110-0001	1	FUSE (INCH) 1A 250V NTD FE UL	04703	312 001
A12F6	2110-0055	1	FUSE (INCH) 4A 250V NTD FE UL	04703	312 004
A12F7	2110-0043	1	FUSE (INCH) 1.5A 250V NTD FE UL	04703	312 01.5
A12F5	2110-0010	1	FUSE (INCH) 5A 250V NTD FE UL	04703	
A12J1	1252-2797	1	CONN-POST TYPE .100-PIN-SPCG 10-CONT	02946	69168-110
A12J2	1252-2919	1	CONN-POST TYPE .156-PIN-SPCG 15-CONT	03394	3107-1-115-07
A12J3	1251-6932	1	CONN-POST TYPE 2.5-PIN-SPCG 3-CONT	03418	22-11-1031
A12MP2	2110-0643	6	FUHLR-CLP-TYP 15A 250V	09694	FH-8000

**Replaceable Parts List for A12 Assembly (2 of 4)**

Reference Designation	HP Part Number	Qty	Description	Mfr Code	Mfr Part Number
A12MP4	0515-1348	3	SCREW-MACH M3 X 0.5 6MM-LG PAN-HD	06691	DIN7985
A12MP5	0570-0647	10	STD-PRS-IN M3 X 0.5 15.000 PH-BRZ	03981	KFH-M3-15-ET
A12MP6	08757-20072	1	HEAT SINK		
A12MP7	3050-1186	10	WASHER-SHLDR NO. 4 .125-IN-ID .25-IN-OD	05313	
A12MP9	0340-1114	5	INSULATOR-XSTR THRM-CNDCT	05447	K-4-05
A12MP10	0535-0031	10	NUT-HEX W/LKWR M3 X 0.5 2.4MM-THK	06691	
A12MP11	0380-1247	2	SPACER-RVT-ON 8-MM-LG 3.8-MM-ID	02121	
A12MP13	0340-1216	3	INSULATOR-XSTR KAPTON	05447	K10-AC-54
A12MP16	1400-1450	1	CLAMP-CABLE .75-DIA .25-WD NYL	01924	220-242400-07-0101
A12MP17	0380-2011	2	SPACER-SNP-IN .75-IN-LG NYL NAT	01924	215-150912-04-01
A12Q1	1854-1162	1	TRANSISTOR NPN SI TO-204AA PD=250W	02037	MJ15024
A12Q2	1884-0344	1	THYRISTOR-SCR VRRM=400	02037	SCR2143
A12Q3	1854-0477	1	TRANSISTOR NPN 2N2222A SI TO-18 PD=500MW	02037	2N2222A
A12Q4	1859-0221	1	TRANSISTOR PNP 2N5416 SI TO-5 PD=1W	03171	2N5416
A12Q5	1854-0234	1	TRANSISTOR NPN 2N3440 SI TO-5 PD=1W	02037	2N3440
A12Q6-Q9	1884-0344	1	THYRISTOR-SCR VRRM=400	02037	SCR2143
A12Q10	1854-0749	1	TRANSISTOR NPN SI TO-220AB PD=30W	02037	MJE2361-T
A12Q11	1884-0344	1	THYRISTOR-SCR VRRM=400	02037	SCR2143
A12R1	0757-0418	1	RESISTOR 619 ±1% .125W TF TC=0±100	05524	
A12R2-R3	0757-0416	1	RESISTOR 511 ±1% .125W TF TC=0±100	05524	
A12R4	0757-0418	1	RESISTOR 619 ±1% .125W TF TC=0±100	05524	
A12R5	0698-6360	1	RESISTOR 10K ±0.1% .125W TF TC=0±25	05524	
A12R6	0698-6320	1	RESISTOR 5K ±0.1% .125W TF TC=0±25	05524	
A12R7	0698-6353	1	RESISTOR 50K ±0.1% .125W TF TC=0±25	05524	
A12R8	0757-0346	1	RESISTOR 10 ±1% .125W TF TC=0±100	05524	
A12R9	0811-1079	1	RESISTOR .68 ±5% 3W PWI TC=0±90	05524	
A12R10	0757-0422	1	RESISTOR 909 ±1% .125W TF TC=0±100	05524	
A12R11-R12	0698-3446	1	RESISTOR 383 ±1% .125W TF TC=0±100	05524	
A12R13	0698-3428	1	RESISTOR 14.7 ±1% .125W TF TC=0±100	05524	
A12R14	0757-0422	1	RESISTOR 909 ±1% .125W TF TC=0±100	05524	
A12R15	0698-3446	1	RESISTOR 383 ±1% .125W TF TC=0±100	05524	
A12R16	0757-0346	1	RESISTOR 10 ±1% .125W TF TC=0±100	05524	
A12R17	0698-0083	1	RESISTOR 1.96K ±1% .125W TF TC=0±100	05524	
A12R18	0757-0279	1	RESISTOR 3.16K ±1% .125W TF TC=0±100	05524	
A12R19	0764-0020	1	RESISTOR 5.6K ±5% 2W MO TC=0±200	02499	
A12R20	0757-0346	1	RESISTOR 10 ±1% .125W TF TC=0±100	05524	
A12R21	0698-3444	1	RESISTOR 316 ±1% .125W TF TC=0±100	05524	
A12R22	0757-0422	1	RESISTOR 909 ±1% .125W TF TC=0±100	05524	
A12R23	0698-3441	1	RESISTOR 215 ±1% .125W TF TC=0±100	05524	
A12R24	0764-0018	1	RESISTOR 4.7K ±5% 2W MO TC=0±200	02499	
A12R25	0698-3406	1	RESISTOR 1.33K ±1% .5W TF TC=0±100	05524	
A12R27-R28	0757-0418	1	RESISTOR 619 ±1% .125W TF TC=0±100	05524	
A12R29	0699-0272	1	RESISTOR 75K ±0.1% .125W TF TC=0±25	05524	
A12R30	0757-0280	1	RESISTOR 1K ±1% .125W TF TC=0±100	05524	
A12R31	0757-0442	1	RESISTOR 10K ±1% .125W TF TC=0±100	05524	
A12R32	0698-8827	1	RESISTOR 1M ±1% .125W TF TC=0±100	05524	
A12R33	0757-0279	1	RESISTOR 3.16K ±1% .125W TF TC=0±100	05524	
A12R34	0698-0083	1	RESISTOR 1.96K ±1% .125W TF TC=0±100	05524	
A12R35	0757-0279	1	RESISTOR 3.16K ±1% .125W TF TC=0±100	05524	
A12R36	0698-3155	1	RESISTOR 4.64K ±1% .125W TF TC=0±100	05524	
A12R37	2100-0554	1	RESISTOR-TRMR 500 10% TKF TOP-ADJ 1-TRN	03744	

**Replaceable Parts List for A12 Assembly (3 of 4)**

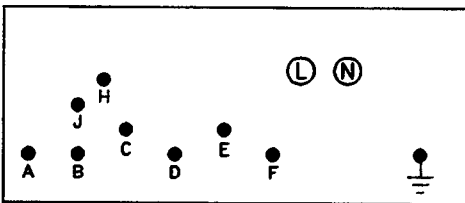
Reference Designation	HP Part Number	Qty	Description	Mfr Code	Mfr Part Number
A12R38	0757-0278	1	RESISTOR 1.78K ±1% .125W TF TC=0±100	05524	
A12R39	0757-0316	1	RESISTOR 42.2 ±1% .125W TF TC=0±100	05524	
A12R40	0757-0280	1	RESISTOR 1K ±1% .125W TF TC=0±100	05524	
A12R41	0698-8911	1	RESISTOR 1.3K ±0.1% .125W TF TC=0±25	05524	
A12R42	0698-3444	1	RESISTOR 316 ±1% .125W TF TC=0±100	05524	
A12R43	0757-0346	1	RESISTOR 10 ±1% .125W TF TC=0±100	05524	
A12R44	2100-0554	1	RESISTOR-TRMR 500 10% TKF TOP-ADJ 1-TRN	03744	
A12R45	0757-0278	1	RESISTOR 1.78K ±1% .125W TF TC=0±100	05524	
A12R46	0757-0316	1	RESISTOR 42.2 ±1% .125W TF TC=0±100	05524	
A12R47	0757-0280	1	RESISTOR 1K ±1% .125W TF TC=0±100	05524	
A12R48	0698-6320	1	RESISTOR 5K ±0.1% .125W TF TC=0±25	05524	
A12R49	0698-3444	1	RESISTOR 316 ±1% .125W TF TC=0±100	05524	
A12R50	0757-0346	1	RESISTOR 10 ±1% .125W TF TC=0±100	05524	
A12R51	2100-3211	1	RESISTOR-TRMR 1K 10% TKF TOP-ADJ 1-TRN	03744	
A12R52	0757-0438	1	RESISTOR 5.11K ±1% .125W TF TC=0±100	05524	
A12R53	0698-3441	1	RESISTOR 215 ±1% .125W TF TC=0±100	05524	
A12R54	0757-0280	1	RESISTOR 1K ±1% .125W TF TC=0±100	05524	
A12R55	0698-6619	1	RESISTOR 15K ±0.1% .125W TF TC=0±25	05524	
A12R56	0698-3444	1	RESISTOR 316 ±1% .125W TF TC=0±100	05524	
A12R57	0757-0346	1	RESISTOR 10 ±1% .125W TF TC=0±100	05524	
A12R58	2100-3211	1	RESISTOR-TRMR 1K 10% TKF TOP-ADJ 1-TRN	03744	
A12R59	0757-0438	1	RESISTOR 5.11K ±1% .125W TF TC=0±100	05524	
A12R60	0698-3441	1	RESISTOR 215 ±1% .125W TF TC=0±100	05524	
A12R61	0757-0280	1	RESISTOR 1K ±1% .125W TF TC=0±100	05524	
A12R62	0698-6619	1	RESISTOR 15K ±0.1% .125W TF TC=0±25	05524	
A12R63	0698-3444	1	RESISTOR 316 ±1% .125W TF TC=0±100	05524	
A12R64	0757-0346	1	RESISTOR 10 ±1% .125W TF TC=0±100	05524	
A12R65	2100-3211	1	RESISTOR-TRMR 1K 10% TKF TOP-ADJ 1-TRN	03744	
A12R66	0698-3154	1	RESISTOR 4.22K ±1% .125W TF TC=0±100	05524	
A12R67	0698-3441	1	RESISTOR 215 ±1% .125W TF TC=0±100	05524	
A12R68	0757-0280	1	RESISTOR 1K ±1% .125W TF TC=0±100	05524	
A12R69	0698-8191	1	RESISTOR 12.5K ±0.1% .125W TF TC=0±25	05524	
A12R70	0698-8827	1	RESISTOR 1M ±1% .125W TF TC=0±100	05524	
A12R71	0757-0442	1	RESISTOR 10K ±1% .125W TF TC=0±100	05524	
A12R72	0698-6362	1	RESISTOR 1K ±0.1% .125W TF TC=0±25	05524	
A12R73	0757-0158	1	RESISTOR 619 ±1% .5W TF TC=0±100	05524	
A12R74	0757-0416	1	RESISTOR 511 ±1% .125W TF TC=0±100	05524	
A12R75	0757-0419	1	RESISTOR 681 ±1% .125W TF TC=0±100	05524	
A12R76	0757-0346	1	RESISTOR 10 ±1% .125W TF TC=0±100	05524	
A12R77	0698-3406	1	RESISTOR 1.33K ±1% .5W TF TC=0±100	05524	
A12R78	0698-3647	1	RESISTOR 15K ±5% 2W MO TC=0±200	02499	GS-3
A12TP1 - TP11	1460-2201	11	SPRING RADIAL TEST POINT		
A12U1	1826-0677	1	IC V RGLTR-ADJ-POS 1.2/32V TO-3 PKG	03406	LM338K
A12U2	1826-0773	1	IC OP AMP GP 8 PIN TO-99	03406	LM10CH
A12U3	1826-1081	1	IC OP AMP PRON 8 PIN DIP-P	03406	LF411ACN
A12U4	1826-1437	1	IC V RGLTR-V-REF-FXD 9.995/10.005V	10858	LT1021CCN8-10
A12U5-U6	1826-0065	1	IC COMPARATOR PRON 8 PIN DIP-P	03406	LM311N
A12U7	1826-0677	1	IC V RGLTR-ADJ-POS 1.2/32V TO-3 PKG	03406	LM338K
A12U8	1826-0423	1	IC V RGLTR-ADJ-POS 3-TO-3 PKG	03406	LM317K
A12U9	1826-0523	1	IC V RGLTR-ADJ-NEG 3-TO-3 PKG	03406	LM337K
A12U10	1826-0527	1	IC V RGLTR-ADJ-NEG 1.2/37V 3-TO-220 PKG	03406	LM337T

*Replaceable Parts List for A12 Assembly (4 of 4)*

Reference Designation	HP Part Number	Qty	Description	Mfr Code	Mfr Part Number
A12VR1	1902-3036	1	DIODE-ZNR 3.16V 5% DO-7 PD=.4W TC=-.064C	02037	SZ30016-3
A12VR2-VR3	1902-0244	1	DIODE-ZNR 30V 5% PD=1W IR=5UA	02037	1N4751ARL
A12VR4	1902-0202	1	DIODE-ZNR 15V 5% PD=1W IR=5UA	02037	1N4744ARL
A12VR5-VR6	1902-3224	1	DIODE-ZNR 17.8V 5% DO-35 PD=.4W	02037	SZ30016-2
A12VR7	1902-3036	1	DIODE-ZNR 3.16V 5% DO-7 PD=.4W TC=-.064C	02037	SZ30016-3
A12VR8	1902-0556	1	DIODE-ZNR 20V 5% PD=1W IR=5UA	02037	1N4747ARL
A12VR9	1902-0244	1	DIODE-ZNR 30V 5% PD=1W IR=5UA	02037	1N4751ARL
A12VR10	1902-3005	1	DIODE-ZNR 2.43V 5% DO-7 PD=.4W TC=-.076C	02037	SZ30016-5
A12VR11	1902-3110	1	DIODE-ZNR 5.9V 2% DO-35 PD=.4W TC=+.017C	02037	SZ30016-1
A12VR12	1902-3005	1	DIODE-ZNR 2.43V 5% DO-7 PD=.4W TC=-.076C	02037	SZ30016-5
A12VR13	1902-3110	1	DIODE-ZNR 5.9V 2% DO-35 PD=.4W TC=+.017C	02037	SZ30016-1
A12VR14	1902-0025	1	DIODE-ZNR 10V 5% DO-35 PD=.4W TC=+.06%	02037	SZ30016-1
A12VR15	1902-3220	1	DIODE-ZNR 16.9V 2% DO-35 PD=.4W	02037	SZ30016-2
A12VR16	1902-0025	1	DIODE-ZNR 10V 5% DO-35 PD=.4W TC=+.06%	02037	SZ30016-1
A12VR17	1902-3220	1	DIODE-ZNR 16.9V 2% DO-35 PD=.4W	02037	SZ30016-2
A12VR18	1902-0064	1	DIODE-ZNR 7.5V 5% DO-35 PD=.4W TC=+.05%	02037	SZ30016-1
A12VR19-VR21	1902-0686	1	DIODE-ZNR 6.2V 2% DO-7 PD=.4W TC=+.002%	02037	1N825
A12W1	1460-2201	1	SPRING RADIAL TEST POINT		

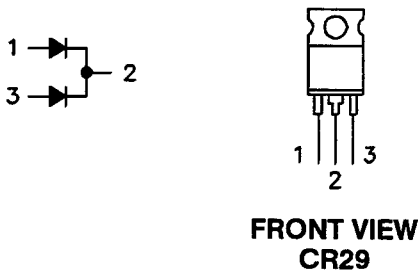
## NOTES

1. Refer to Figure 8-1 for detailed schematic diagram symbology notes.
2. Resistance values shown are in ohms, capacitance in microfarads, and inductance in microhenries unless otherwise noted.
3. Line module PC board diagram as seen from assembly connection side:

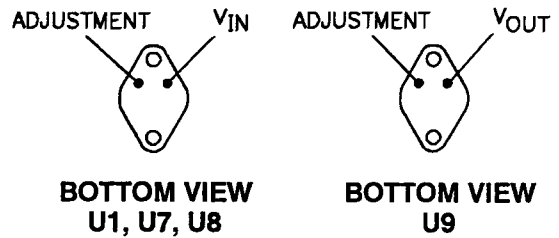


Refer to section 2, "Installation" for line voltage selection procedure.

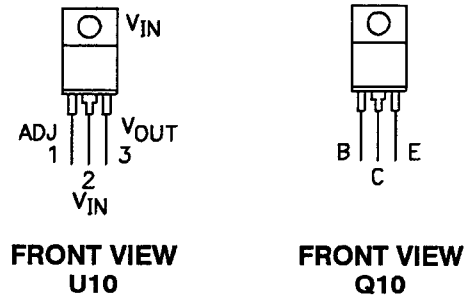
4. CR29 is attached to side of heat sink.



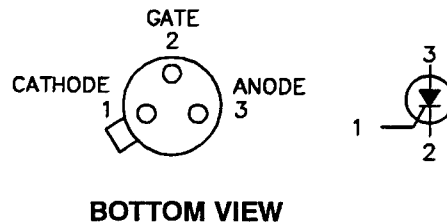
5. U1, U7, U8, and U9 are mounted to a common heat sink. The case of each device is one of three active terminals. The case electrically connects to the A12 PC board via the mounting screws. The other two pins connect through holes in the heat sink to pin sockets. These pins may be probed without removing the device at: (1) fuse at input; (2) test point at output; or (3) PC pads (not test points) labeled "7R" for U7, "8R" for U8, etc.



6. U10 and Q10 are attached to the side of heat sink.



7. Q2, Q6, Q7, Q8, Q9, Q11



*Figure 8-35. A12 Power Supply and Component Illustrations (1 of 2)*



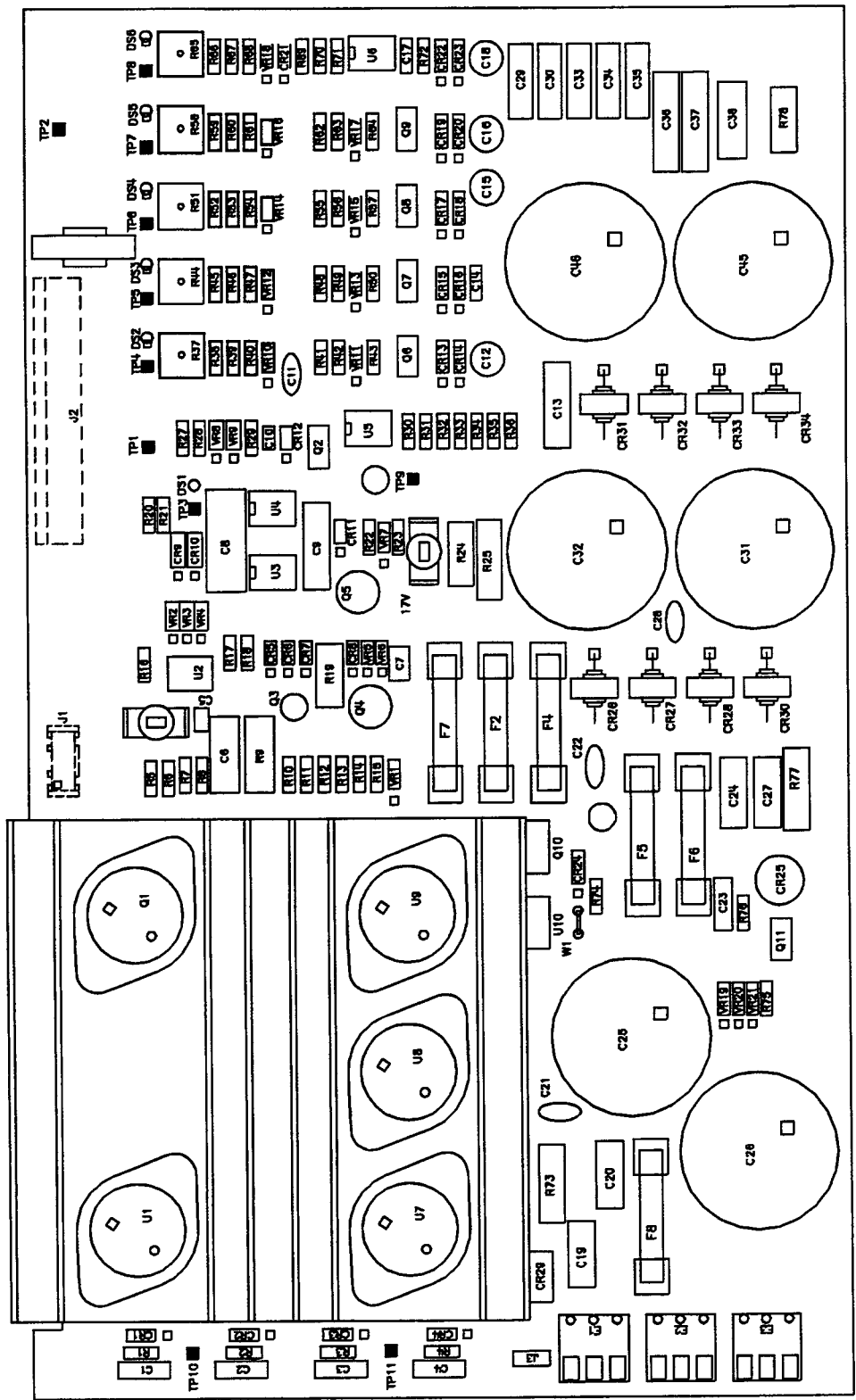
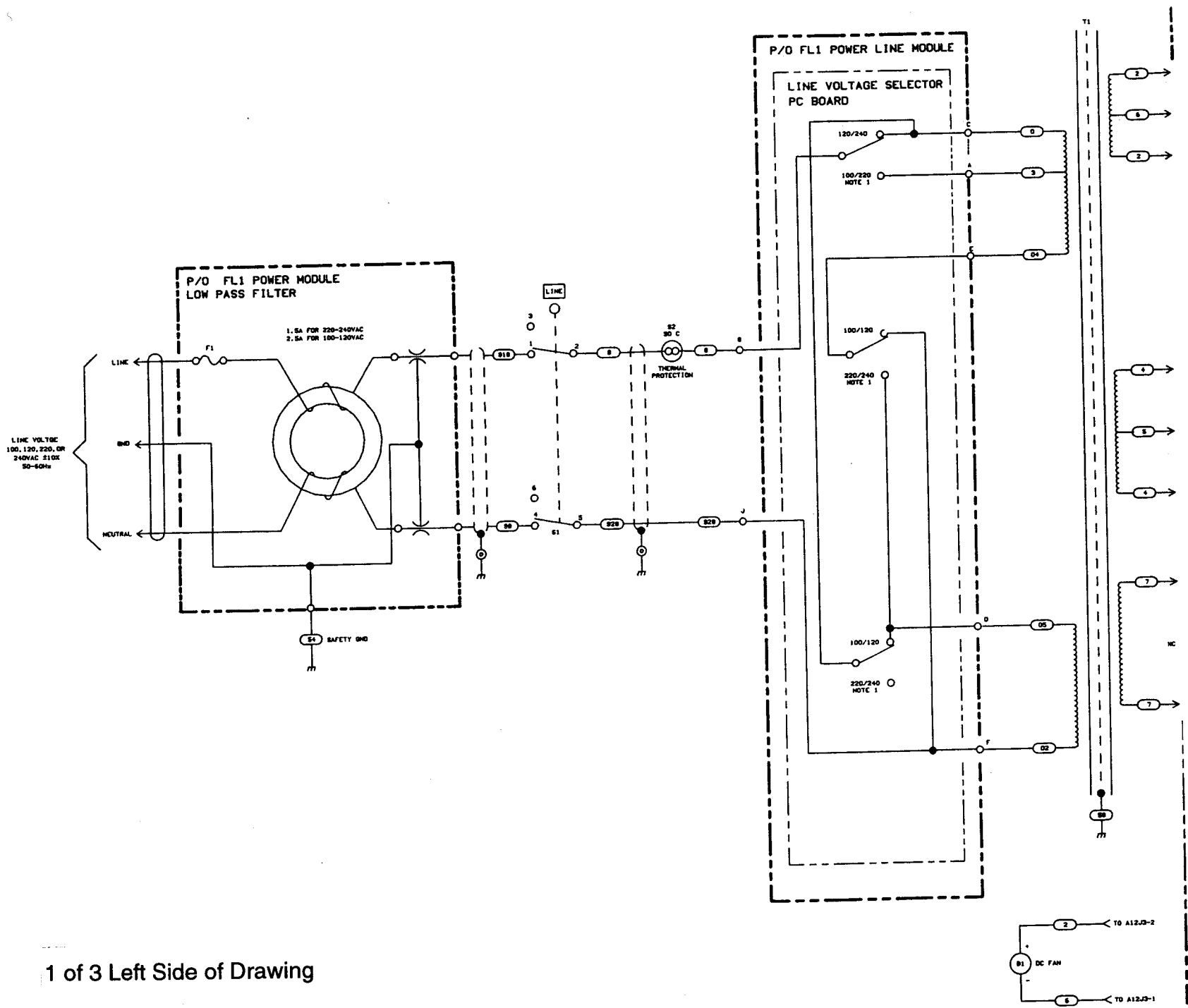
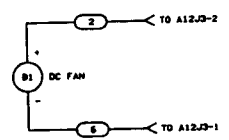
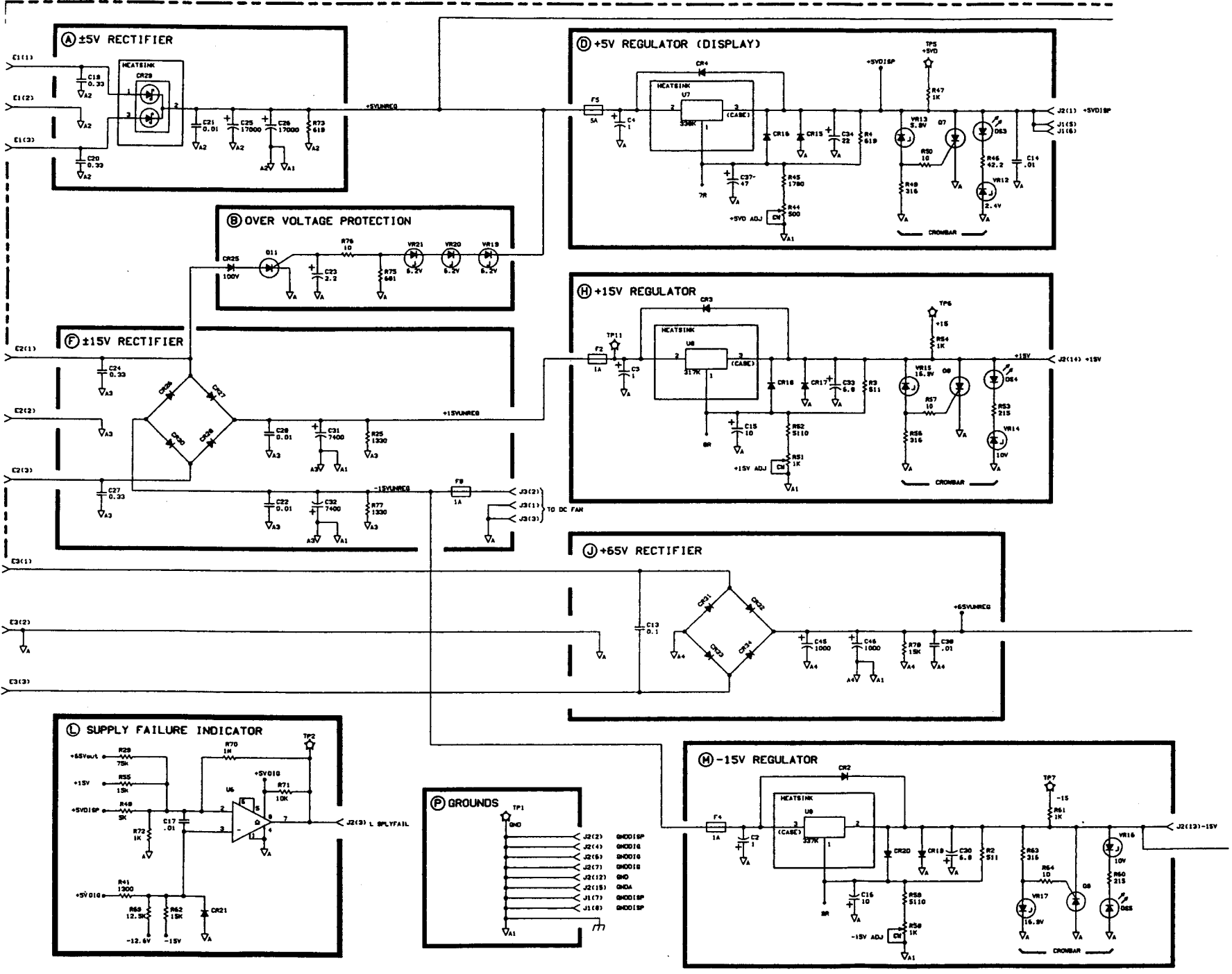


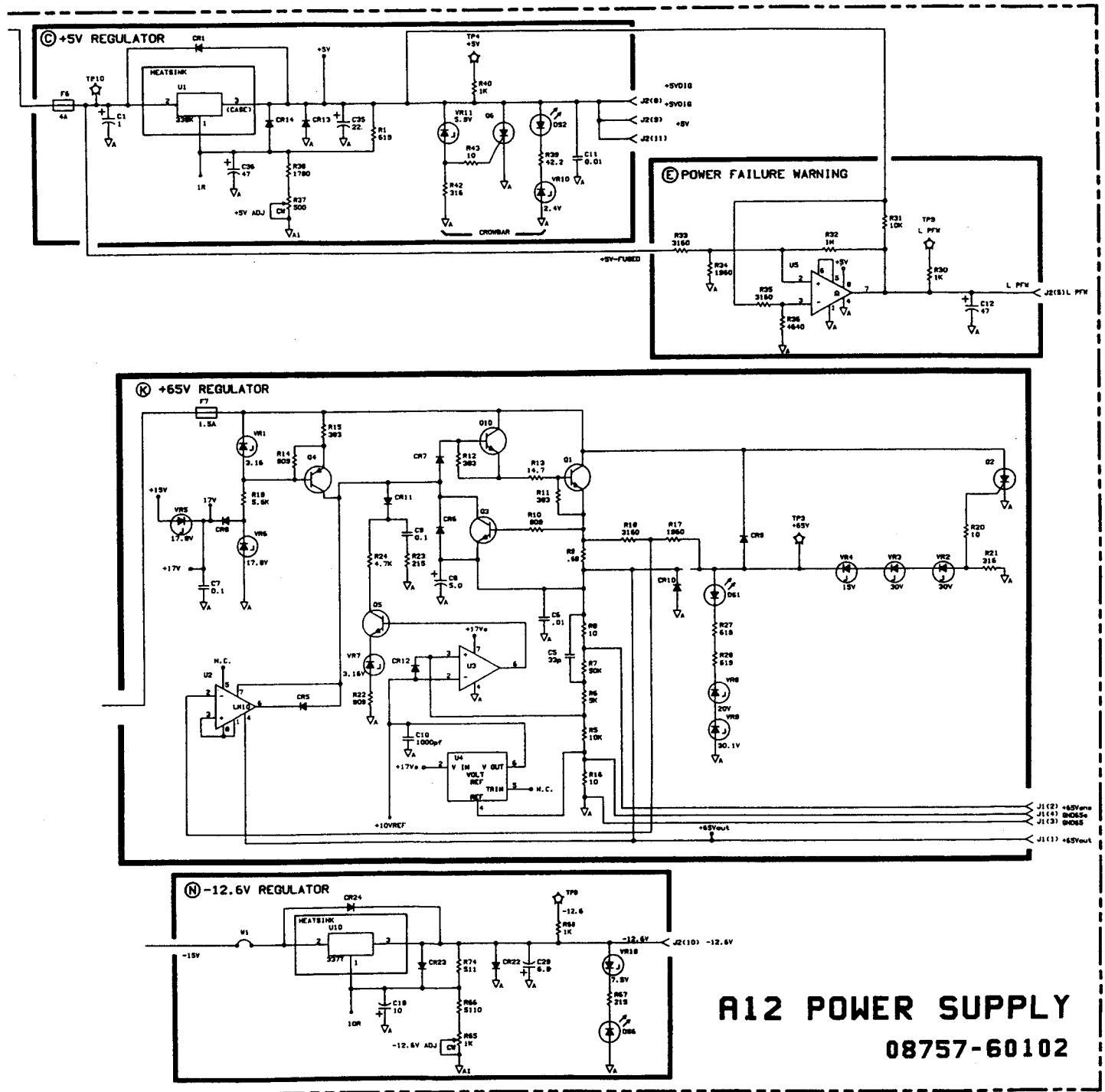
Figure 8-35. A12 Power Supply and Component Illustrations (2 of 2)



1 of 3 Left Side of Drawing







3 of 3 Right Side of Drawing

**A12 POWER SUPPLY**  
**08757-60102**

## A11 Motherboard and A13 Rear Panel

*Table 8–27. HP 8757D A11 Motherboard Wiring List (1 of 6)*

Mnemonic	Source	Description	A1/A2 A11J1	A3 XA3J1	A4 XA4J1	A4 XA4J2	A5 XA5J1	A6 XA6J1	A7 "A" XA7J1	A8 "B" XA8J1	A9 "C" XA9J1
AAI SHLD	A13J8	Auxiliary ADC Input Shield			2						
L AATN	A6P1–39	HP–IB "Attention"						39			
L ADV	A6P1–37	HP–IB "Data Available"						37			
L ADIO 1	A6P1–24	HP–IB Data Bit 1 (LSB)						24			
L ADIO 2	A6P1–25	HP–IB Data Bit 2						25			
L ADIO 3	A6P1–26	HP–IB Data Bit 3						26			
L ADIO 4	A6P1–27	HP–IB Data Bit 4						27			
L ADIO 5	A6P1–28	HP–IB Data Bit 5						28			
L ADIO 6	A6P1–29	HP–IB Data Bit 6						29			
L ADIO 7	A6P1–30	HP–IB Data Bit 7						30			
L ADIO 8	A6P1–31	HP–IB Data Bit 8						31			
ADO SHLD	A11J8–59	Auxiliary DAC Output Shield				37					
L AEOI	A6J1–38	HP–IB "End or Identify"						38			
L AIFC	A6J1–34	HP–IB "Interface Clear"						34			
A IN SHLD	A11J2–1	Detector A Input Shield							2,5, 20,23		
L ANDAC	A6J1–35	HP–IB "Not Data Accepted"						35			
L ANRFD	A6H1–36	HP–IB "Not Ready for Data"						36			
L AREN	A6J1–33	HP–IB "Remote Enable"						33			
L ASRQ	A6J1–40	HP–IB "Service Request"						40			
ATTN BIAS	A4J1–4	Calibrator Control Option 002			4		4				
ATTEN EN	A4J1–23	Calibrator Control (Option 002)			23		23				
ATTN 1	A4J1–6	Calibrator Control (Option 002)			6		24				
ATTN 20	A4J1–5	Calibrator Control (Option 002)			5		5				
AUX ADC IN	A13J8	Auxiliary ADC Input			1						
AUX DAC OUT	A4J2–38	Auxiliary DAC Output				38					
L BATN	A6J1–18	8757 System Intfc "Attention"						18			
L BDAV	A6J1–16	8757 System Intfc "Data Available"						16			
L BDIO 1	A6J1–3	8757 System Intfc Data Bit 1 (LSB)						3			
L BDIO 2	A6J1–4	8757 System Intfc Data Bit 2						4			
L BDIO 3	A6J1–5	8757 System Intfc Data Bit 3						5			
L BDIO 4	A6J1–6	8757 System Intfc Data Bit 4						6			
L BDIO 5	A6J1–7	8757 System Intfc Data Bit 5						7			
L BDIO 6	A6J1–8	8757 System Intfc Data Bit 6						8			
L BDIO 7	A6J1–9	8757 System Intfc Data Bit 7						9			
L BDIO 8	A6J1–19	8757 System Intfc Data Bit 8						10			
L BEOI	A6J1–17	8757 System Intfc "End or Identify"						17			
L BIFC	A6J1–13	8757 System Intfc "Interface Clear"						13			
B IN SHLD	A11J3–1	Detector B Input Shield								2,5, 20,23	
L BNDAC	A6J1–14	8757 System Intfc "Not Data Ready"						14			
L BNRFD	A6J1–15	8757 System Intfc "Not Ready for Data"						15			
L BREN	A6J1–12	8757 System Intfc "Remote Enable"						12			
L BSRQ	A6J1–19	8757 System Intfc "Service Request"						19			
CAL MOD EN	A3J1–32	Not Currently Used		32			31				
CAL ON	A4J1–7	Calibrator Control (Option 002)			7		25				
CAL OSC EN	A3J1–76	Not Currently Used		76			14				

Table 8-27. HP 8757D A11 Motherboard Wiring List (2 of 6)

A10 "R" XA10J1	"A" Input A11J2	"B" Input A11J3	"C" Input A11J4	"R" Input A11J5	A12 A11J6	A13 A11J8	A14 A11J7	Description	Source	Mnemonic
						57		Auxiliary ADC Input Shield	A13J8	AAI SHLD
						43		HP-IB "Attention"	A6P1-39	L AATN
						41		HP-IB "Data Available"	A6P1-37	L ADV
						24		HP-IB Data Bit 1 (LSB)	A6P1-24	L ADIO 1
						25		HP-IB Data Bit 2	A6P1-25	L ADIO 2
						26		HP-IB Data Bit 3	A6P1-26	L ADIO 3
						27		HP-IB Data Bit 4	A6P1-27	L ADIO 4
						28		HP-IB Data Bit 5	A6P1-28	L ADIO 5
						29		HP-IB Data Bit 6	A6P1-29	L ADIO 6
						30		HP-IB Data Bit 7	A6P1-30	L ADIO 7
						31		HP-IB Data Bit 8	A6P1-31	L ADIO 8
						59		Auxiliary DAC Output Shield	A11J8-5	ADO SHLD
						33		HP-IB "End or Identify"	A6J1-38	L AEOI
						35		HP-IB "Interface Clear"	A6J1-34	L AIFC
	1							Detector A Input Shield	A11J2-1	A IN SHLD
						37		HP-IB "Not Data Accepted"	A6J1-35	L ANDAC
						39		HP-IB "Not Ready for Data"	A6H1-36	L ANRFD
						32		HP-IB "Remote Enable"	A6J1-33	L AREN
						45		HP-IB "Service Request"	A6J1-40	L ASRQ
								Calibrator Control (Option 002)	A4J1-4	ATTN BIAS
								Calibrator Control (Option 002)	A4J1-23	ATTEN EN
								Calibrator Control (Option 002)	A4J1-6	ATTN 1
								Calibrator Control (Option 002)	A4J1-5	ATTN 20
						58		Auxiliary ADC Input	A13J8	AUX ADC IN
						60		Auxiliary DAC Output	A4J2-38	AUX DAC OUT
						20		8757 System Intfc "Attention"	A6J1-18	L BATN
						18		8757 System Intfc "Data Available"	A6J1-16	L BDAV
						1		8757 System Intfc Data Bit 1 (LSB)	A6J1-3	L BDIO 1
						2		8757 System Intfc Data Bit 2	A6J1-4	L BDIO 2
						3		8757 System Intfc Data Bit 3	A6J1-5	L BDIO 3
						4		8757 System Intfc Data Bit 4	A6J1-6	L BDIO 4
						5		8757 System Intfc Data Bit 5	A6J1-7	L BDIO 5
						6		8757 System Intfc Data Bit 6	A6J1-8	L BDIO 6
						7		8757 System Intfc Data Bit 7	A6J1-9	L BDIO 7
						8		8757 System Intfc Data Bit 8	A6J1-19	L BDIO 8
						10		8757 System Intfc "End or Identify"	A6J1-17	L BEOI
						12		8757 System Intfc "Interface Clear"	A6J1-13	L BIFC
								Detector B Input Shield	A11J3-1	B IN SHLD
						14		8757 System Intfc "Not Data Ready"	A6J1-14	L BNDAC
						16		8757 System Intfc "Not Ready for Data"	A6J1-15	L BNRFD
						9		8757 System Intfc "Remote Enable"	A6J1-12	L BREN
						22		8757 System Intfc "Service Request"	A6J1-19	L BSRQ
								Not Currently Used	A3J1-32	CAL MOD EN
								Calibrator Control (Option 002)	A4J1-7	CAL ON
								Not Currently Used	A3J1-76	CAL OSC EN

Table 8–27. HP 8757D A11 Motherboard Wiring List (3 of 6)

Mnemonic	Source	Description	A1/A2 A11J1	A3 XA3J1	A4 XA4J1	A4 XA4J2	A5 XA5J1	A6 XA6J1	A7 "A" XA7J1	A8 "B" XA8J1	A9 "C" XA9J1
CAL PWR	A5J1–22	Cal Out Det. (Option 002)			3		22				
C IN SHLD	A11J4–1	Detector C Input Shield (Option 001)									2,5, 20,23
CNTL A	ARJ1–21	Detector A Input Control	31		21						
CNTL B	ARJ1–20	Detector B Input Control	34		20						
CNTL C	A4J1–24	Detector C Input Control (Option 001)	32		24						
CNTL R	ARJ1–19	Detector R Input Control	33		19						
CNTRL1	A3J1–79	Rear Panel Control Number 1		79							
CNTRL1 GND	A8J1–52	Rear Panel Control Number 1 Ground									
CNTRL2	A3J1–40	Rear Panel Control Number 2		40							
CNTRL2 GND	A8J1–54	Rear Panel Control Number 2 Ground									
L DISP	A3J1–38	L=Display Data Strobe		38							
L DISP INT	A14J1–31	L=Display Interrupt									
L DR INT	A4J2–55	L=Data Ready Interrupt		55		55					
IA1	A3J1–25	Instrument Bus Address Bit 1 (LSB)	19	25		25		65			
IA2	A3J1–24	Instrument bus Address Bit 2	20	24		24		64			
IA3	A3J1–23	Instrument Bus Address Bit 3	17	23		23		63			
IA4	A3J1–22	Instrument Bus Address Bit 4	18	22		22		62			
IA5	A3J1–21	Instrument Bus Address Bit 5	15	21		21		61			
IA6	A3J1–20	Instrument Bus Address Bit 6	16	20		60		60			
IA7	A3J1–60	Instrument Bus Address Bit 7	13	60		59,19		59			
IA8	A3J1–61	Instrument Bus Address Bit 8 (MSB)	14	61		61		20			
ID0	A3J1–18	Instrument Bus Data Bit 0 (LSB)	6	18		18		58			
ID1	A3J1–17	Instrument Bus Data Bit 1	5	17		17		57			
ID2	A3J1–16	Instrument Bus Data Bit 2	8	16		16		56			
ID3	A3J1–15	Instrument Bus Data Bit 3	7	15		15		55			
ID4	A3J1–14	Instrument Bus Data Bit 4	10	14		14		54			
ID5	A3J1–13	Instrument Bus Data Bit 5	9	13		13		53			
ID6	A3J1–12	Instrument Bus Data Bit 6	12	12		12		52			
ID7	A3J1–11	Instrument Bus Data Bit 7	11	11		11		51			
ID8	A3J1–10	Instrument Bus Data Bit 8		10		10		50			
ID9	A3J1–9	Instrument Bus Data Bit 9		9		9		49			
ID10	A3J1–8	Instrument Bus Data Bit 10		8		8		48			
ID11	A3J1–7	Instrument Bus Data Bit 11		7		7		47			
ID12	A3J1–6	Instrument Bus Data 12		6		6		46			
ID13	A3J1–5	Instrument Bus Data Bit 13		5		5		45			
ID14	A3J1–4	Instrument Bus Data Bit 14		4		4		44			
ID14	ASJ1–3	Instrument Bus Data Bit 15		3		3		43			
INA	A11J2–2	Channel A Input							3,21		
INARTN	A11J2–3	Channel A Input Return							4,22		
INB	A11J3–2	Channel B Input								21,3	
INBRTN	A11J3–3	Channel B Input Return								4,22	
INC	A11J4–2	Channel C Input (Option 001)									21,3
INCRTN	A11J4–3	Channel C Input Return (Option 001)									4,22
INR	A11J52–2	Channel R Input									

Table 8-27. HP 8757D A11 Motherboard Wiring List (4 of 6)

A10 "R" XA10J1	"R" Input A11J2	"B" Input A11J3	"C" Input A11J4	"R" Input A11J5	A12 A11J6	A13 A11J8	A14 A11J7	Description	Source	Mnemonic
			1					Cal Out Det. (Option 002) Detector C Input Shield (Option 001) Detector A Input Control Detector B Input Control Detector C Input Control (Option 001)	A4J1-3 A11J4-1 ARJ1-21 ARJ1-20 A4J1-24	CAL PWR C IN SHLD CNTL A CNTL B CNTL C
						51 52 53 54		Detector R Input Control Rear Panel Control Number 1 Rear Panel Control Number 1 Ground Rear Panel Control Number 2 Rear Panel Control Number 2 Ground	ARJ1-19 A3J1-79 A8J1-52 A3J1-40 A8J1-54	CNTL R CNTRL1 CNTRL1 GND CNTRL2 CNTRL2 GND
							30 31	L=Display Data Strobe L=Display Interrupt L=Data Ready Interrupt	A3J1-38 A14J1-31 A4J2-55	L DISP L DISP INT L DR INT
							26 23 24	Instrument Bus Address Bit 1 (LSB) Instrument bus Address Bit 2 Instrument Bus Address Bit 3 Instrument Bus Address Bit 4 Instrument Bus Address Bit 5	A3J1-25 A3J1-24 A3J1-23 A3J1-22 A3J1-21	IA1 IA2 IA3 IA4 IA5
							19 20	Instrument Bus Address Bit 6 Instrument Bus Address Bit 7 Instrument Bus Address Bit 8 (MSB) Instrument Bus Data Bit 0 (LSB) Instrument Bus Data Bit 1	A3J1-20 A3J1-60 A3J1-61 A3J1-18 A3J1-17	IA6 IA7 IA8 ID0 ID1
							17 18 15 16 13 14	Instrument Bus Data Bit 2 Instrument Bus Data Bit 3 Instrument Bus Data Bit 4 Instrument Bus Data Bit 5 Instrument Bus Data Bit 6 Instrument Bus Data Bit 7	A3J1-16 A3J1-15 A3J1-14 A3J1-13 A3J1-12 A3J1-11	ID2 ID3 ID4 ID5 ID6 ID7
							9 10 7 8 5	Instrument Bus Data Bit 8 Instrument Bus Data Bit 9 Instrument Bus Data Bit 10 Instrument Bus Data Bit 11 Instrument Bus Data 12	A3J1-10 A3J1-9 A3J1-8 A3J1-7 A3J1-6	ID8 ID9 ID10 ID11 ID12
	2 3						6 3 4	Instrument Bus Data Bit 13 Instrument Bus Data Bit 14 Instrument Bus Data Bit 15 Channel A Input Channel A Input Return	A3J1-5 A3J1-4 ASJ1-3 A11J2-2 A11J2-3	ID13 ID14 ID14 INA INARTN
		2 3	2 3					Channel B Input Channel B Input Return Channel C Input (Option 001) Channel C Input Return (Option 001) Channel R Input	A11J3-2 A11J3-3 A11J4-2 A11J4-3 A11J52-2	INB INBRTN INC INCRTN INR
21,3				2						



Table 8-27. HP 8757D All Motherboard Wiring List (5 of 6)

Mnemonic	Source	Description	A1/A2 A11J1	A3 XA3J1	A4 XA4J1	A4 XA4J2	A5 XA5J1	A6 XA6J 1	A7 "R" XA7J1	A8 "B" XA8J1	A9 "C" XA9J1
INRRTN L IOS L 1PRESET LOG A LOG A COM	A11J5-3 A3J1-27 A11J2-25 A7J1-35 A7J1-34	Channel R Input Return L=I/O Strobe L=Preset (Front Panel Button) Channel A Logger Output Channel A Logger Common	21 25	27 74		27		67	35 34		
LOG B LOG B COM LOG C LOG C COM LOG R	A8J1-35 A8J1-34 A9J1-35 A9J1-34 A10J1-35	Channel B Logger Output Channel B Logger Common Channel C Logger Output (Opt. 001) Channel C Logger Common (Opt. 001) Channel R Logger Output			10 28 11 29 12					35 34	35 34
LOG R COM L LOG TEMP L LOG ZERO LPFW PZAB	A10J1-34 A4J2-34 A4J2-35 A11J6-5 A13J3	Channel R Logger Common Logger Multiplexer Control 1 Logger Multiplexer Control 2 Low Power Failure Warning Positive Z-Axis Blanking		43	30	34 35 40			14 15	14 15	14 15
R IN SHLD L RESET SPARE SPARE GND SPLY FAIL L SRQA	A10J1-22 A3J1-31   A12J1-3 A6J1-72	Detector R Input Shield L=Reset (CPU Buffered) Not Currently Used Not Currently Used Supply Failed L=Service Request A (HP Intfc Bus)	23	31  46 70		31		71 79 80 72			
L SRQB L SRQ FP STOP SWEEP L STTS INT SWEEP IN	A6J1-73 A11J1-27 A4J2-78 A4J2-62 A13J5	L=Service Request B (8757 System Bus) L=Service Request Front Panel Stop Sweep L=Status Interrupt Sweep In Ramp	27	19  56		78 62 80					
SWEEP RTN VBATT L WRITE L XACK L 27K MOD DR 5MHZ	A13J5 A3J1-44 A3J1-29 A11J7-29 A3J1-75 A3J1-35	Sweep In Return Not Currently Used L=Write (H=Read) L=Transfer Acknowledge L=27 kHz Modulator Drive On 5 MHz Clock (HP-IB)		29 73 75 35		79 29		69 75			
+15V +5V +5V DIG GND GND A	A11J6-14 A11J68-1 1 A11J6-8 A11J6-12 A11J6-15	+15 Vdc Power Supply +5 Vdc (Analog) Power Supply +5 Vdc Digital Power Supply Ground (General Analog) Ground Analog (Low Noise)	35,36  1,2	  41,1	15,33 18,36  35,17 14,32, 8,26	  41,1	33,15 18,36  17,35	1,41	30,12 28,10	30,12 28,10	30,12 28,10
GND DIG GND DIG SH  GND DISP GND PLANE  -12.6V -15V	A11J6-6   A11J7-1 A11J6-4  A11J6-10 A11J6-13	Ground Digital Ground Digital Shield  Ground Display Ground Plane (Analog Shield)  -12.6 Vdc Power Supply -15 Vdc Power Supply	3,4 22,24, 26,28, 30 37,38 39,40	42,2 26,28 30,34		42,2 30		2,42 70 36 9,10, 11,12 27,28 29,30	1,6, 9,13, 18,19, 24,27, 31,36	6,9, 13,18, 19,24, 27,31, 36,1	19,24, 27,31, 36,6 9,13 18,1
						16,34	16,34	25,7	7,25	25,7	

Table 8-27. HP 8757D A11 Motherboard Wiring List (6 of 6)

A10 "R" XA10J1	"A" Input A11J2	"B" Input A11J3	"C" Input A11J4	"R" Input A11J5	A12 A11J6	A13 A11J8	A14 A11J7	Description	Source	Mnemonic
4,22				3				Channel R Input Return L=I/O Strobe L=Preset (Front Panel Button) Channel A Logger Output Channel A Logger Common	A11J5-3 A3J1-27 A11J2-25 A7J1-35 A7J1-34	INRRTN L IOS L 1PRESET LOG A LOG A COM
35								Channel B Logger Output Channel B Logger Common Channel C Logger Output (Opt. 001) Channel C Logger Common (Opt. 001) Channel R Logger Output	A8J1-35 A8J1-34 A9J1-35 A9J1-34 A10J1-35	LOG B LOG B COM LOG C LOG C COM LOG R
34 14 15					25	48		Channel R Logger Common Logger Multiplexer Control 1 Logger Multiplexer Control 2 Low Power Failure Warning Positive Z-Axis Blanking	A10J1-34 A4J2-34 A4J2-35 A11J6-5 A13J3	LOG R COM L LOG TEMP L LOG ZERO LPFW PZAB
2,5, 20,23				1				Detector R Input Shield  L=Reset (CPU Buffered) Not Currently Used Not Currently Used Supply Failed L=Service Request A (HP Intfc Bus)	A10J1-22  A3J1-31  A12J1-3 A6J1-72	R IN SHLD  L RESET SPARE SPARE GND SPLY FAIL L SRQA
								L=Service Request B (8757 System Bus) L=Service Request Front Panel Stop Sweep L=Status Interrupt Sweep In Ramp	A6J1-73 A11J1-27 A4J2-78 A4J2-62 A13J5	L SRQB L SRQ FP STOP SWEEP L STTS INT SWEEP IN
						49		Sweep In Return Not Currently Used L=Write (H=Read) L=Transfer Acknowledge L=27 kHz Modulator Drive On 5 MHz Clock (HP-IB)	A13J5 A3J1-44 A3J1-29 A11J7-29 A3J1-75 A3J1-35	SWEEP RTN VBATT L WRITE L XACK L 27K MOD DR 5MHZ
30,12 28,10					14 11  8,9 12 15			+15 Vdc Power Supply +5 Vdc (Analog) Power Supply  +5 Vdc Digital Power Supply Ground (General Analog) Ground Analog (Low Noise)	A11J6-14 A11J68-1 1 A11J6-8 A11J6-12 A11J6-15	+15V +5V  +5V DIG GND GND A
					6,7	11,13, 15,17, 19,21, 23,24, 36,38, 40,42, 44,46		Ground Digital Ground Digital Shield	A11J6-6	GND DIG GND DIG SH
					2		1,2, 11,12, 21,22, 27,28, 33,34	Ground Display	A11J7-1	GND DISP
19,24,2 8,31,6, 9,18,36 ,1,13					4			Ground Plane (Analog Shield)	A11J6-4	GND PLANE
25,7					10 13			-12.6 Vdc Power Supply -15 Vdc Power Supply	A11J6-10 a11J6-13	-12.6V -15V

*Replaceable Parts List for A11 Assembly (1 of 1)*

<b>Reference Designation</b>	<b>HP Part Number</b>	<b>Qty</b>	<b>Description</b>	<b>Mfr Code</b>	<b>Mfr Part Number</b>
A11	08757-60066	1	BD AY-MOTHER	28480	08757-60066
A11J1	1252-2870	1	CONN-POST TYPE .100-PIN-SPCG 40-CONT	04726	3432-6203
A11J2 - J5	1251-6932	4	CONN-POST TYPE 2.5-PIN-SPCG 3-CONT	03418	22-11-1031
A11J6 - J8	1252-2918	3	CONN-POST TYPE .156-PIN-SPCG 15-CONT	03394	3007-015-2105
A11MP2	0590-1095	5	THREADED INSERT-NUT M3 X 0.5 1.5-MM-LG	03981	KF2-M3-ZI
A11MP3	1251-5595	6	POLARIZING KEY-POST CONN	04726	3518
A11XA&J1 - XA10J1	1251-7908	9	CONN-POST TYPE .100-PIN-SPCG 80-CONT	01380	1-534978-1

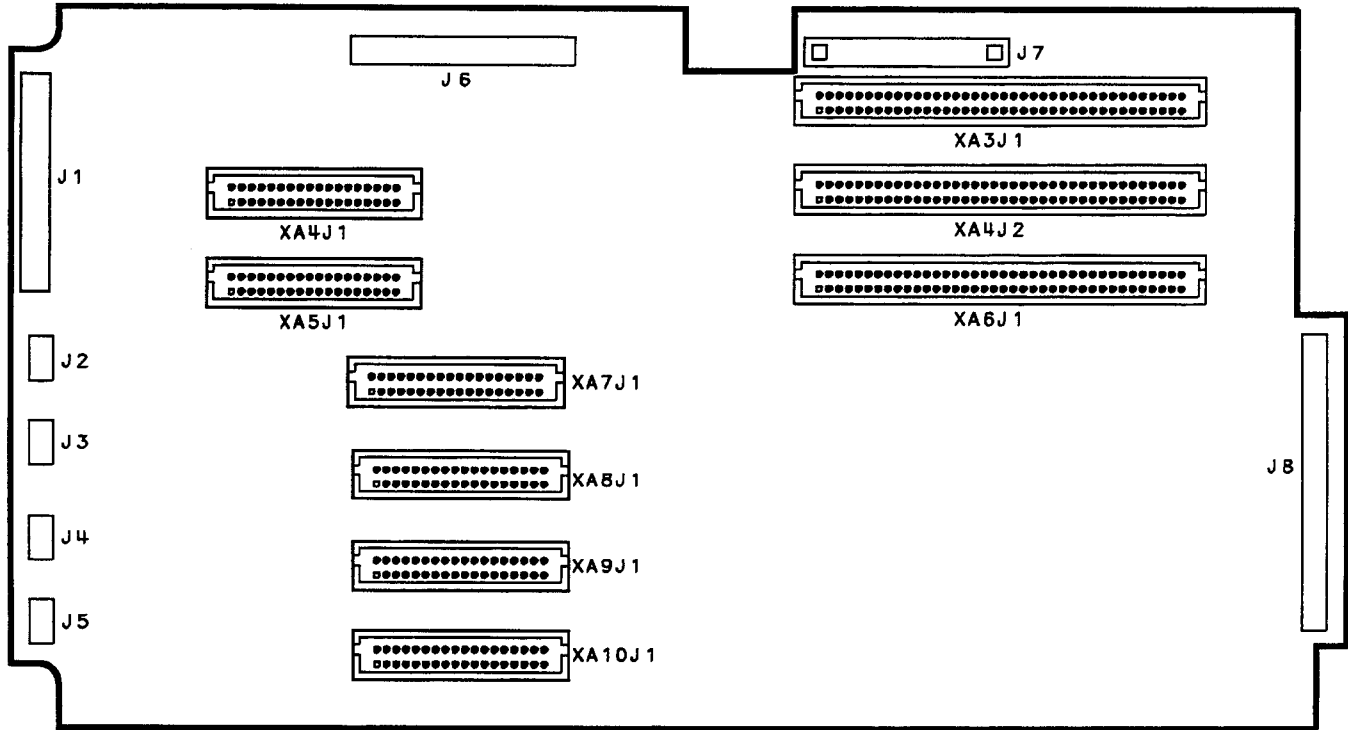


Figure 8-37. All Component Locations Diagram

*Replaceable Parts List for A13 Assembly (1 of 1)*

<b>Reference Designation</b>	<b>HP Part Number</b>	<b>Qty</b>	<b>Description</b>	<b>Mfr Code</b>	<b>Mfr Part Number</b>
A13	08757-60013	1	BD ASSY-REAR PNL	28480	08757-60013
A13C1-C3	0160-4574	1	CAP-FXD 1000pF ±10% 100 V CER X7R	02010	SA101C102KAAH
A13CR1-CR3	1902-0579	1	DIODE-ZNR 5.1V 5% PD=1W IR=10UA	02037	1N4733ARL
A13J1-J2	1251-8061	1	CONN-RECT MICRORBN 24-CKT 24-CONT	05879	57-20240-11-448
A13J3-J4	1250-1687	1	CONNECTOR-RF BNC RCPT PC-W-STDFS 50-OHM	03316	28JR175-7
A13J8	1250-1806	1	CONNECTOR-RF BNC RCPT PC-W-STDFS 50-OHM	03316	28JR175-8
A13J9-J10	1250-1687	1	CONNECTOR-RF BNC RCPT PC-W-STDFS 50-OHM	03316	28JR175-7
A13MP2	0380-1763	4	THREADED INSERT-STDF 6-32 .219-IN-LG BRS	03981	KFB3-632-7-ET
A13R1	0757-0795	1	RESISTOR 75 ±1% .5W TF TC=0±100	05524	CMF-65-2
A13W1	08757-60044	1	CABLE AY - 60C		
A13W2	08757-60029	1	CABLE AY - M01		

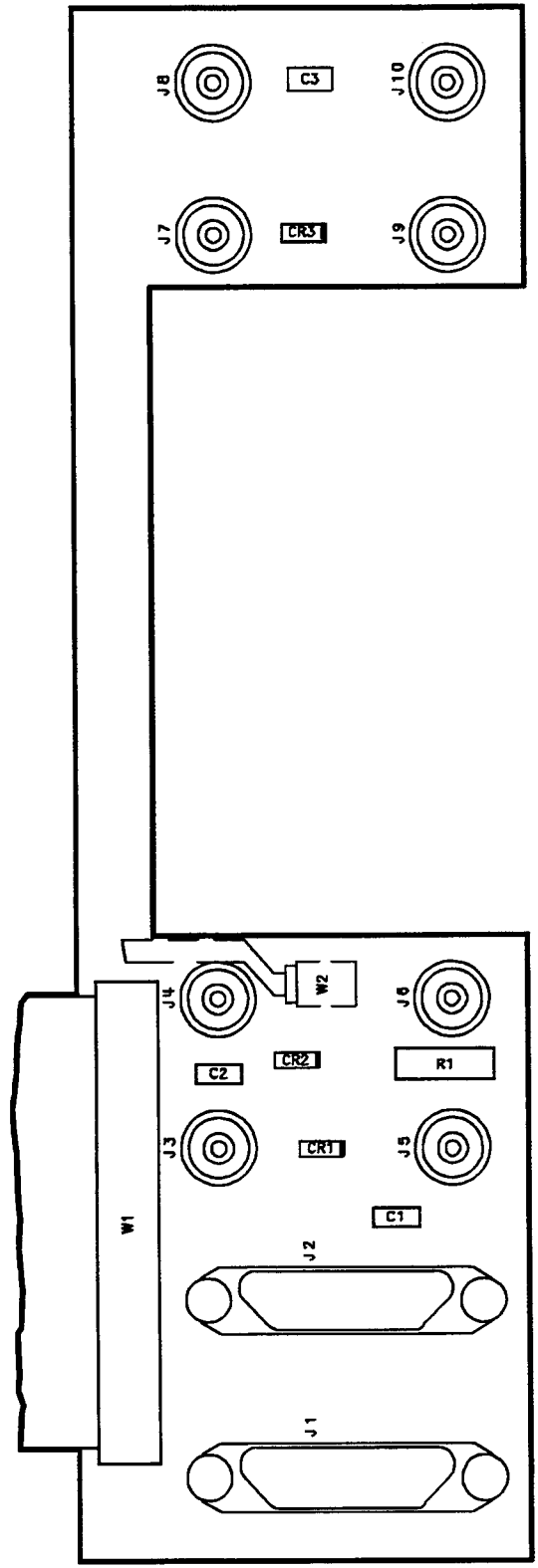
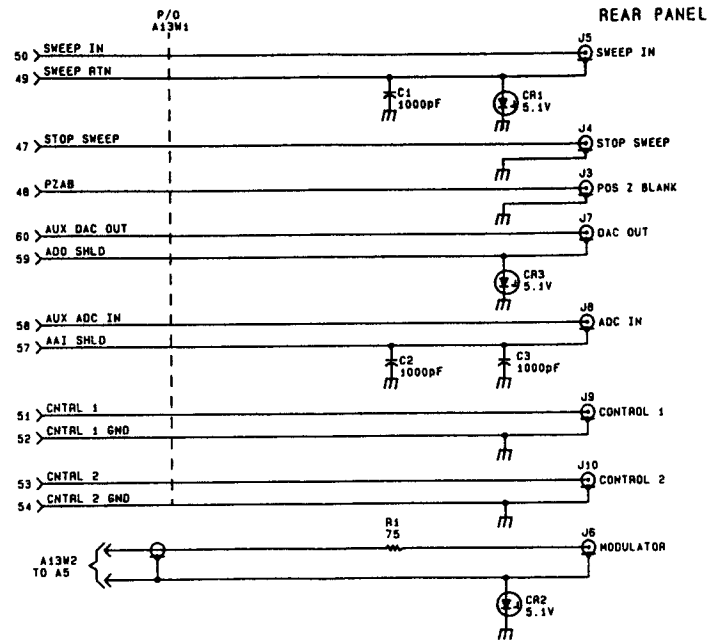
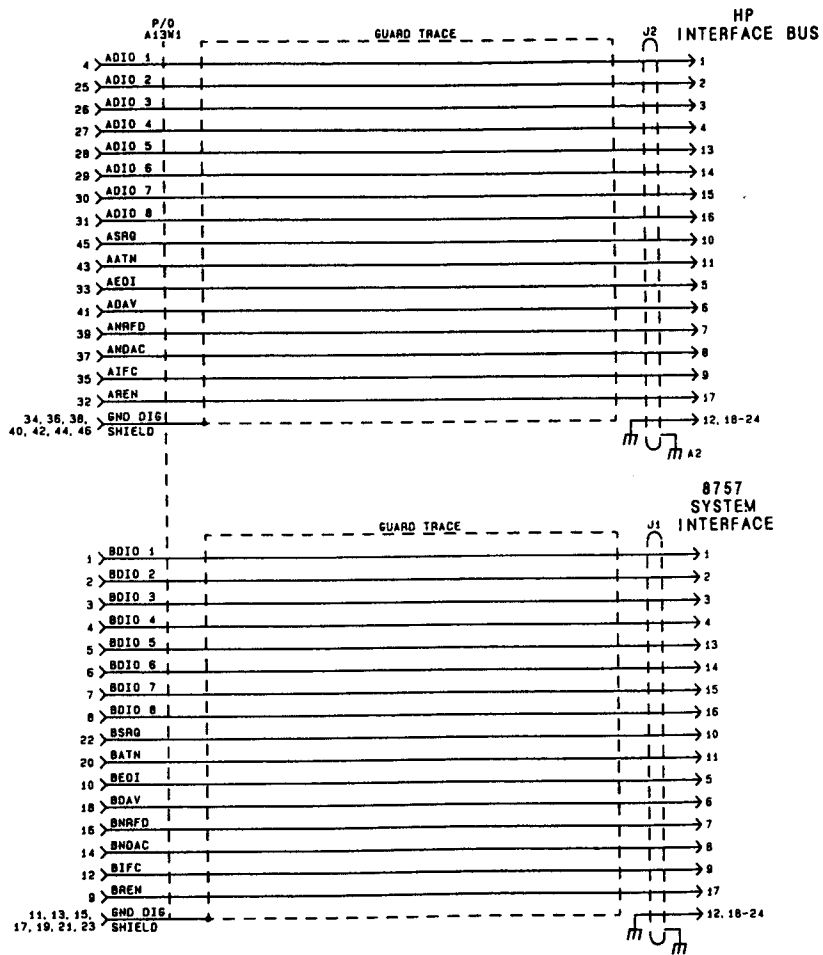


Figure 8-38. A13 Component Locations Diagram



NOTE:  
EARTH GROUND CONNECTION MADE THROUGH  
MOUNTING OF REAR PANEL

---

## A14 DISPLAY INTERFACE (GSP)

---

**NOTE** The information in this section is specific to instruments with an LCD display. Unless otherwise noted, this information does not apply to instruments with CRT displays. See the Manual Backdating chapter (blue tab) for information on the A14 assembly associated with the CRT display.

---

### CIRCUIT DESCRIPTION

The A14 display interface (GSP) graphics system processor is the main interface between the A3 central processing unit (CPU) and the A15 liquid crystal display (LCD). The A3 CPU board converts the formatted data into GSP commands and writes it to the A14 display interface board. The GSP processes the data to obtain the necessary analog and digital video signals that are used for the following purposes:

- The analog video signals are used to produce VGA compatible RGB output signals that are routed to the rear panel.
- The analog video signals are translated to 3.3 volt levels and routed to the A15 LCD.

The A14 assembly receives the +5 DSP that is used for processing and supplying power to the A16 backlight inverter (+5 V) and the A15 LCD (3.3 V).

### ADJUSTMENTS DIAGNOSTIC TESTS

There are no adjustments to be made on this board.

There are no diagnostic tests designed specifically for the revised A14 display interface that is used with the LCD.

The instrument firmware still contains the diagnostic tests designed for the previous CRT display interface. These tests are listed in Table 8-1 on page 8-6. If any of these display related tests fail, it usually indicates that the A14 display interface board needs to be replaced. For additional information, refer to the A14 section in the Manual Backdating chapter.

### TROUBLESHOOTING

---

**WARNING** +65 V lines run to J3 on the A14 display interface. Do not contact these traces or personal injury may result.

---

Component level repair of the A14 board is not supported. For this reason, a schematic and detailed parts list is not provided. If the A14 display interface board fails, it should be replaced.



## **TROUBLESHOOTING LCD DISPLAY PROBLEMS**

This procedure covers more than just the A14 display interface assembly; it also includes steps for isolating problems with the A15 and A16 assemblies.

This procedure is intended to isolate the faulty assembly if the display is dark, dim, or blank. If the display is illuminated and showing an image, but the color mix is faulty (or other image problems), refer to the A15 section, "Troubleshooting Image Problems."

1. If the display is dim, the backlight assembly is probably defective. Refer to the A15 section, "Display Front Panel Assembly" on page 8-190 for information on replacing the backlight lamp.
2. If the display remains dark after the instrument is turned on, follow the procedure "Verifying the Inverter Board and Backlight Lamp" on page 8-183.
3. If the display lights-up when the instrument power is turned on, but the display remains blank, continue with the following:
  - a. Connect an external VGA monitor to the rear panel VGA output connector on the instrument.
  - b. If the external VGA monitor is blank, the A14 display interface board assembly is probably defective.

Remove the top cover of the instrument to facilitate troubleshooting.

- c. If the external VGA monitor is functioning as expected, verify that the LCD data cable (W10) is properly connecting the A14 display interface board to the LCD display. If the cable is properly connected and the LCD display is blank, the most probable cause is the A15 LCD display. To replace the LCD display front panel assembly refer to Figure 6-1.

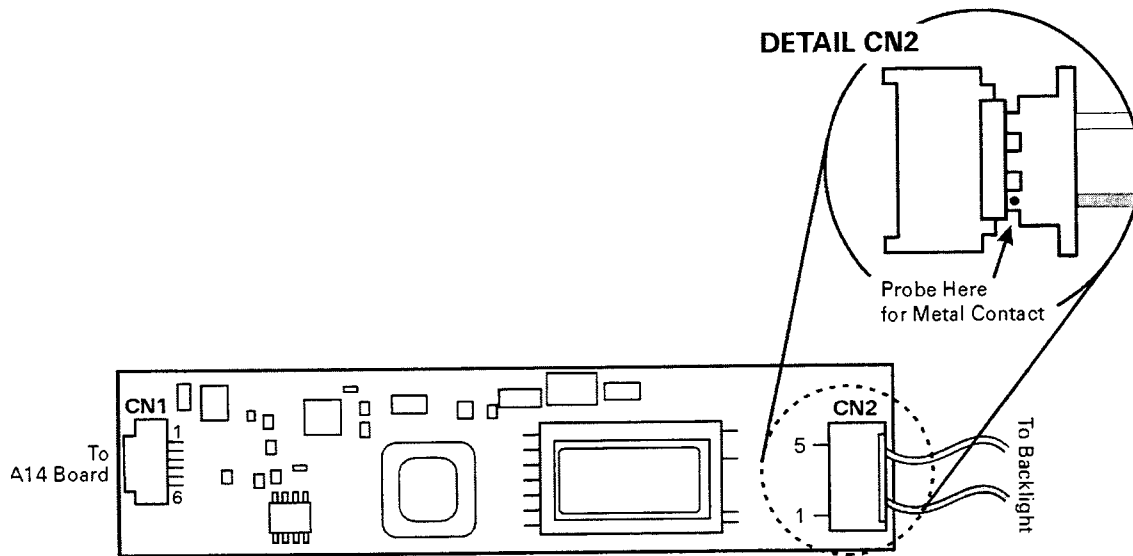
## VERIFYING THE INVERTER BOARD AND BACKLIGHT LAMP

**WARNING** High voltage is present on the A16 inverter board. Use caution when measuring signals and voltages on the board.

Remove the top cover of the instrument to facilitate troubleshooting.

Using Figure 8-39 as a reference, measure the signals and voltages indicated in Table 8-28. If the signals and voltages measure correctly, the inverter board is functioning properly.

**Figure 8-39. A16 Inverter Board Test Point Locations**



sa614d

**Table 8-28. A16 Inverter Board, Voltages and Signals**

Test Point	Signal or Voltage	Test Point	Signal or Voltage
CN1 pin 1	+5.1 Vdc	CN1 pin 5	0 V (ground)
CN1 pin 2	+5.1 Vdc	CN1 pin 6	0 V to +5.1 V
CN1 pin 3	39 mV (after completion of power-on)	CN2 pin 1 <sup>1</sup>	+900 V peak sinewave @ 38 kHz
CN1 pin 4	0 V (ground)	CN2 pin 5	ac neutral (referenced to pin 1)

1. This signal is referenced to chassis ground. For easier access to pin 1 of CN2, slide the plug slightly out of the fully seated position. This will expose a small piece of metal electrically connected to pin 1. (See detail CN2).

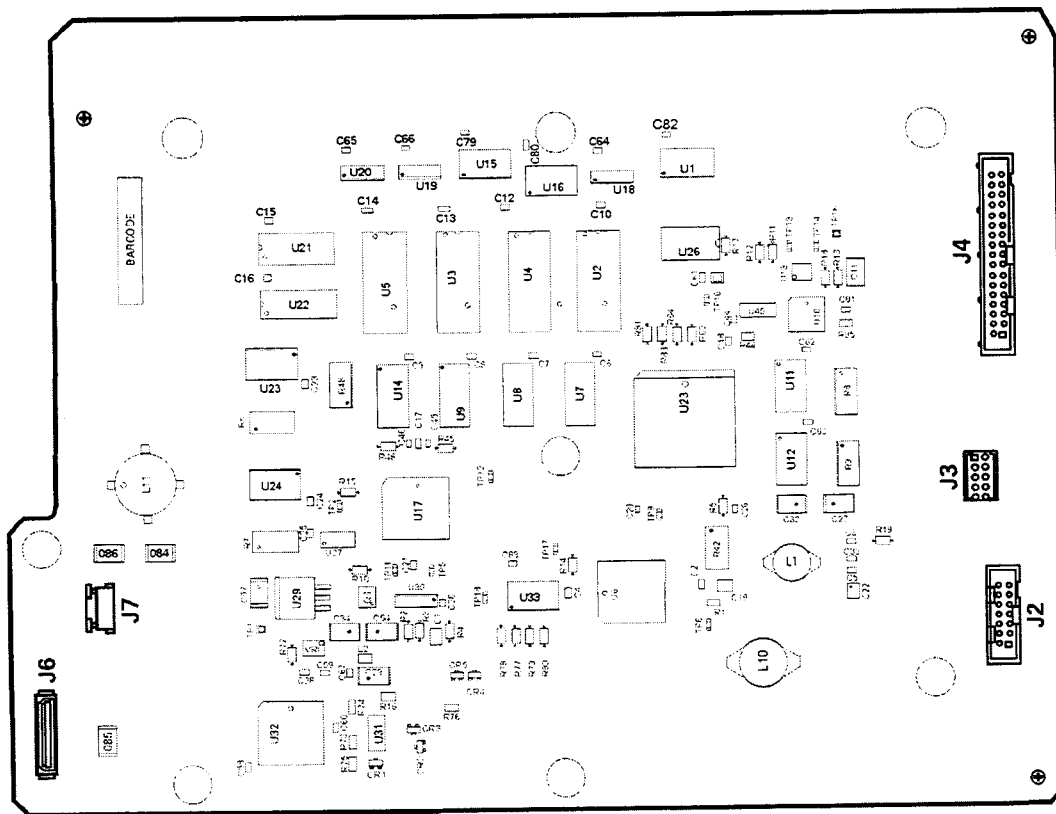
After measuring points CN1 and CN2, match the results and perform the rework as indicated in the action column in Table 8-29.

**Table 8-29. Inverter Board Troubleshooting Steps**

Input (CN1)	Output (CN2)	Action
Good	Good	Replace the backlight lamp. Refer to page 8-36.
Good	Bad	Replace the A16 inverter.
Bad	Bad	Replace the flat flex cable (W11), or the A14 display interface board.

Successful troubleshooting and repair should result in the following. When the instrument is turned on the LCD display should operate normally, or at least be illuminated.

**Figure 8-40. A14 Display Interface Board Connectors**



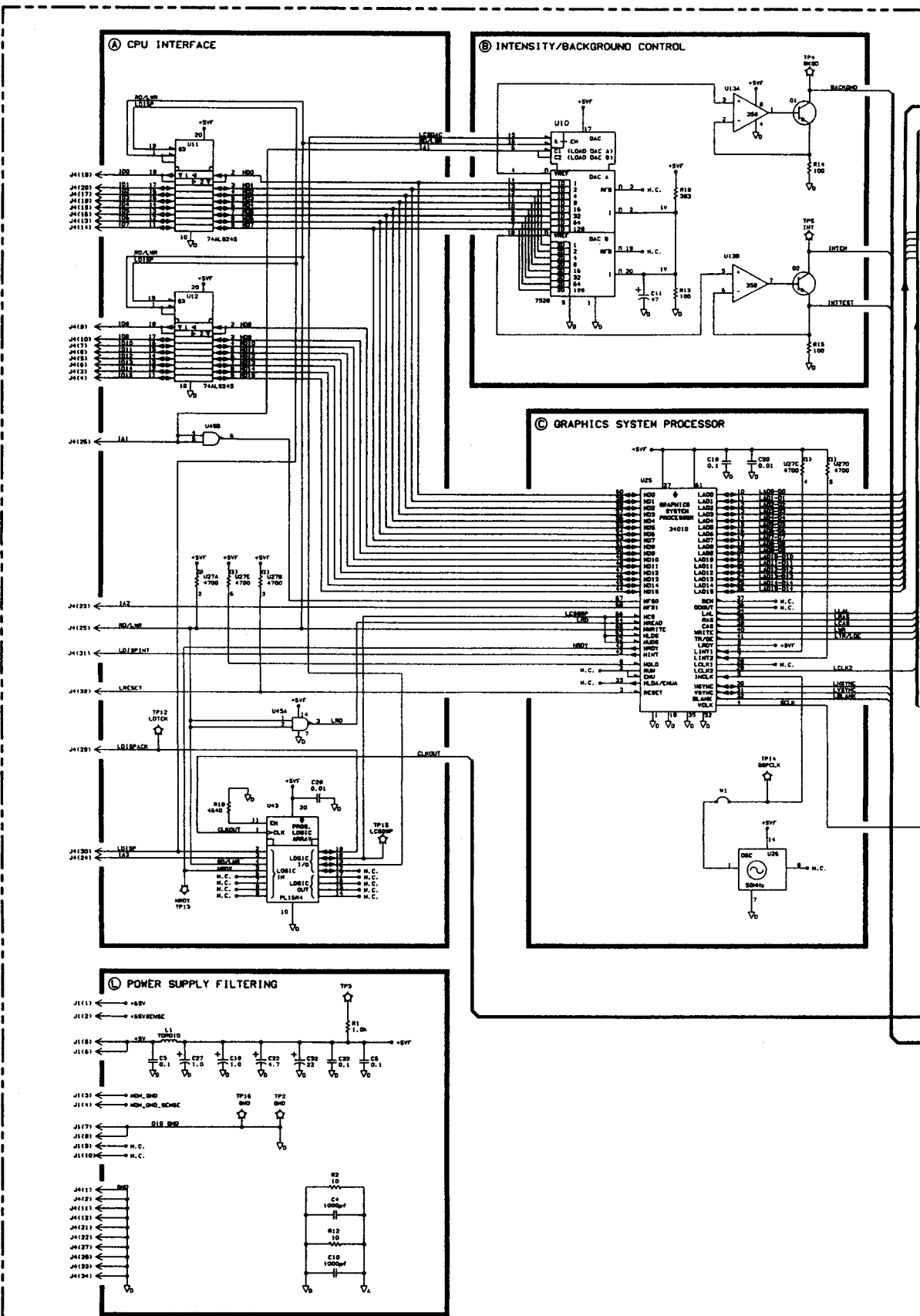
sa66d

## REFERENCE INFORMATION FOR TROUBLESHOOTING

**Table 8-30. A14J4 Pinouts (Display Interface)**

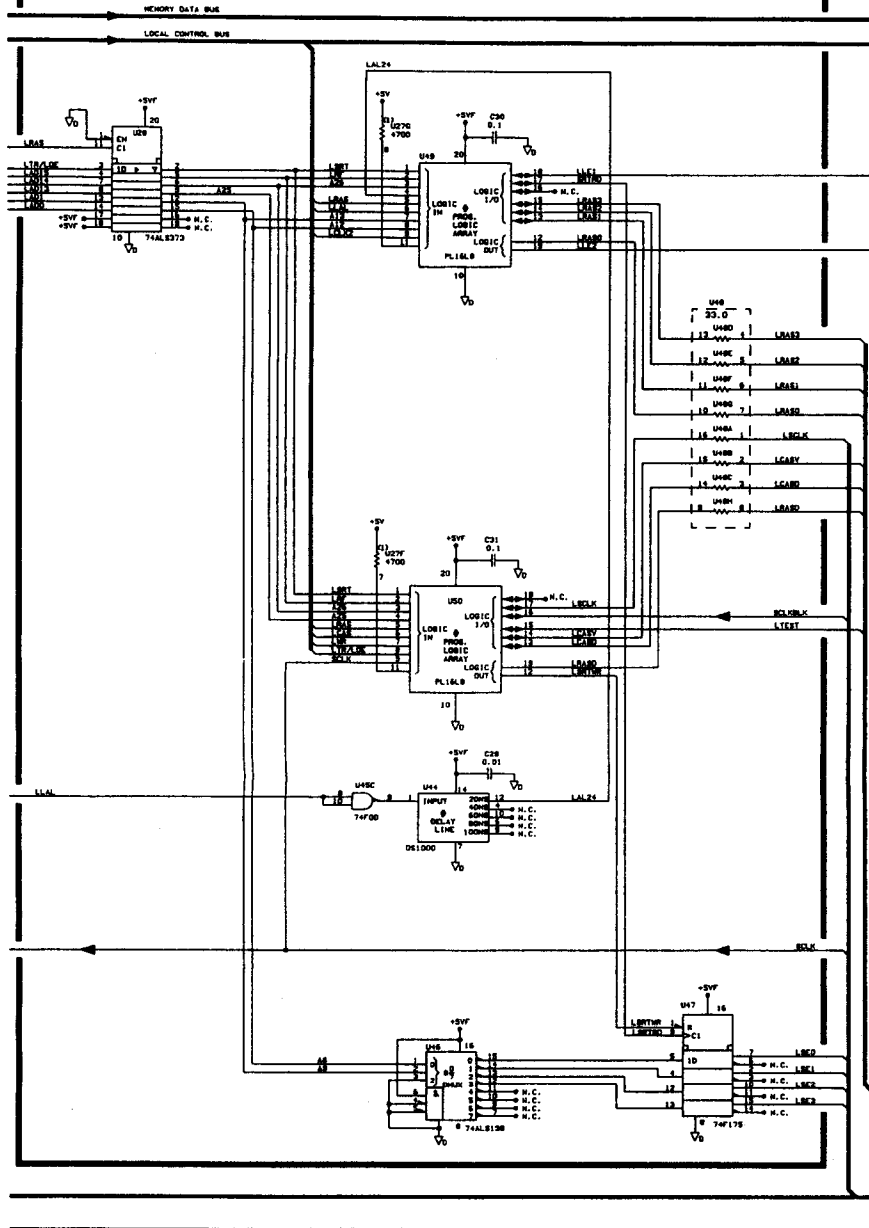
J4 Pin	SIGNAL	I/O
1	GRD	I
2	GRD	I
3	ID14	I/O
4	ID15	I/O
5	ID12	I/O
6	ID13	I/O
7	ID10	I/O
8	ID11	I/O
9	ID8	I/O
10	ID9	I/O
11	GRD	I
12	GRD	I
13	OD6	I/O
14	ID7	I/O
15	ID4	I/O
16	ID5	I/O
17	OD2	I/O
18	ID3	I/O
19	ID0	I/O
20	ID1	I/O
21	GRD	I
22	GRD	I
23	IA2	I
24	IA3	I
25	RD/LWR	I
26	IA1	I
27	GRD	I
28	GRD	I
29	LDISPACK	O
30	LDISP	I
31	LDISPINT	O
32	LRESET	I
33	GND	I
34	GND	I



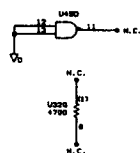


1 of 3 Left Side of Drawing

① MEMORY DECODING

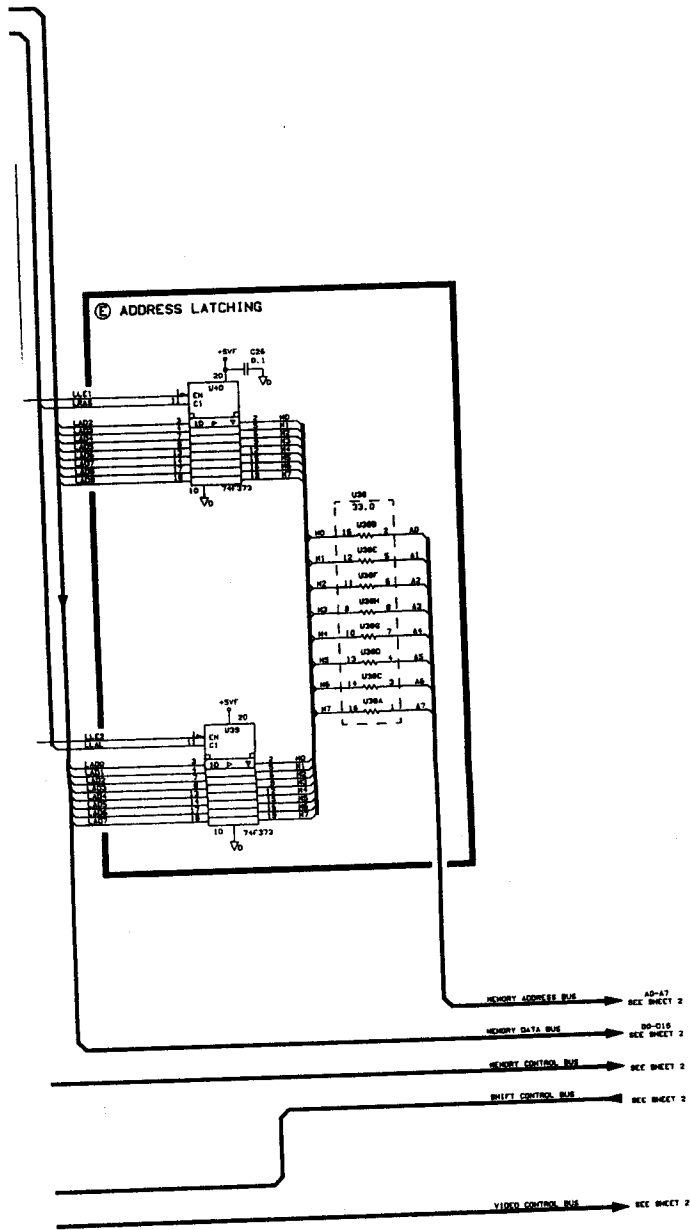


NOT USED



- NOTES: UNLESS OTHERWISE SPECIFIED.  
 1. ALL RESISTOR VALUES ARE IN OHMS.  
 2. ALL CAPACITOR VALUES ARE IN MICROFARADS.  
 3. ALL DIMENSION VALUES ARE IN DECIMETERS.

REFERENCE DESIGNATORS	
LAST USED	NOT USED
C30	
C31	
C32	
L1	
R1	
R2	
R3	
R4	
R5	
R6	
R7	
R8	
R9	
R10	
R11	
R12	
R13	
R14	
R15	
R16	
R17	
R18	
R19	
R20	
R21	
R22	
R23	
R24	
R25	
R26	
R27	
R28	
R29	
R30	
R31	
R32	
R33	
R34	
R35	
R36	
R37	
R38	
R39	
R40	
R41	
R42	
R43	
R44	
R45	
R46	
R47	
R48	
R49	
R50	
R51	
R52	
R53	
R54	
R55	
R56	
R57	
R58	
R59	
R60	
R61	
R62	
R63	
R64	
R65	
R66	
R67	
R68	
R69	
R70	
R71	
R72	
R73	
R74	
R75	
R76	
R77	
R78	
R79	
R80	
R81	
R82	
R83	
R84	
R85	
R86	
R87	
R88	
R89	
R90	
R91	
R92	
R93	
R94	
R95	
R96	
R97	
R98	
R99	
R100	
U48D	
U49D	
U50D	
U51D	
U52D	
U53D	
U54D	
U55D	
U56D	
U57D	
U58D	
U59D	
U60D	
U61D	
U62D	
U63D	
U64D	
U65D	
U66D	
U67D	
U68D	
U69D	
U70D	
U71D	
U72D	
U73D	
U74D	
U75D	
U76D	
U77D	
U78D	
U79D	
U80D	
U81D	
U82D	
U83D	
U84D	
U85D	
U86D	
U87D	
U88D	
U89D	
U90D	
U91D	
U92D	
U93D	
U94D	
U95D	
U96D	
U97D	
U98D	
U99D	
U100D	



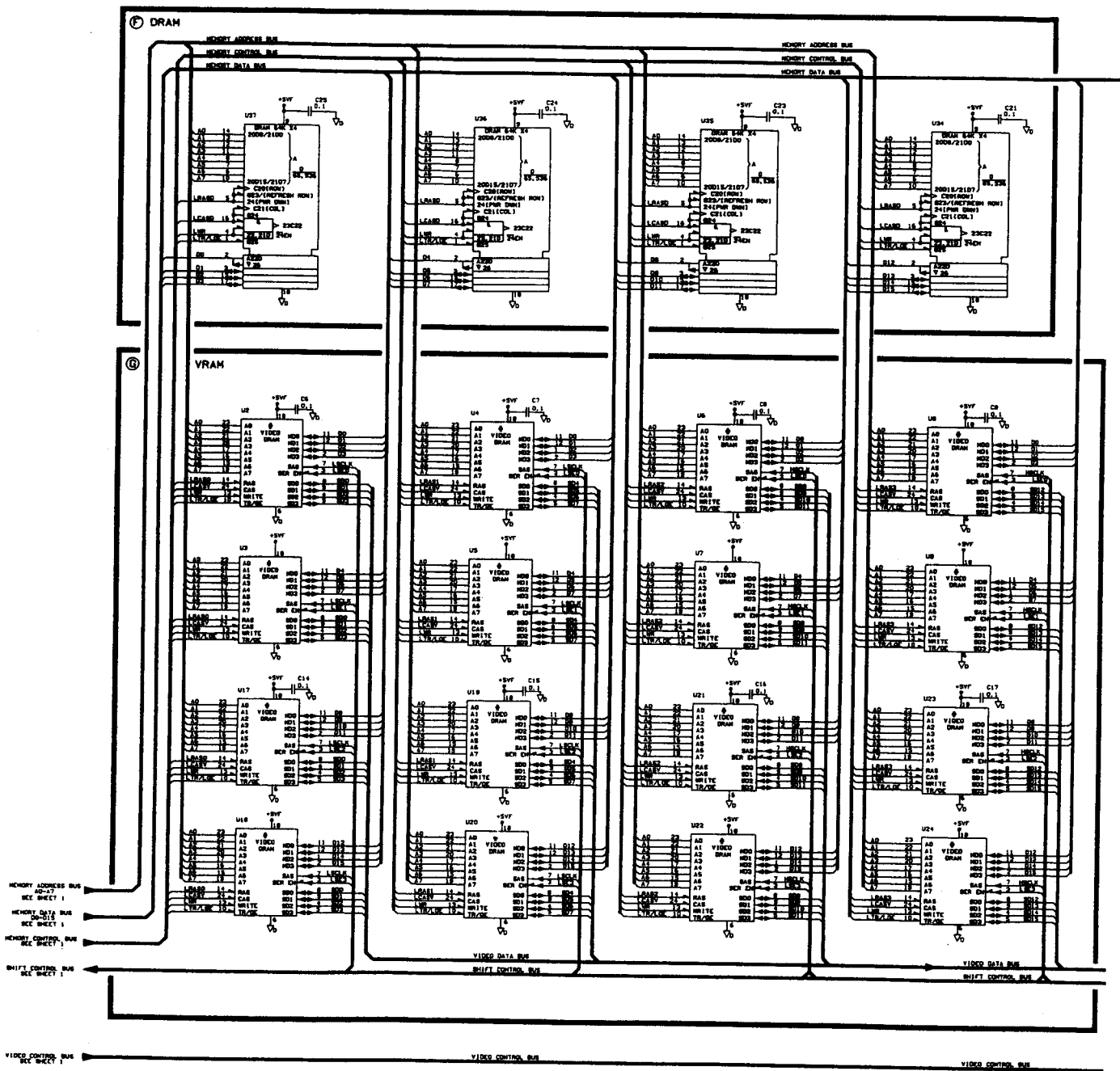
# A14 DISPLAY INTERFACE

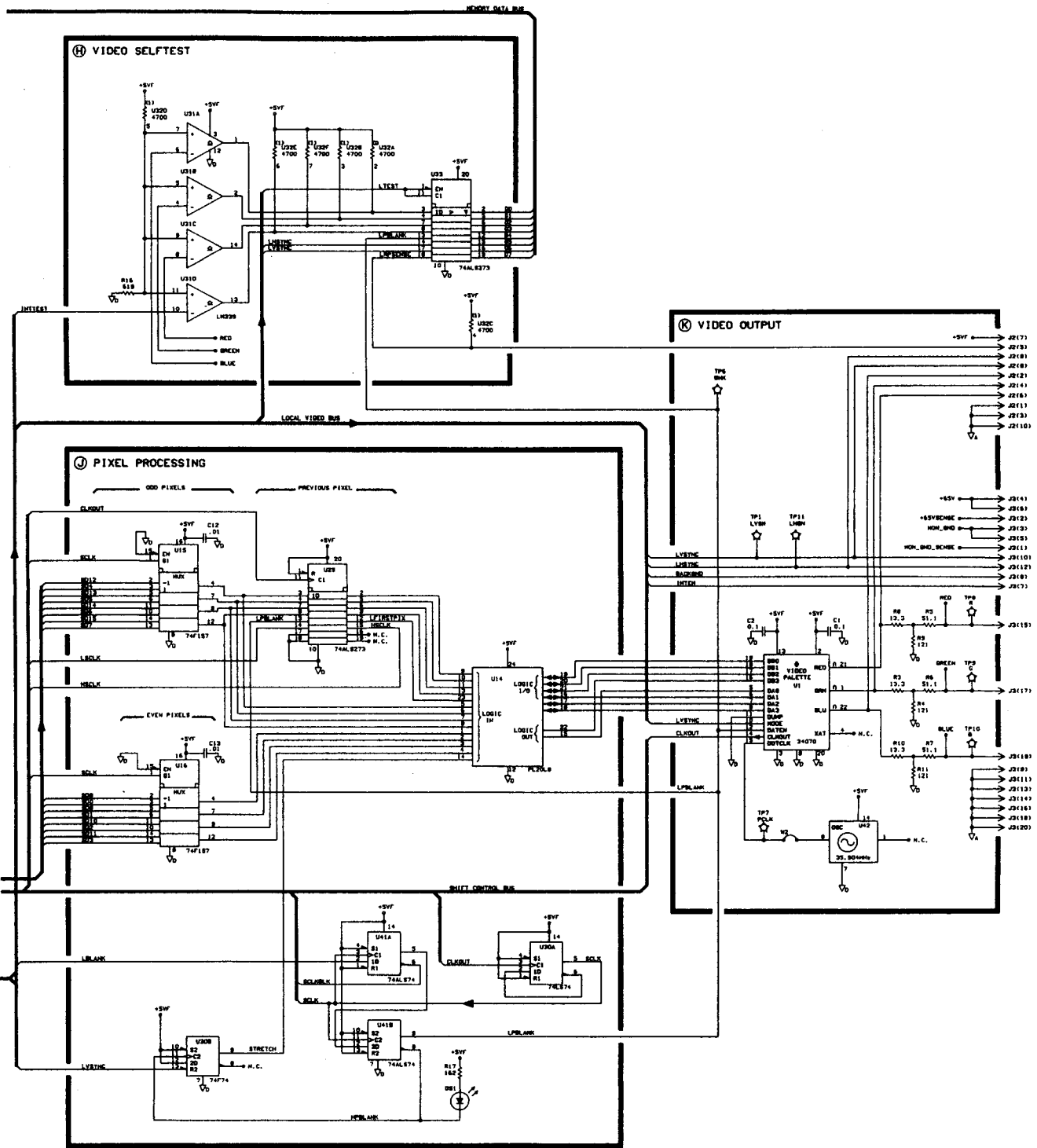
## 08757-60065

3 of 3 Right Side of Drawing

A14 Display Interface, Schematic Diagram (1 of 2)







2 of 2 Right Side of Drawing

**A14 DISPLAY INTERFACE**  
**08757-60065**

A14 Display Interface, Schematic Diagram (2 of 2)

---

## A15 LCD DISPLAY

---

**NOTE** The information in this section is specific to instruments with an LCD display. Unless otherwise noted, this information does not apply to instruments with CRT displays. See the Manual Backdating chapter (blue tab) for information on the A15 assembly associated with the CRT display.

---

This section documents the A15 LCD display, it also contains the disassembly and reassembly procedures for the display front panel assembly. See “Display Front Panel Assembly” on page 8-190.

### CIRCUIT DESCRIPTION

The A15 LCD display assembly is an 8.4-inch liquid crystal display (LCD) with associated drive circuitry. It receives a +3.3 V power supply from the A14 display interface, along with the voltage generated from the A16 backlight inverter. The A15 receives the following signals from the A14 display interface:

- digital horizontal sync
- digital vertical sync
- digital blanking
- data clock
- digital red video
- digital green video
- digital blue video

The A15 LCD display assembly includes the backlight lamp. The lamp attaches to the LCD display frame but is electrically separate. The backlight is powered by a separate connection to the A16 inverter. See Figure 8-41 on page 8-190 for details.

### ADJUSTMENTS AND REPAIR

There are no adjustments to be made on this assembly.

Component level repair of the A14 board is not supported. For this reason, a schematic and detailed parts list is not provided. If the A14 display interface board fails, it should be replaced.

### TROUBLESHOOTING IMAGE PROBLEMS

The following information assumes that the display is illuminated when the instrument is turned on. If the display remains dark, dim, or blank, refer to the A14 section, “Troubleshooting LCD Display Problems” on page 8-182.

## DISPLAY TROUBLESHOOTING PROCEDURE

The display should be bright with annotations and the text readable. This procedure allows you to check for non-functioning pixels and other problems.

1. Activate the default colors: Press **[DISPLAY]**, **[ADJUST DISPLAY]**, **[DEFAULT COLORS]**. If this does not correct the color problem, proceed to step 2.
2. Exercise the display test patterns by referring to “Display Test Patterns” on page 8-189. Check for damaged pixels; look for the symptoms described in “How to Identify a Faulty Display,” and other serious abnormalities.

If the A15 LCD display is defective, replace the display front panel assembly. Refer to Figure 6-1.

### WHAT IS A FAULTY PIXEL?

A pixel is a picture element that combines to create an image on the display. They are about the size of a small pin point. Damaged pixels can be either “permanently on” or “permanently off.”

- A “permanently on” pixel is red, green, or blue and is always displayed regardless of the display setting. It will be visible on a dark background.
- A “permanently off” pixel is always dark and is displayed against a background of its own color.

### HOW TO IDENTIFY A FAULTY DISPLAY

The display test has a sequence of red, green, blue, white, and black backgrounds. One or more of the following symptoms indicate a faulty display.

- complete rows or columns of “permanently on” or “permanently off” pixels
- more than five “permanently on” or “permanently off” pixels (not to exceed a maximum of two red or blue, or three green)
- two or more consecutive “permanently on” or “permanently off” pixels
- “permanently on” or “permanently off” pixels less than 6.5 mm apart

If any of these symptoms occur, replace the display.

## DISPLAY TEST PATTERNS

Test patterns are used in the factory for display adjustments, diagnostics, and troubleshooting. They may be used for field service as needed. Test patterns are executed by pressing the following keys: [PRESET], [SYSTEM], [MORE], [SERVICE], [DISPLAY], [TEST PATTERN], enter the test number.

**Table 8-31. Tests Pattern Descriptions**

Test Name	Description
Test Pat. 1	Displays an all white screen for verifying the light output of the A15 display and checks for color purity.
Test Pat. 2-4	Displays a red, green, and blue pattern for verifying the color purity of the display and also the ability to independently control each color.
Test Pat. 5	Displays an all black screen. This is used to check for stuck pixels.
Test Pat. 6	Displays a 16-step gray scale for verifying that the A14 display interface board can produce 16 different amplitudes of color (in this case, white). The output comes from the RAM on the GSP board, it is then split. The signal goes through a video DAC and then to an external monitor or through some buffer amplifiers and then to the internal LCD display. If the external display looks good but the internal display is bad, then the problem may be with the display or the cable connecting it to the display interface board. This pattern is also very useful when using an oscilloscope for troubleshooting. The staircase pattern it produces will quickly show missing or stuck data bits.
Test Pat. 7	Displays the following seven colors: Red, Yellow, Green, Cyan, Blue, Magenta and White.
Test Pat. 8	Displays a color rainbow pattern for showing the ability of the A14 display interface board to display 15 colors plus white. The numbers written below each bar indicate the tint number used to produce that bar (0 and 100=pure red, 33=pure green, 67=pure blue). This pattern is intended for use with an external display.
Test Pat. 9	Displays the three primary colors (Red, Green, and Blue) at four different intensity levels. You should see 16 color bands across the screen. Starting at the left side of the display the pattern is: Black, four bands of Red (each band increasing in intensity), Black, four bands of Green (each band increasing in intensity), Black, four bands of Blue (each band increasing in intensity), Black. If any one of the four bits for each color is missing, the display will not look as described.
Test Pat. 10	Displays a character set for showing the user all the different types and sizes of characters available. Three sets of characters are drawn in each of the three character sizes. 125 characters of each size are displayed. Characters 0 and 3 cannot be drawn and several others are control characters (such as carriage return and line feed).
Test Pat. 11	Displays a bandwidth pattern for verifying the bandwidth of the EXTERNAL display. It consists of multiple alternating white and black vertical stripes. Each stripe should be clearly visible. A limited bandwidth would smear these lines together. This is used to test the quality of the external monitor.
Test Pat. 12	Displays a repeating gray scale for troubleshooting, using an oscilloscope. It is similar to the 16 step gray scale but is repeated 32 times across the screen. Each of the 3 outputs of the video palette will then show 32 ramps (instead of one staircase) between each horizontal sync pulse. This pattern is used to troubleshoot the pixel processing circuit of the A14 display interface board.
Test Pat. 13	Displays a convergence pattern for measuring the accuracy of the color convergence of the external monitor.
Test Pat. 14-15	Displays crosshatch and inverse crosshatch patterns for testing color convergence, linearization alignment. This is useful when aligning the LCD display in the bezel.

## DISPLAY FRONT PANEL ASSEMBLY

This section describes the disassembly and reassembly of the display front panel assembly. See Chapter 6 for associated part numbers.

---

**NOTE** Refer to “LCD and Keypad Removal and Installation Procedure” on page 8-38 for instruction on removing and installing the assembly into the instrument frame.

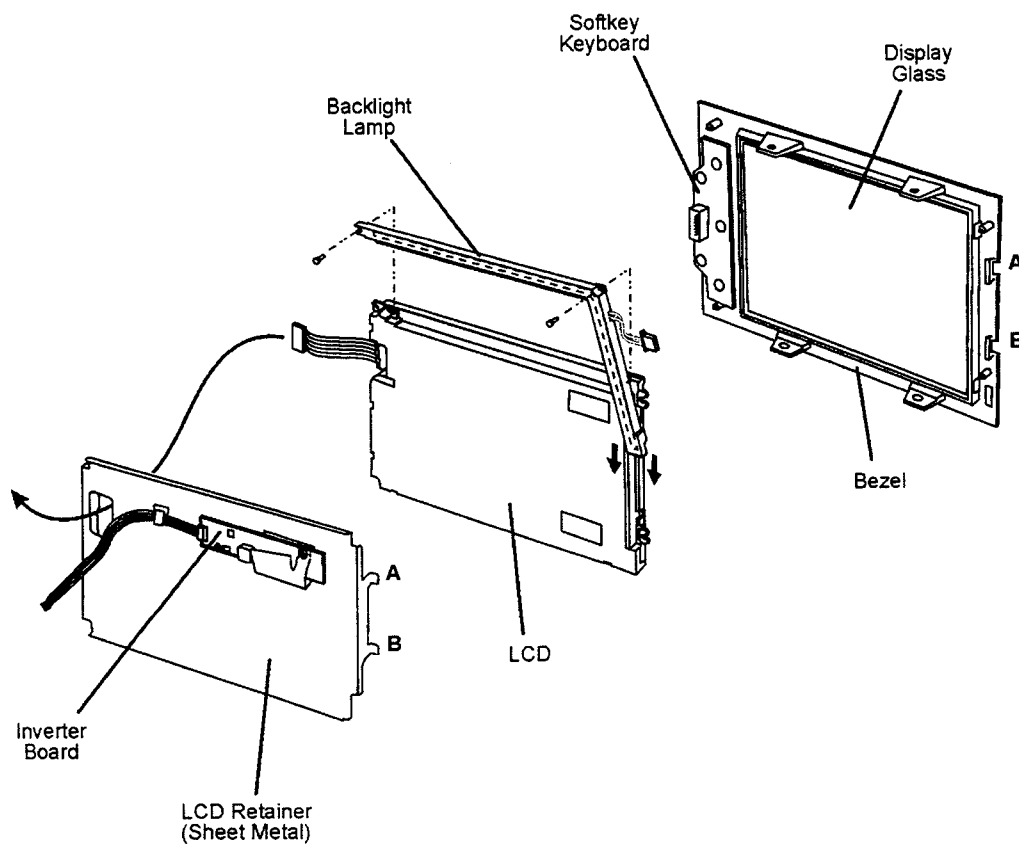
---

---

**NOTE** To avoid dust or dirt particles from getting in between the display glass and the display, do not completely remove the LCD display from the bezel.

---

**Figure 8-41. Display Front Panel Assembly Details**



sa67d

## **DISASSEMBLY PROCEDURE**

1. Disconnect the power cord.
2. Remove the front panel assembly. Refer to “LCD and Keypad Removal Procedure” on page 8-38 for further instructions.
3. Remove the two nuts behind the softkeys that secure the sheet metal LCD retainer.
4. Tilt the sheet metal LCD retainer up before sliding tabs A and B free.

---

**NOTE** To avoid dust or dirt particles from getting in between the display glass and the LCD, do not completely separate the display from the bezel. See Figure 8-41.

---

## **HELPFUL HINTS**

- When replacing the backlight lamp, remove the two screws holding the lamp in place on the LCD. Tilt the LCD in the bezel just enough to allow the lamp to be replaced.
- If the inverter is replaced be sure the plastic cover is held securely in place by one of the mounting screws.
- If the LCD is to be replaced, the complete display front panel assembly should be replaced.

## **ASSEMBLY PROCEDURE**

1. Reverse the order of the disassembly procedure.





---

## A16 INVERTER

---

**NOTE** The information in this section is specific to instruments with an LCD display. Unless otherwise noted, this information does not apply to instruments with CRT displays. See the Manual Backdating chapter (blue tab) for information on the A16 assembly associated with the CRT display.

---

### CIRCUIT DESCRIPTION

The A16 inverter assembly supplies the ac voltage for the backlight lamp in the A15 LCD display assembly. This assembly takes the +5 DSP and converts it to approximately 680 Vac steady state. At start-up, the voltage can reach up to 1.5 kVac. There are two control lines:

- digital ON/OFF
- analog brightness
  - 100 % intensity is 0 V
  - 50 % intensity is 4.5 V

---

**WARNING** High voltage is present on the inverter board. Be careful when measuring signals and voltages on the board.

**Make sure the plastic cover on the inverter board is held securely in place by one of the mounting screws. This cover protects against inadvertent contact with the high voltage generated by the inverter.**

---

Component level repair of the A14 board is not supported. For this reason, a schematic and detailed parts list is not provided. If the A14 display interface board fails, it should be replaced.

For A16 inverter troubleshooting information, refer to the A14 section, “Verifying the Inverter Board and Backlight lamp” on page 8-183.



## **MANUAL BACKDATING**

The information in the Manual Backdating chapter is for use with the CRT based 8757D. If you are using an instrument with a CRT you may want to remove the contents of the Manual Backdating chapter and place it back into the appropriate sections. Refer to the page number.



# HP 8757D Scalar Network Analyzer

## CONTENTS

<b>Chapter 4. Performance Tests</b>	
CONTENTS .....	4-1
INTRODUCTION .....	4-1
EQUIPMENT REQUIRED .....	4-1
PERFORMANCE TEST RECORD CARD .....	4-1
<b>Self-Test</b> .....	4-3
<b>Dynamic Power Accuracy</b> .....	4-4
Alternative Dynamic Power Accuracy Test .....	4-4
<b>Modulator Drive</b> .....	4-5
DESCRIPTION AND PROCEDURE .....	4-5
Voltage Amplitude .....	4-5
Frequency Accuracy and Symmetry .....	4-6
IF THE INSTRUMENT FAILS THIS TEST .....	4-6
<b>HP Interface Bus and 8757 Interface</b> .....	4-7
DESCRIPTION AND PROCEDURE .....	4-7
IF THE INSTRUMENT FAILS THIS TEST .....	4-7
<b>Performance Test Record</b> .....	4-8
<b>Performance Tests Option 002 only</b> .....	4-9
<b>Chapter 5. Adjustments</b>	
CONTENTS .....	5-1
INTRODUCTION .....	5-1
SAFETY CONSIDERATIONS .....	5-1
EQUIPMENT REQUIRED .....	5-2
RELATED ADJUSTMENTS .....	5-2
LOCATION OF TEST POINTS AND ADJUSTMENT CONTROLS .....	5-2
ADJUSTING CALIBRATION CONSTANTS .....	5-3
<b>Power Supply Adjustments</b> .....	5-4
DESCRIPTION AND PROCEDURE .....	5-4
<b>Sweep DAC Gain Adjustment</b> .....	5-7
DESCRIPTION AND PROCEDURE .....	5-7
<b>Display Intensity Adjustments</b> .....	5-9
BACKGROUND ADJUSTMENT .....	5-9
DESCRIPTION AND PROCEDURE .....	5-9
<b>Nominal Intensity Adjustment</b> .....	5-10
DESCRIPTION AND PROCEDURE .....	5-10
<b>Minimum Intensity Adjustment</b> .....	5-11
DESCRIPTION AND PROCEDURE .....	5-11
<b>Vertical Position And Focus Adjustment</b> .....	5-12
DESCRIPTION AND PROCEDURE .....	5-12
<b>Chapter 6. Replaceable Parts</b>	
INTRODUCTION .....	6-1

PARTS LIST ORGANIZATION .....	6-1
ORDERING INFORMATION .....	6-1
RESTORED EXCHANGE ASSEMBLIES .....	6-2
<b>Chapter 7. Instrument History</b>	
INTRODUCTION .....	7-1
<b>Chapter 8. Troubleshooting</b>	
INTRODUCTION .....	8-1
SCHEMATIC DIAGRAM NOTES .....	8-1
RECOMMENDED TEST EQUIPMENT .....	8-1
WIRING LIST AND MNEMONICS .....	8-1
TROUBLESHOOTING .....	8-1
BASIC COMPONENT SYMBOLOGY .....	8-3
SELF-TESTS .....	8-5
Error Codes .....	8-5
Self-Test Sequence .....	8-7
Instrument Verify .....	8-8
Forced Diagnostic Tests .....	8-8
Calibration Constants and Checksum Errors .....	8-9
Other Error Messages .....	8-10
Power Calibration Error Messages .....	8-10
Notes on Self-tests .....	8-11
OPERATOR-INITIATED DIAGNOSTIC TESTS .....	8-12
Hexadecimal Tests .....	8-12
OVERALL INSTRUMENT DESCRIPTION .....	8-18
Overview .....	8-18
A7/A8/A9/A10 Log Amplifiers .....	8-18
A4 Analog-to-Digital Converter (ADC) .....	8-19
A3 Central Processing Unit (CPU) .....	8-19
A14 Display Interface, A15 Display .....	8-20
A16 RGB Interface .....	8-20
A1/A2 Front Panel .....	8-20
A6 HP-IB .....	8-20
A5 Modulator Driver .....	8-21
A12 Power Supply .....	8-21
OVERALL INSTRUMENT TROUBLESHOOTING .....	8-21
Line Power and Power Supplies .....	8-22
Self-Test and Error Codes .....	8-22
Front Panel .....	8-23
Display .....	8-23
Data Acquisition and Sweep Comparators .....	8-23
Analog-to-Digital Conversion and Analog Accuracy .....	8-24
HP-IB .....	8-25
Modulation .....	8-25
<b>A1 Front Panel and A2 Front Panel Interface</b> .....	8-31
CIRCUIT DESCRIPTION .....	8-31

A. ADDRESS DECODER/RESET .....	8-31
B. REAL TIME CLOCK .....	8-31
C. POWER SUPPLY .....	8-31
D. RPG INTERFACE, RPG .....	8-32
E. KEYBOARD INTERFACE, KEYBOARD .....	8-32
F. DETECTOR BIAS/CONTROL .....	8-33
H. CONTROL REGISTERS .....	8-33
J. FRONT PANEL STATUS/INTERRUPT .....	8-33
K, L. EEPROM DATA SELECT / EEPROM CLOCK GENERATOR .....	8-33
DIAGNOSTIC TESTS .....	8-33
READ KEY (FORCED ENTRY: CLOSE A3S1-A AND A3S1-C) .....	8-34
CYCLE (FORCED ENTRY: CLOSE A3S1-C) .....	8-34
LEDS .....	8-34
PRESET DISABLE .....	8-35
BASIC CHECKS .....	8-36
KEYBOARD AND INSTRUMENT BUS VERIFICATION .....	8-36
LEDS .....	8-37
RPG (ROTARY PULSE GENERATOR) .....	8-37
FRONT PANEL REMOVAL PROCEDURE .....	8-38
A1 FRONT PANEL/A2 FRONT PANEL INTERFACE, SCHEMATIC DIAGRAM (1 OF 2)	
A1 FRONT PANEL/A2 FRONT PANEL INTERFACE, SCHEMATIC DIAGRAM (2 OF 2)	
<b>A3 Central Processing Unit (CPU) .....</b>	<b>8-49</b>
CIRCUIT DESCRIPTION .....	8-49
A. CLOCK .....	8-49
B. POWER-ON/PRESET .....	8-49
C. STATUS/INTERRUPT .....	8-49
D. MICROPROCESSOR .....	8-50
E. ADDRESS DECODER .....	8-51
F. ROM .....	8-51
G. EEPROM .....	8-51
H. RAM .....	8-52
J. I/O TIMING .....	8-52
K. TIMER .....	8-53
L. INSTRUMENT BUS INTERFACE .....	8-53
M. POWER SUPPLY FILTERING .....	8-53
<b>Diagnostic Tests</b> .....	8-54
CPU READ/WRITE CYCLE (Forced Diagnostic Test Only) .....	8-55
OTHER TESTS .....	8-56
<b>A3 Troubleshooting</b> .....	<b>8-57</b>
BASIC CHECKS .....	8-57
SELF-TESTS .....	8-57
PRIMARY ERROR CODES .....	8-58
1111 (Error Code 15) or Unstable or Flashing Display:	
Microprocessor Kernel Failure .....	8-58
<b>ROM Signatures</b> .....	8-62

1110 (Error Code 14) — ROM Checksum .....	8-63
1101 (Error Code 13) —RAM Failure .....	8-63
1100 (Error Code 12) —Power Supply Failure .....	8-63
1011 (Error Code 11) —Instrument Bus Failure .....	8-64
1010 —0011 (Error Codes 10-3) —Display Interface Failure .....	8-64
0010 (Error Code 2) —Interrupt Failure .....	8-64
0001 (Error Code 1) —Instrument Verify Failures .....	8-65
0000 (Error Code 0) .....	8-65
FREE RUN MODE .....	8-66
A3 CENTRAL PROCESSING UNIT (CPU), SCHEMATIC DIAGRAM	
<b>A4 Analog-to-Digital Converter (ADC)</b> .....	8-75
CIRCUIT DESCRIPTION .....	8-75
A. ADDRESS DECODER .....	8-75
B. CONTROL DECODER .....	8-75
C. STOP SWEEP .....	8-76
D. DETECTOR CONTROL .....	8-76
E. SWEEP DAC .....	8-76
F. SWEEP BUFFER .....	8-77
G. SWEEP COMPARATORS .....	8-77
H. SAMPLE AND HOLD .....	8-78
I. ANALOG MULTIPLEXER .....	8-78
J. ADC .....	8-78
K. OUTPUT DATA REGISTERS .....	8-79
L. DATA READY .....	8-79
O. BLANK/MARKER DETECTOR .....	8-80
M. STATUS BUFFER .....	8-81
N. INTERRUPT LOGIC .....	8-81
P. STATUS LOGIC .....	8-81
Q. POWER SUPPLY FILTERING .....	8-82
<b>A4 Diagnostic Tests</b> .....	8-83
<b>A4 Troubleshooting</b> .....	8-93
BASIC CHECKS .....	8-93
SELF-TEST AND ERROR MESSAGES .....	8-93
CIRCUITS NOT CHECKED BY SELF-TESTS .....	8-94
Sweep In .....	8-94
Stop Sweep .....	8-94
ADC IN and DAC OUT .....	8-94
Logger Sample/Hold Circuits .....	8-94
BLOCK-BY-BLOCK TROUBLESHOOTING .....	8-94
A. Address Decoder .....	8-94
B. Control Decoder .....	8-95
C. Stop Sweep .....	8-95
D. Detector Control .....	8-95
E. Sweep DAC .....	8-95
F. Sweep Buffer .....	8-95
G. Sweep Comparator .....	8-95



H. Sample/Hold .....	8-96
I, J, K, L. Data Acquisition .....	8-96
N, M, P. Interrupt and Status .....	8-96
O. Blank/Marker Detector .....	8-96
A4 ANALOG TO DIGITAL CONVERTER (ADC), SCHEMATIC DIAGRAM (1 OF 2)	
A4 ANALOG TO DIGITAL CONVERTER (ADC), SCHEMATIC DIAGRAM (2 OF 2)	
<b>A5 Modulator Driver Standard Instrument Only</b> .....	8-111
CIRCUIT DESCRIPTION .....	8-111
A. OSCILLATOR/DRIVER .....	8-111
B. AMPLIFIER/BUFFER .....	8-111
C. POWER SUPPLIES .....	8-111
<b>A5 Troubleshooting Standard Instrument Only</b> .....	8-112
BASIC CHECKS .....	8-112
MODULATION ON/OFF CONTROL .....	8-112
FREQUENCY .....	8-112
AMPLIFIER/BUFFER .....	8-112
<b>A5 CAL/MOD Board Assembly Option 002 Only</b> .....	8-113
CIRCUIT DESCRIPTION .....	8-113
TROUBLESHOOTING MODULATION PROBLEMS .....	8-113
TROUBLESHOOTING THE 50MHZ CALIBRATOR .....	8-113
A5 MODULATOR DRIVER, SCHEMATIC DIAGRAM	
<b>A6 HP-IB Assembly</b> .....	8-121
CIRCUIT DESCRIPTION .....	8-121
A. ADDRESS DECODER .....	8-121
B. HP INTERFACE BUS .....	8-122
C. 8757 SYSTEM INTERFACE .....	8-123
D. POWER SUPPLY FILTERING .....	8-123
<b>A6 Troubleshooting</b> .....	8-124
BASIC CHECKS .....	8-124
HP-IB DIAGNOSTIC TESTS .....	8-124
CHECKING LINE ACTIVITY .....	8-124
INSTRUMENT BUS FAILURES .....	8-126
<b>A7/A8/A9/A10 Log Amplifiers</b> .....	8-133
CIRCUIT DESCRIPTION .....	8-133
A. INPUT AMPLIFIER .....	8-133
B. 13/26 DB AMPLIFIER .....	8-133
C. 13 DB GAIN STAGES .....	8-134
D. 13 DB ATTENUATION STAGES .....	8-134
E. 6.3V REFERENCE/BIAS .....	8-134
F. LOGGER .....	8-134
G. MULTIPLEXER/RECTIFIER .....	8-134
H. 5 KHZ LOWPASS FILTER .....	8-135
I. POWER SUPPLY FILTERING .....	8-135
<b>A7/A8/A9/A10 Troubleshooting</b> .....	8-136
GENERAL TROUBLESHOOTING .....	8-136
Basic Checks .....	8-137

Assembly Troubleshooting .....	8-137
Noise Problems .....	8-139
A7/A8/A9/A10 LOG AMPLIFIERS, SCHEMATIC DIAGRAM	
<b>A12 Power Supply</b> .....	8-153
CIRCUIT DESCRIPTION .....	8-153
POWER LINE MODULE FL1, LINE SWITCH S1, THERMAL SWITCH S2, TRANSFORMER T1 .....	8-153
A. +5V RECTIFIER .....	8-154
B. OVERVOLTAGE PROTECTION .....	8-154
C. +5V REGULATOR .....	8-154
D. +5V REGULATOR (DISPLAY) .....	8-155
E. POWER FAILURE WARNING .....	8-155
F. ±15V RECTIFIER .....	8-155
H. +15V REGULATOR .....	8-155
J. +65V RECTIFIER .....	8-156
K. +65V REGULATOR .....	8-156
L. SUPPLY FAILURE INDICATOR .....	8-157
M. -15V REGULATOR .....	8-157
N. -12.6V REGULATOR .....	8-157
P. GROUNDS .....	8-158
<b>A12 Troubleshooting</b> .....	8-159
BASIC CHECKS .....	8-159
LINE POWER .....	8-159
TRANSFORMER .....	8-159
RECTIFIERS .....	8-159
ADJUSTABLE REGULATORS .....	8-159
+65 VOLT REGULATOR .....	8-160
A12 POWER SUPPLY, SCHEMATIC DIAGRAM	
<b>A11 Motherboard and A13 Rear Panel</b> .....	8-169
A13 REAR PANEL, SCHEMATIC DIAGRAM	
<b>A14 Display Interface Board</b> .....	8-181
CIRCUIT DESCRIPTION .....	8-181
A. CPU INTERFACE .....	8-181
B. INTENSITY / BACKGROUND CONTROL .....	8-182
C. GRAPHICS SYSTEM PROCESSOR (GSP) .....	8-182
D. MEMORY DECODING .....	8-182
E. ADDRESS LATCHING .....	8-183
F. DRAM .....	8-183
G. VRAM .....	8-183
H. PIXEL PROCESSING .....	8-184
J. VIDEO OUTPUT .....	8-184
K. VIDEO SELF-TEST .....	8-184
L. POWER SUPPLY FILTERING .....	8-185
<b>A14 Adjustments and A14 Diagnostic Tests</b> .....	8-186
ADJUSTMENTS .....	8-186

Background Adjustment .....	8-186
Nominal Intensity .....	8-187
Minimum Intensity .....	8-187
Test Patterns .....	8-187
DIAGNOSTIC TESTS .....	8-190
Display Test .....	8-190
Background and Intensity Ramps .....	8-190
Other Adjustments .....	8-191
FORCED DIAGNOSTIC TESTS .....	8-191
<b>A14 Troubleshooting</b> .....	8-194
BASIC CHECKS .....	8-194
ERROR CODE DESCRIPTION .....	8-195
1010 (Error Code 10) —Display Interface Failure .....	8-195
1001 (Error Code 9) —Display Interface DRAM Failure .....	8-195
1000 (Error Code 8) —DRAM Download Failure .....	8-197
0111 (Error Code 7) —DRAM Cell Test .....	8-198
0110 (Error Code 6) —VRAM .....	8-198
0101 (Error Code 5) —VRAM Cell Test .....	8-198
0100 (Error Code 4) —Video Control .....	8-199
0011 (Error Code 3) —R,G,B .....	8-199
0010 (Error Code 2) —INTERRUPT .....	8-199
No Error Code; But a Distorted, Blank, or Otherwise Incorrect Display .....	8-200
A14 DISPLAY INTERFACE, SCHEMATIC DIAGRAM (1 OF 2)	
A14 DISPLAY INTERFACE, SCHEMATIC DIAGRAM (2 OF 2)	
<b>A15 Display</b> .....	8-213
DESCRIPTION .....	8-213
<b>A15 Troubleshooting</b> .....	8-214
<b>A15 Adjustments</b> .....	8-214
VERTICAL POSITION AND FOCUS .....	8-214
<b>A15 Display Replacement Procedure</b> .....	8-215
REMOVING THE DISPLAY .....	8-215
CLEANING THE DISPLAY AND GLASS FILTER .....	8-216
<b>A16 Rear Panel Video Interface (RGB Interface)</b> .....	8-217
DESCRIPTION .....	8-217
<b>A16 Troubleshooting</b> .....	8-218
BASIC CHECKS .....	8-218
R, G, B BUFFER AMPLIFIERS .....	8-218
SYNC/RECTIFIER .....	8-218
A16 RGB INTERFACE SCHEMATIC DIAGRAM	

# HP 8757D Scalar Network Analyzer

## FIGURES

Figure 4-1. Voltage Amplitude Test Setup .....	4-5
Figure 4-2. Frequency Accuracy and Symmetry Test Setup .....	4-6
Figure 4-3. HP Interface Bus and 8757 System Interface Test Setup .....	4-7
Figure 5-1. Power Supply Adjustments Set-up .....	5-4
Figure 5-2. A12 Assembly Location .....	5-5
Figure 5-3. Power Supply Adjustment Locations .....	5-6
Figure 5-4. Sweep DAC Gain Adjustment Set-up .....	5-7
Figure 5-5. A4 Assembly Location .....	5-8
Figure 5-6. Sweep DAC Gain Adjustment Locations .....	5-8
Figure 5-7. Nominal Intensity Adjustment Set-up .....	5-10
Figure 5-8. Minimum Intensity Adjustment Set-up .....	5-11
Figure 5-9. Vertical Position Adjustment Control .....	5-12
Figure 6-1. Module Exchange Program .....	6-3
Figure 8-1. Schematic Diagram Notes (1 of 2) .....	8-3
Figure 8-1. Schematic Diagram Notes (2 of 2) .....	8-4
Figure 8-2. Hexadecimal Entry Keys .....	8-13
Figure 8-3. Hex Data Rotate Waveforms .....	8-15
Figure 8-4. 8757D Simplified Block Diagram .....	8-27
Figure 8-5. 8757D Overall Troubleshooting Block Diagram .....	8-29
Figure 8-6. Front Panel Cycle Test Waveforms .....	8-34
Figure 8-7. Front Panel Removal .....	8-38
Figure 8-8. W1-4 Detector Interface Cable Schematic .....	8-41
Figure 8-9. A1 Component Locations Diagram .....	8-44
Figure 8-10. A2 Component Locations Diagram .....	8-44
A1 Front Panel, Schematic Diagram	
A2 Front Panel Interface, Schematic Diagram	
Figure 8-12. CPU Read/Write Cycle .....	8-55
Figure 8-13. ASTRB/DTACK .....	8-67
Figure 8-14. A3 Component Locations Diagrams .....	8-72
A3 CPU, Schematic Diagram	
Figure 8-16. Detector Control Cycle Waveforms .....	8-84
Figure 8-17. Sweep Comparison Cycle Tests Waveforms .....	8-85
Figure 8-18. DAC Waveforms during A4 Ramp Test .....	8-87
Figure 8-19. A4 Channel Volts Tests .....	8-88
Figure 8-20. Timing of the A4 Data Ready Loop .....	8-90
Figure 8-21. Timing of the A4 Read Data Loop .....	8-92
Figure 8-22. A4 ADC Sweep-Related Waveforms (Sweep Time 150ms) .....	8-98
Figure 8-23. A4 Component Locations Diagram .....	8-106
A4 Analog to Digital (ADC) Schematic Diagram	
Figure 8-25. A5 Component Locations Diagram (Standard Only) .....	8-116
Figure 8-26. A5 Mod/Cal Block Diagram (option 002 only) .....	8-117
Figure 8-27. A5 Option 002 Test Point Location Diagram .....	8-118
A5 Modulator Driver, Schematic Diagram	
Figure 8-29. Instrument Bus Cycle .....	8-126
Figure 8-30. A6 Component Locations Diagram .....	8-130
Figure 8-31. A6 HP-IB, Schematic Diagram .....	8-131
Figure 8-32. Typical Waveforms at Selected Points with +10 dBm Applied to Detector (1 of 2) .....	8-144
Figure 8-32. Typical Waveforms at Selected Points with +10 dBm Applied to Detector (2 of 2) .....	8-145
Figure 8-33. A7/A8/A9/A10 Component Locations Diagram .....	8-150
A7/A8/A9/A10 Log Amplifiers, Schematic Diagram	
Figure 8-35. A12 Power Supply and Component Illustrations (1 of 2) .....	8-165
Figure 8-35. A12 Power Supply and Component Illustrations (2 of 2) .....	8-166
A12 Power Supply, Schematic Diagram	
Figure 8-37. A11 Component Locations Diagram .....	8-176
Figure 8-38. A13 Component Locations Diagram .....	8-178
A13 Rear Panel, Schematic Diagram	

Figure 8–40.	16 Step Gray Scale .....	8–189
Figure 8–41.	Display Cycle .....	8–190
Figure 8–42.	VRAM Loop .....	8–192
Figure 8–43.	DRAM Cycle Test .....	8–196
Figure 8–44.	DRAM Walking 1 Pattern .....	8–197
Figure 8–45.	Repeating Gray Scale .....	8–201
Figure 8–46.	A14 Component Locations Diagram .....	8–208
A14 Display Interface, Schematic Diagram		
Figure 8–48.	Display Shield and CRT (Top View) .....	8–216
Figure 8–49.	Typical RGB Video Output .....	8–219
Figure 8–50.	A16 Component Locations Diagram .....	8–220
A16 RGB Interface, Schematic Diagram		
Figure 8–52.	8757D Simplified Block Diagram .....	8–223
Figure 8–53.	8757D Overall Troubleshooting Block Diagram .....	8–223
Figure 8–54.	A1 Front Panel, Schematic Diagram (1 of 2) .....	8–223
Figure 8–54.	A2 Front Panel Interface, Schematic Diagram (2 of 2) .....	8–223
Figure 8–55.	A3 Central Processing Unit (CPU), Schematic Diagram .....	8–223
Figure 8–56.	A4 Analog to Digital Converter (ADC), Schematic Diagram (1 of 2) .....	8–223
Figure 8–56.	A4 Analog to Digital Converter (ADC), Schematic Diagram (2 of 2) .....	8–223
Figure 8–57.	A5 Modulator Driver, Schematic Diagram .....	8–223
Figure 8–58.	A6 HP–IB, Schematic Diagram .....	8–223
Figure 8–59.	A7/A8/A9/A10 Log Amplifiers, Schematic Diagram .....	8–223
Figure 8–60.	A12 Power Supply, Schematic Diagram .....	8–223
Figure 8–61.	A13 Rear Panel, Schematic Diagram .....	8–223
Figure 8–62.	A14 Display Interface, Schematic Diagram (1 of 2) .....	8–223
Figure 8–62.	A14 Display Interface, Schematic Diagram (2 of 2) .....	8–223



## Chapter 4. Performance Tests

---

### CONTENTS

- 4-1 Introduction
- 4-1 Equipment Required
- 4-1 Performance Test Record Card
- 4-3 Self-Test
- 4-4 Dynamic Power Accuracy
- 4-5 Modulator Drive
- 4-5 Voltage Amplitude
- 4-6 Frequency Accuracy and Symmetry
- 4-7 HP INTERFACE BUS and 8757 INTERFACE
- 4-9 Performance Tests (Option 002 only)

### INTRODUCTION

These procedures test the electrical performance of the HP 8757D Scalar Network Analyzer to the specifications listed in Table 1-1 of the operating manual. Access to the interior of the instrument is not required. The performance tests must be performed in the order given. If a simpler functional operation test is desired, use the "Operator's Check" in the *Operating Reference*.

Instrument dynamic accuracy measurement results depend on calibration constants stored within the instrument using the HP 11613A/B calibrator. The HP 11613A/B, used with an HP 9000 series 200 or 300 computer and HP BASIC language, calibrates the log amplifiers independently of any detectors by injecting a 27.778 kHz square wave modulated signal at different power levels. The HP 11613A/B is supplied with a calibration program stored on a 3.5 inch disk and a 5.25 inch disk. For instructions on performing the calibration constant loading procedure, refer to the *HP 11613A/B Operating and Service Manual*.

All option 002 measurements also depend on data stored within the instrument. This data is determined by a separate program also written for a series 200/300 computer with BASIC. The part number for this software is 08757-10002. It also requires the use of an HP 8902A option 050 measurement receiver. Absolute 0dBm reference level is set using an HP 432A power meter and an HP 478A option H76 power sensor.

### EQUIPMENT REQUIRED

Equipment required for the performance tests is listed in Table 4-1. Any equipment that satisfies the critical specifications given may be substituted for the recommended models.

### PERFORMANCE TEST RECORD CARD

A performance test record card is provided at the end of this chapter for recording results of the performance tests. The specifications are listed along with space for recording actual measurements.

**Table 4–1. Recommended Test Equipment**

Instrument	Critical Specifications	Recommended Model or HP Part Number (P/N)	Use <sup>1</sup>
Sweep Oscillator	Compatible with HP 8757	HP 8350B (serial prefix 2410 or higher) or HP 8340/41 or HP 8360 series	T
RF Plug–In (with HP 8350B)	Compatible with sweep oscillator	HP 83592B (serial prefix 2502 or higher)	T
Detector	No substitute	HP 11664A (serial prefix 25000 or higher) or HP 11664E or HP 85037A/B	T
Calibrator	No substitute	HP 11613A/B	P,A,T
Oscilloscope with 10:1 Probes	Dual channel Bandwidth: $\geq 100$ MHz	HP 1740A/HP 10041A	P,T
Universal Counter	Frequency range: $\geq 1$ MHz Frequency resolution: $\leq 1$ Hz Time interval resolution: $\leq 100$ ns	HP 5316A	P,T
Digital Voltmeter	Accuracy: $\leq 0.03\%$ Resolution: $\leq 0.1$ mV Input impedance (DC): $\geq 10$ mW	HP 3456A	A,T
Power Meter with Sensor		HP 436A/HP 437B/HP 438A/HP 8481A	T
Photometer with Probe <sup>2</sup>		Tektronix J16/J6503	A
Adapter BNC Tee (m)(f)(f) (2 required)		HP P/N 1250–0781	P
Termination 50 ohm		HP 11593A	P
HP–IB Cable		HP 10833	P
BNC Cables (3 required)		HP P/N 8120–1839	P
Signature Multimeter	Signature analyzer clock frequency: $\geq 10$ MHz	HP 5005A/B	T
Service Kit	No substitute	HP P/N 08757–60048	T
Measuring Receiver <sup>3</sup>	No substitute	HP 8902A Option 050	P,A
Power Meter <sup>3</sup>	No substitute	HP 432A	P,A
Power Sensor <sup>3</sup>	No substitute	HP 478A Option H76	P,A
Computer	No substitute	HP 9000 Series 200/300 with Basic 5.0 or greater	P,A
Option 002 Calibration Software	No substitute	HP P/N 08757–10002	P,A
20 dB Attenuator		HP 8491A/B Option 020	P,A

1. P=Performance Tests, A=Adjustments, T=Troubleshooting

2. Optional, does not affect instrument performance.

3. Needed for option 002 only.



# Chapter 6. Replaceable Parts

---

## INTRODUCTION

This section contains parts ordering information. Reference designators and abbreviations are defined and a list of manufacturers is provided. Replaceable parts are listed in reference designator order, by assembly, and illustrations are provided to help with parts identification.

## PARTS LIST ORGANIZATION

Replaceable parts is organized as follows:

1. Electrical assemblies and their components in alpha–numerical order by reference designation.
2. Options.
3. Miscellaneous parts and literature part numbers.

The parts lists provide the following information:

- Reference Designation —The component or assembly is identified with this code on the schematics in this manual. The alphabetic code used in the reference designation is defined in Table 6–2.
- The HP Part Number —Use this number to order the replacement part from Hewlett–Packard.
- Qty —The total quantity of the part in the assembly. The quantity for each part is given once —at the first appearance of the part in the list.
- Description —The description of the replacement part. The abbreviations used in the descriptions are defined in Table 6–2.
- Mfr Code —The five digit code of the primary manufacturer of the part. See Table 6–2 for the list of manufacturers corresponding to the codes.
- Mfr Part Number —The primary manufacturer’s part number for the part.

## ORDERING INFORMATION

To order a part listed in the replaceable parts list, quote the Hewlett–Packard part number, indicate the quantity required, and address the order to the nearest Hewlett–Packard office.

To order a part that is not listed in the replaceable parts lists, include the instrument model number, serial number, the description and function of the part, and the quantity required. Address the order to the nearest Hewlett–Packard office.

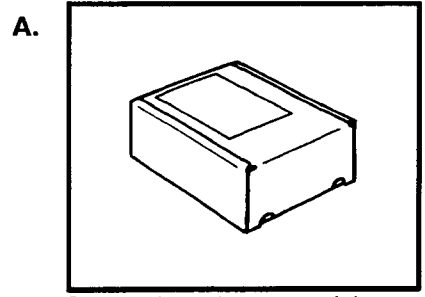
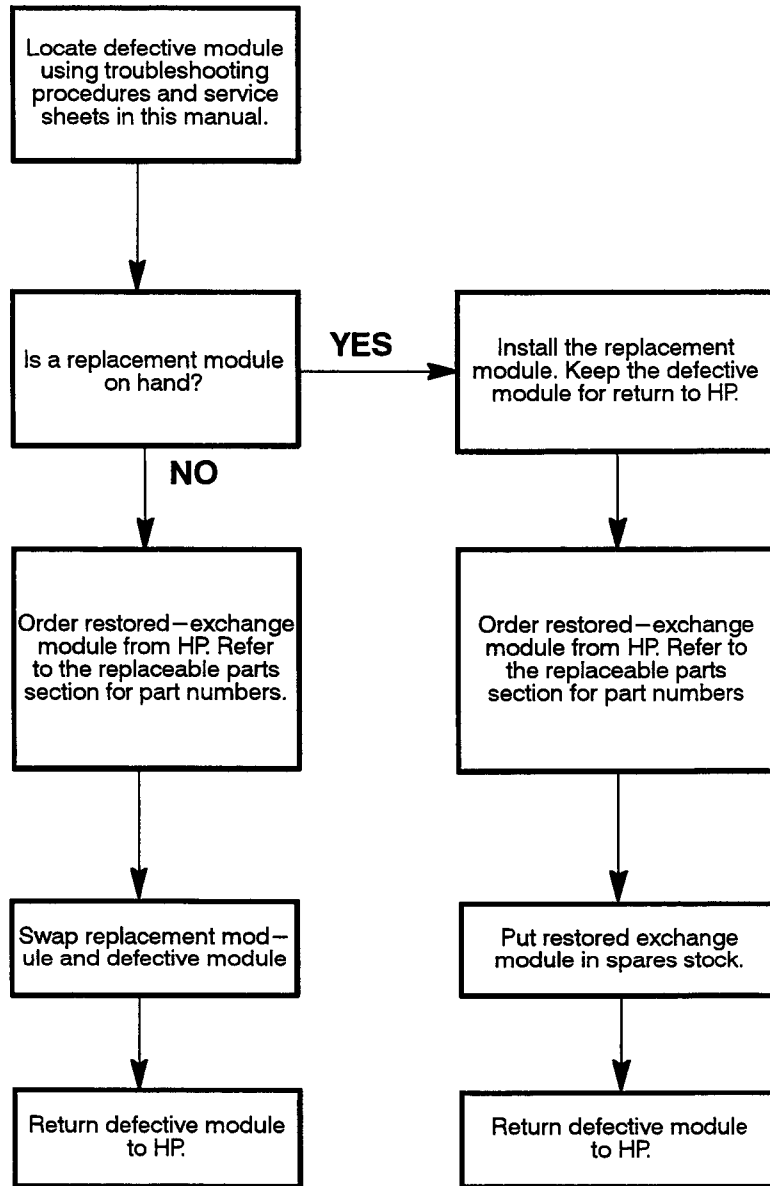
## RESTORED EXCHANGE ASSEMBLIES

Some replacement parts are available as either new or restored assemblies. The Module Exchange Program (Figure 6–1) describes the process for exchanging a defective assembly with a restored assembly. The restored assembly is more economical than a new assembly and, as with new assemblies, a 90–day warranty applies through the instrument’s support life. The defective assembly must be returned for credit (after you receive the replacement). For this reason, new assemblies must be ordered for spare parts. The part numbers for both new and restored assemblies are given in Table 6–1.

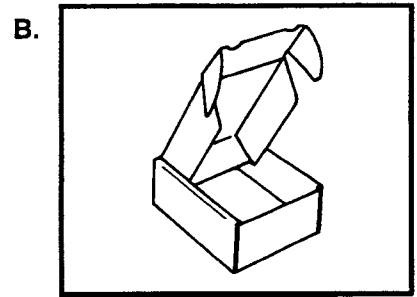
*Table 6–1. Restored Exchange Assemblies*

Reference Designator	New Part Number	Restored Exchange Part Number	Description
A7, A8, A9, A10	08757–60058	08757–69058	Log Amplifier
A14	08757–60065	08757–69065	Display Interface
A15	2090–0210	5180–8484	Display
A5 (Opt. 002 only)	08757–60111	08757–69111	Mod/Cal Opt. 002

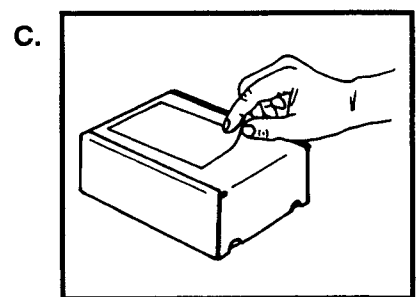
**The module exchange program is a fast, efficient and economical method of keeping your Hewlett-Packard instrument in service.**



Restored-exchange modules are shipped individually in boxes like this. In addition to the circuit module, the box contains:  
Exchange assembly failure report  
Return address label



Open box carefully - it will be used to return defective module to HP. Complete failure report. Place it and defective module in box. Be sure to remove enclosed return address label.



Seal box with tape, Inside U.S.A.\*, stick preprinted return address label over label already on box, and return box to HP. Outside U.S.A., do not use address label; instead address box to the nearest HP office.

\*HP pays postage on boxes mailed in the U.S.A.

*Figure 6-1. Module Exchange Program*

Table 6-2. Reference Designations, Abbreviations, and Manufacturer's Code List (1 of 3)

REFERENCE DESIGNATIONS

A ..... Assembly  
 AT ..... Attenuator, Isolator,  
 Limiter, Termination  
 B ..... Fan, Motor  
 C ..... Capacitor  
 CP ..... Coupler  
 CR ..... Diode, Diode Thyristor,  
 Step Recovery Diode (SCR), Varactor  
 DC ..... Directional Coupler  
 DS ..... Annunciator, Lamp, Light  
 Emitting Diode (LED), Signaling  
 Device (Audible or Visible)  
 E ..... Miscellaneous Electrical Part  
 F ..... Fuse

FL ..... Filter  
 H ..... Hardware  
 J ..... Electrical Connector  
 (Stationary Portion), Jack  
 K ..... Relay  
 L ..... Coil, Inductor  
 M ..... Meter  
 MP ..... Miscellaneous  
 Mechanical Part  
 P ..... Electrical Connector  
 (Movable Portion), Plug  
 Q ..... Silicon Controlled Rectifier  
 (SCR), Transistor, Triode Thyristor  
 R ..... Resistor

RT ..... Thermistor  
 S ..... Switch  
 T ..... Transformer  
 TB ..... Terminal Board  
 TP ..... Test Point  
 U ..... Integrated Circuit, Microcircuit  
 V ..... Electron Tube  
 VR ..... Breakdown Diode  
 (Zener), Voltage Regulator  
 W ..... Cable, Transmission Path, Wire  
 X ..... Socket  
 Y ..... Crystal Unit  
 (Piezoelectric, Quartz)  
 Z ..... Tuned Cavity, Tuned Circuit

ABBREVIATIONS

A

A ..... Across Flats, Acrylic,  
 Air (Dry Method), Ampere  
 ADJ ..... Adjust, Adjustment  
 AL ..... Aluminum  
 AMP ..... Amperage  
 ALC ..... Alcohol,  
 Automatic Level Control  
 AMP ..... Amperage  
 AMPL ..... Amplifier  
 ANDZ ..... Anodized  
 ANLG ..... Analog  
 ASSY ..... Assembly  
 ASTBL ..... Astable  
 ATTEN ..... Attenuation, Attenuator  
 AWG ..... American Wire Gauge

B

BCKT ..... Bracket  
 BD ..... Board, Bundle  
 BE ..... Baume, Beryllium  
 BFR ..... Before, Buffer  
 BLK ..... Black, Blank, Block  
 BNC ..... Type of Connector  
 BSC ..... Basic  
 BVR ..... Reverse, Breakdown Voltage

C

C ..... Capacitance, Capacitor,  
 Center Tapped, Centistoke,  
 CeramicCermet,  
 Circular Mil Foot, Closed  
 Cup, Cold, Compression  
 CBL ..... Cable  
 CER ..... Ceramic  
 CHAM ..... Chamfer  
 CHAN ..... Channel  
 COAX ..... Coaxial  
 COM ..... Commercial, Common  
 CONN ..... Connect, Connection,  
 Connector  
 CONT ..... Contact, Continuous,  
 Control, Controller  
 CONV ..... Cadmium Plate,  
 Candle Power, Centipoise,  
 Conductive Plastic, Cone Point

CRP ..... Crepe, Crimp  
 CTR ..... Center  
 CURRNT ..... Current

D

D ..... Deep, Depletion, Depth,  
 Diameter, Direct Current  
 D/A ..... Digital-to-Analog  
 DB ..... Decibel, Double Break  
 DAP ..... Diallyl Phthalate  
 DC ..... Direct Current, Double Contact  
 DBL ..... Double  
 DEG ..... Degree  
 DIA ..... Diameter  
 DIFF ..... Differential  
 DIP ..... Dual In-Line Package  
 DO ..... Package Type Designation  
 DRVR ..... Driver

E

E ..... Enamel (Insulation,  
 Enhancement, Extension)  
 E-MODE ..... Enhancement Mode  
 EPROM ..... Erasable  
 Programmable Read Only Memory  
 EXCL ..... Excluding, Exclusive  
 EXT ..... Extended, Extension,  
 External, Extinguish

F

F ..... Fahrenheit, Farad, Female,  
 Film, (Resistor), Fixed,  
 Flange, Flint, Flourine, Frequency  
 FDTHRU ..... Feed Through  
 FEM ..... Female  
 FF ..... Flange, Female  
 Connection, Flip Flop  
 FL ..... Flash, Flat, Fluid  
 FLEX ..... Flexible  
 FLG ..... Flange  
 FLTR ..... Filter, Floater  
 FT ..... Feet

FM ..... Flange, Male Connection;  
 Foam, Frequency Modulation  
 Product (Transition Frequency);  
 Feet, Foot  
 FXD ..... Fixed

G

GEN ..... General, Generator  
 GHZ ..... Gigahertz  
 GP ..... General Purpose Group  
 GL ..... Glass  
 GRN ..... Green  
 GRV ..... Grooved

H

H ..... Henry, Hermaphrodite, High  
 Hole Diameter, Hot, Hub  
 Inside Diameter, Hydrogen  
 HD ..... Hand, Hard, Head,  
 Heavy Duty  
 HEX ..... Hexadecimal, Hexagon,  
 Hexagonal  
 HGT ..... Height

I

IC ..... Collector Current,  
 Integrated Circuit  
 ID ..... Identification, Inside  
 Diameter  
 IF ..... Intermediate Frequency  
 IMPD ..... Impedance  
 IN ..... Inch, Indium  
 INP ..... Input  
 INS ..... Insert, Inside, Insulation,  
 Insulator  
 INT ..... Integral, Intensity, Internal  
 INTL ..... Internal, International  
 INV ..... Invert, Inverter

J

JFET ..... Effect Transistor

K

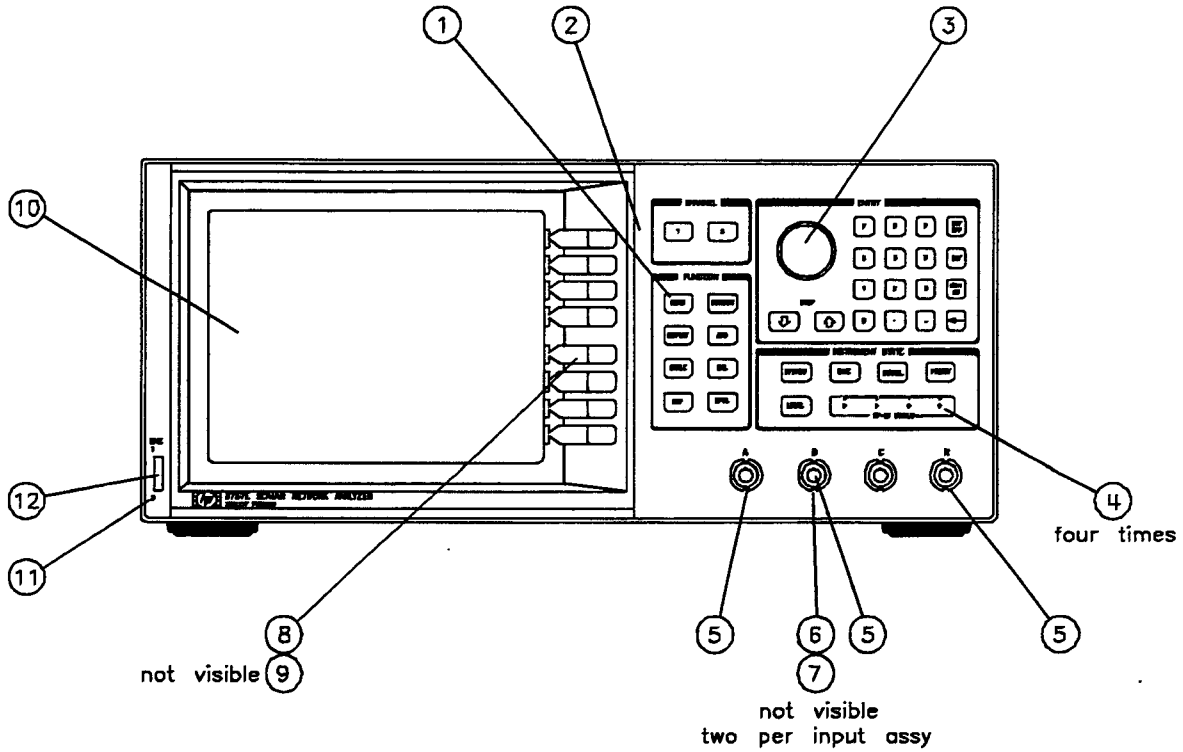
K ..... Kelvin, Key, Kilo, Potassium  
 KB ..... Knob

**Table 6-2. Reference Designations, Abbreviations, and Manufacturer's Code (2 of 3)**

<b>L</b>	PC..... Printed Circuit	SM..... Samarium, Seam, Small, Square Meter, Sub Modular Subminiature
LED..... Light Emitting Diode	PCB..... Printed Circuit Board	SMB..... Subminiature, B Type (Snap-On Connector)
LG..... Length, Long	PD..... Pad, Palladium, Pitch Diameter, Power Dissipation	SNP..... Snap
LIN..... Linear, Linear Taper, Linearity	PF..... Picofarad; Pipe, Female Connection; Power Factor	SPCL..... Special
LK..... Link, Lock	PKG..... Package	SQ..... Square
LKG..... Leakage, Locking	PL..... Phase Lock, Plain, Plate, Plug	SST..... Stainless Steel
LKWR..... Lockwasher	PL-MTG..... Plate Mounting	STDF..... Standoff
<b>M</b>	PLSTC..... Plastic	SZ..... Size
M..... Male, Maximum, Mega, Mil, Milli, Mode, Momentary, Mounting Hole Centers, Mounting Hole Diameter	PN..... Part Number	<b>T</b>
MA..... Milliampere	PNP..... Positive Negative Positive (Transistor)	T..... Tab Width, Taper, Teeth, Temperature, Tera, Tesla Thermoplastic (Insulation) Thickness, Time, Timed, Tooth, Turns Ratio, Typical
MACH..... Machined	POLYC..... Polycarbonate	TA.. Ambient Temperature, Tantalum
MAX..... Maximum	POLYE..... Polyester	TC..... Thermoplastic
MCD..... Millicandela	POS..... Position, Positive	TFE.. Polytetrafluoro-ethylene, Teflon
MICPROC..... Microprocessor	POZI..... Pozidrive Recess	THD..... Thread, Threaded
MIN..... Miniature, Minimum, Minor, Minute	PRCN..... Precision	THK..... Thick
MLD..... Mold, Molded	PRL..... Parallel	TO..... Package Type
MM..... Magnetized Material, (Restricted Articles Code) Millimeter	PRIM..... Primary	TPL..... Triple
MO..... Metal Oxide Milliounce, Molybdenum	PRP..... Purple, Purpose	TRIG..... Trigger, Triggerable, Triggering, Trigonometry
MOD..... Model, Modified Modular, Modulated, Modulator	P/S..... Power Supply	TRMR..... Trimmer
MOM..... Momentary, Motherboard	PT..... Part, Pint, Platinum, Point, Pulse Time	TRN..... Turn, Turns
MTG..... Mounting	PVC..... Polyvinyl Chloride	TTL..... Tan Translucent, Transistor, Transistor Logic
MTR..... Meter	PW . Power Wirewound, Pulse Width	<b>U</b>
MULTIPLXR..... Multiplexer	<b>Q</b>	UCD..... Microcandela
MUW..... Musice Wire	QUAD..... Set of Four	UNCT..... Undercut
MW..... Milliwatt	<b>R</b>	UF..... Microfarad
<b>N</b>	RBN..... Ribbon	<b>V</b>
N-CHAN..... N-Channel Metal Oxide Semiconductor	RCVR..... Receiver	V..... Vanadium, Variable, Violet, Volt, Voltage
NB..... Niobium	RECT..... Rectangle, Rectangular, Rectifier	VA..... Volt Ampere
NCH..... Notched	RES..... Research, Resistance, Resistor, Resolution	VDC..... Volts, Direct Current
NEG..... Negative	RET..... Retaining	VIC..... Video
NH..... Nanohenry	RF..... Radio Frequency	<b>W</b>
NM..... Nanometer, Nonmetallic	RFI... Radio Frequency Interference	W..... Watt, Wattage, White, WB..... Wide Band Wide, Width, Wire
NO..... Normally Open, Number	RFLTR..... Regulator	WD..... Width, Wood
NPN..... Negative Positive Negative (Transistor)	RKR..... Rocker	<b>X</b>
NS... Nanosecond, Non-Shorting, Nose	RND..... Round	XSTR..... Transistor
NYL..... Nylon (Polyamide)	RPG..... Rotary Pulse Generator	<b>Y</b>
<b>O</b>	RR..... Rear	YIG..... Yttrium-iron-garnet
OCTL..... Octal	RVT..... Rivet, Riveted	YTM..... YIG Tuned Multiplier
OD... Olive Drab, Outside Diameter	<b>S</b>	<b>Z</b>
OP..... Operational	SCR..... Screw, Scrub, Silicon Controlled Rectifier	ZN-P..... Zener
OPT..... Optical, Option, Optional	SEC..... Secondary	ZNR..... Zener
OXD..... Oxide	SER..... Serial, Series	
<b>P</b>	SGL..... Single	
PAN-HD..... Pan Head	SHFT..... Shaft	
PC..... Picocoulomb, Piece, Printed Circuit	SHLDR..... Shoulder	
	SI..... Silicon, Square Inch	
	SIG..... Signal, Significant	
	SIP..... Single In-Line Package	
	SKT..... Skirt, Socket	
	SLDR..... Solder	

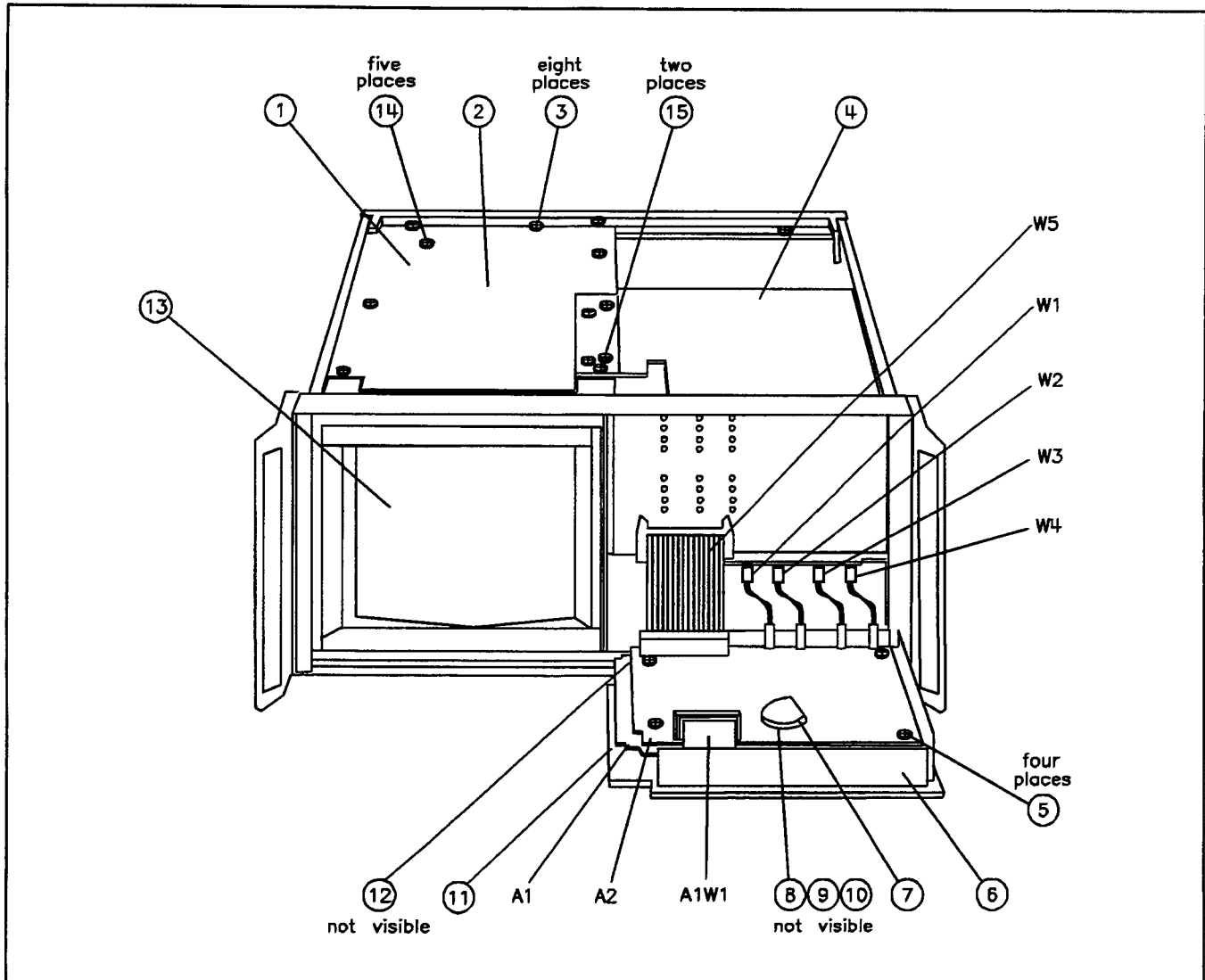
**Table 6-2. Reference Designations, Abbreviations, and Manufacturer's Code (3 of 3)**

00039	NEC ELECTRONICS INC	MTN VIEW, CA	94043
00046	UNITRODE CORP	LEXINGTON, MA	02173
01074	MEGGITT-ELECTRONIC COMPONENTS LTD	SWINDON, WILTSHI	
01380	AMP INC	HARRISBURG, PA	17111
01417	NEL FREQUENCY CONTROLS INC	BURLINGTON, WI	53105
01607	ALLEN-BRADLEY CO INC	EL PASO, TX	79935
01698	TEXAS INSTRUMENTS INC	DALLAS, TX	75265
01924	ITW FASTEX	DES PLAINES, IL	60016
02010	AVX CORP	GREAT NECK, NY	11021
02037	MOTOROLA INC	ROSELLE, IL	60195
02121	LYN-TRON INC	BURBANK, CA	91505
02180	PRECISION MONOLITHICS INC	SANTA CLARA, CA	95054
02414	BURNDY CORP	NORWALK, CT	06856
02483	CTS CORP	ELKHART, IN	46514
02499	IRC INC	BOONE, NC	28607
02688	MICROSEMI CORP	SCOTSDALE, AZ	85252
02883	SILICONIX INC	SANTA CLARA, CA	95054
02910	SIGNETICS CORP	SUNNYVALE, CA	94086
02946	DUPONT E I DE NEMOURS & CO	WILMINGTON, DE	19801
03038	INTL RECTIFIER CORP	LOS ANGELES, CA	90069
03171	SOLITRON DEVICES INC	PALM BEACH, FL	33404
03273	GOWANDA ELECTRONICS CORP	GOWANDA, NY	14070
03285	ANALOG DEVICES INC	NORWOOD, MA	02062
03316	SPECIALTY CONNECTOR CO	FRANKLIN, IN	46131
03394	METHODE ELECTRONICS INC	CHICAGO, IL	60656
03406	NATIONAL SEMICONDUCTOR CORP	SANTA CLARA, CA	95052
03418	MOLEX INC	LISLE, IL	60532
03744	BOURNS NETWORKS INC	RIVERSIDE, CA	92507
03799	HARRIS CORP	MELBOURNE, FL	32901
03811	INTEL CORP	SANTA CLARA, CA	95054
03981	PENN ENGINEERING & MFG CORP	DOYLESTOWN, PA	18901
04055	OVERLAND PRODUCTS CO	PHOENIX, AZ	85025
04200	SPRAGUE ELECTRIC CO	LEXINGTON, MA	02173
04504	GENERAL INSTRUMENT CORP	CLIFTON, NJ	07012
04559	ELASTIC STOP NUT DIV OF HARVARD	UNION, NJ	07083
04568	BECKMAN INDUSTRIAL CORP	FULLERTON, CA	92635
04703	LITTELFUSE INC	DES PLAINES, IL	60016
04726	3M CO	ST PAUL, MN	55144
04990	GRAYHILL INC	LA GRANGE, IL	60525
05176	AMERICAN SHIZUKI CORP	CANOGA PARK, CA	91304
05313	SEASTROM MFG CO	GLENDALE, CA	91201
05436	BURR-BROWN CORP	TUCSON, AZ	85706
05447	BERGQUIST CO	MINNEAPOLIS, MN	55420
05466	EMHART CORP	FARMINGTON, CT	06032
05518	AUGAT INC	MANSFIELD, MA	02048
05524	DALE ELECTRONICS INC	COLUMBUS, NE	68601
05879	AMPHENOL CORPORATION	DANBURY, CT	06810
06118	ROEDERSTEIN/RESISTA GMBH	LANDSHUT	8300
06121	SIEMENS AG	MUNICH	8000
06337	PHILIPS ELECTRONICS N V	EINDHOVEN	
06347	HITACHI LTD	CHIYODA-KU - TO	101
06691	HOUSE OF METRICS LTD	SPRING VALLEY, NY	10977
08779	MITSUBISHI ELECTRONICS AMERICA	SUNNYVALE, CA	94086
08781	CATALYST RESEARCH CORP	OWINGS MILLS, MD	21117
09538	TUSONIX	TUCSON, AZ	85740
09694	ELECTRONIC ESSENTIALS	WOODSIDE, NY	
09939	MURATA ERIE NORTH AMERICA INC	SMYRNA, GA	30080
10421	EPSON AMERICA INC	TORRENCE, CA	90509
10456	PLASTEC PRODUCTS INC	FORT COLLINS, CO	
10572	XICOR, INC	MILPITAS, CA	
10858	LINEAR TECHNOLOGY CORP	MILPITAS, CA	95035
11170	PHOENIX TERMINAL BLOCKS INC	BLOMBERG	
11212	INDUCTOR SUPPLY, INC.	HUNTINGTON BCH, CA	
12186	DALLAS SEMICONDUCTOR CORP	DALLAS, TX	75244



Reference Designation	HP Part Number	Qty	Description	Mfr Code	Mfr Part Number
1	08757-40016		KEYPAD - RUBBER	28480	08757-40016
2	08757-80084	1	FRONT PANEL OVERLAY (STANDARD)	28480	08757-80084
	08757-80085		FRONT PANEL OVERLAY OPTION 001	28480	08757-80085
	08757-80086		FRONT PANEL OVERLAY OPTION 002	28480	08757-80086
	08757-80083		FRONT PANEL OVERLAY OPTION 001/002	28480	08757-80083
3	01650-47401	1	KNOB-BASE 1 1/8 JGK	28480	01650-47401
4	1990-0858	4	LED-LAMP LUM-INT=15UCD IF=25MA-MAX	28480	1990-0858
5	08757-60034	3	P/O DETECTOR INTFC ASSY	28480	08757-60034
6	2190-0584	6	WASHER-LK HLCL 3.0MM 3.1-MM-ID	28480	2190-0584
7	0535-0004	6	NUT-HEX DBL-CHAM M3 X 0.5 2.4MM-THK	00000	ORDER BY DESC.
8	08757-40012	1	BUTTON COVER	28480	08757-40012
9	0515-0898	2	SCREW-MACH M4 X 0.7 6MM-LG PAN-HD	00000	ORDER BY DESC.
10	5062-7208	1	BEZEL WITH GLASS FILTER	28480	5062-7208
11	08757-40003	1	BEZEL SUPPORT	28480	08757-40003
12	08757-40005	1	LINE BUTTON	28480	08757-40005

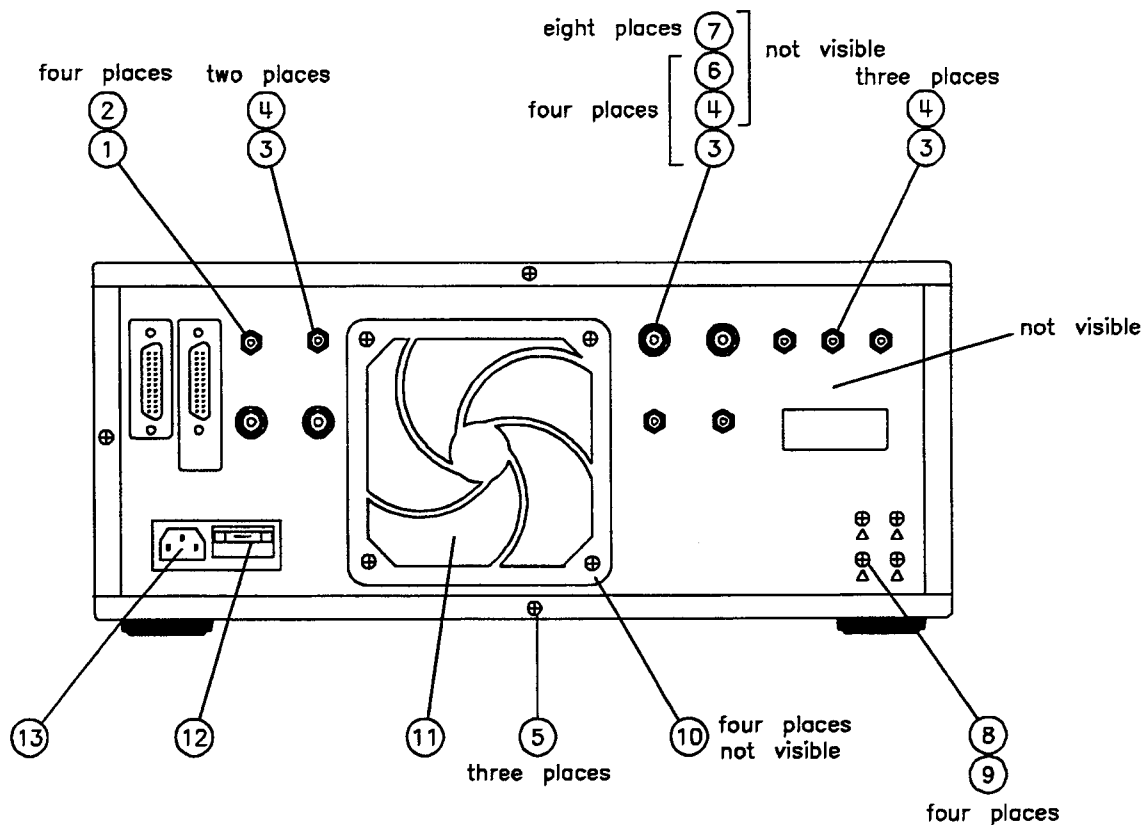
Figure 6-2. Front View (1 of 9)



Reference Designation	HP Part Number	Qty	Description	Mfr Code	Mfr Part Number
1	08757-00053	1	CRT SHIELD	28480	08757-00053
2	7120-4293	1	WARNING LABEL	28480	7120-4293
3	0515-0885	8	SCREW-MACH M4 X 0.7 8MM-LG PAN-HD	00000	ORDER BY DESC.
4	08757-00056	1	LOGGER COVER	28480	08757-00056
5	0515-1112	4	SCREW-MACH M3 X 0.5 20MM-LG PAN-HD	00000	ORDER BY DESC.
6	08757-00062	1	FRONT SUBPANEL	28480	08757-00062
7	1990-1525	1	RPG ASSEMBLY	28480	1990-1525
8	2190-0016	1	WASHER-LK INTL T 3/8 IN .377-IN-ID	28480	2190-0016
9	2950-0001	1	NUT-HEX-DBL-CHAM 3/8-32-THD .094-IN-THK	28480	2950-0001
10	2950-0043	1	NUT-HEX-DBL-CHAM 3/8-32-THD .094-IN-THK	28480	2950-0043
11	08757-40016	1	KEYPAD -RBR	28480	08757-40016
12	0515-1105	8	SCREW-MACH M3 0.5 10MM-LG PAN-HD	00000	ORDER BY DESC.
13	08757-40010	1	DISPLAY GASKET	28480	08757-40010
14	0515-0372	5	SCREW-MACHINE ASSEMBLY M3 X 0.5 8MM-LG (NOT SHOWN)	00000	ORDER BY DESC.
15	0515-0374	2	SCREW-MACHINE ASSEMBLY M3 X 0.5 10MM-LG (NOT SHOWN)	00000	ORDER BY DESC.
A1	08757-60112	1	FRONT PANEL KEYBOARD ASSY	28480	08757-60112
A2	08757-60113	1	FRONT PANEL INTERFACE	28480	08757-60113
A1W1	08757-60045	1	FRONT PANEL KEYBOARD/INTERFACE CABLE	28480	08757-60045
W1-W4	08757-60034	1	FRONT PANEL DETECTOR INTERFACE ASSY	28480	08757-60034
W5	8120-4112	1	FRONT PANEL INTERFACE CABLE	28480	8120-4112

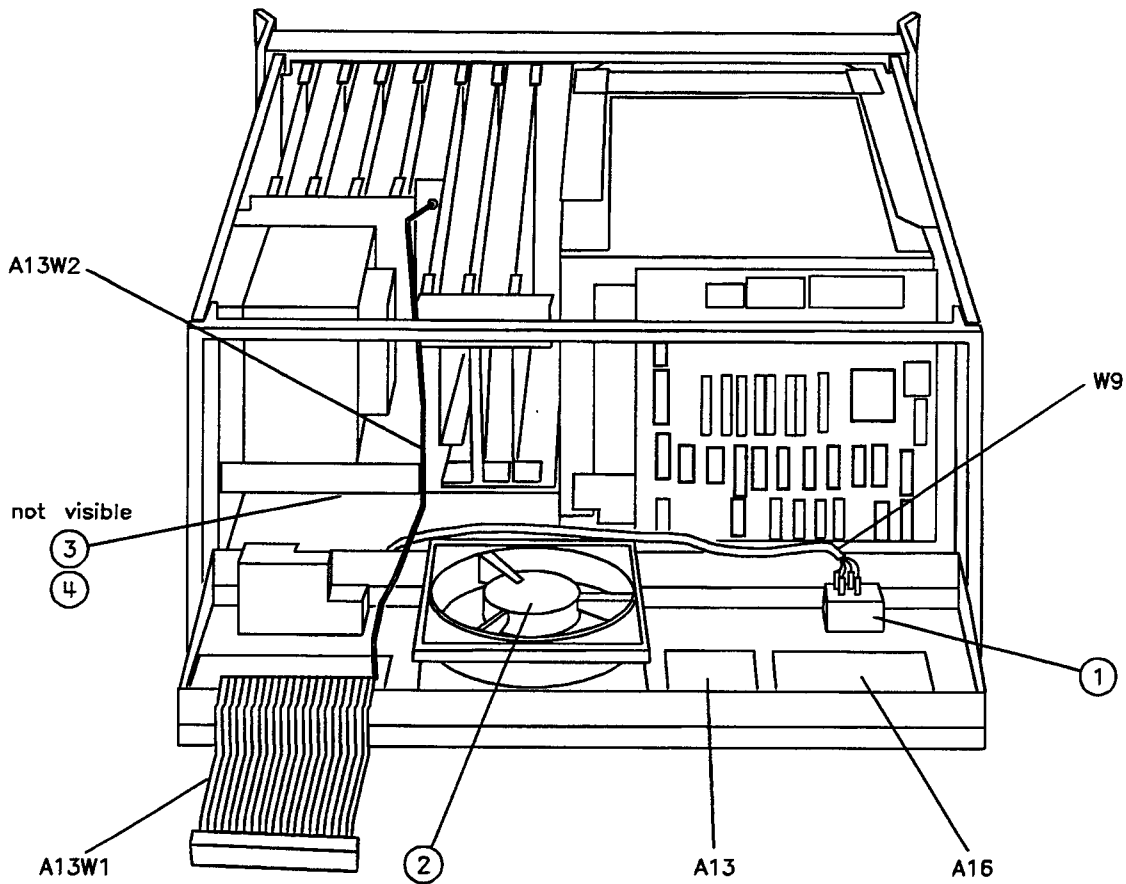
Figure 6-2. Front View Interior (2 of 9)





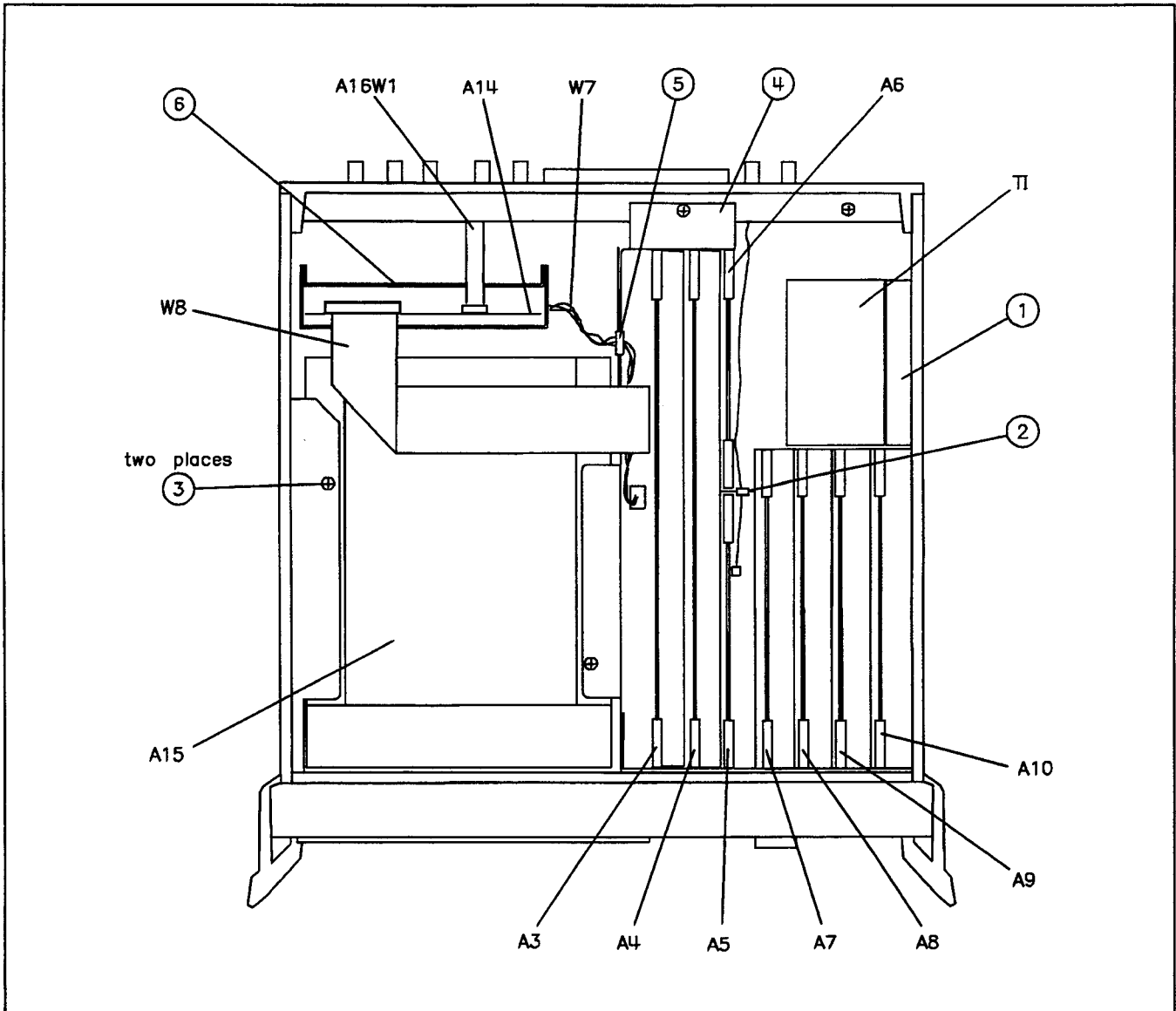
Reference Designation	HP Part Number	Qty	Description	Mfr Code	Mfr Part Number
1	0380-0643	4	STANDOFF-HEX .255-IN-LG 6-32THD	00000	ORDER BY DESC.
2	2190-0017	4	WASHER-LK HLCL NO.8 .168-IN-ID	28480	2190-0017
3	2950-0035	11	NUT-HEX-DBL-CHAM 15/32-32-THD	00000	ORDER BY DESC.
4	2190-0102	11	WASHER-LK INTL T 15/32 IN .472-IN-ID	28480	2190-0102
5	0515-1245	3	SCREW-SPCL M3.5 X 0.6 12MM-LG	00000	ORDER BY DESC.
6	3050-1094	4	WASHER-FL MTLC 1/2 IN .505-IN-ID	28480	3050-1094
7	5040-8857	8	WASHER-SHOULDER	28480	5040-8857
8	0624-0324	4	SCREW-TPG 4-20 .312-IN-LG PAN HP-POZI	00000	ORDER BY DESC.
9	3050-0891	4	WASHER-FL MTLC 3.0MM 3.3-MM-ID	28480	3050-0891
10	0515-1817	4	SCREW-MACH M3.5 X 0.6 20MM-LG	00000	ORDER BY DESC.
11	3150-0484	1	FILTER/GUARD/RETAINER-FAN	28480	3150-0484
12	2110-0083	1	FUSE (INCH) 2.5A 250V NTD FE UL	00000	ORDER BY DESC.
	2110-0043	1	FUSE (INCH) 1.5A 250V NTD FE UL	00000	ORDER BY DESC.
13	0960-0443	1	LINE MODULE-FILTERED	02085	F2058D

Figure 6-2. Rear View (3 of 9)



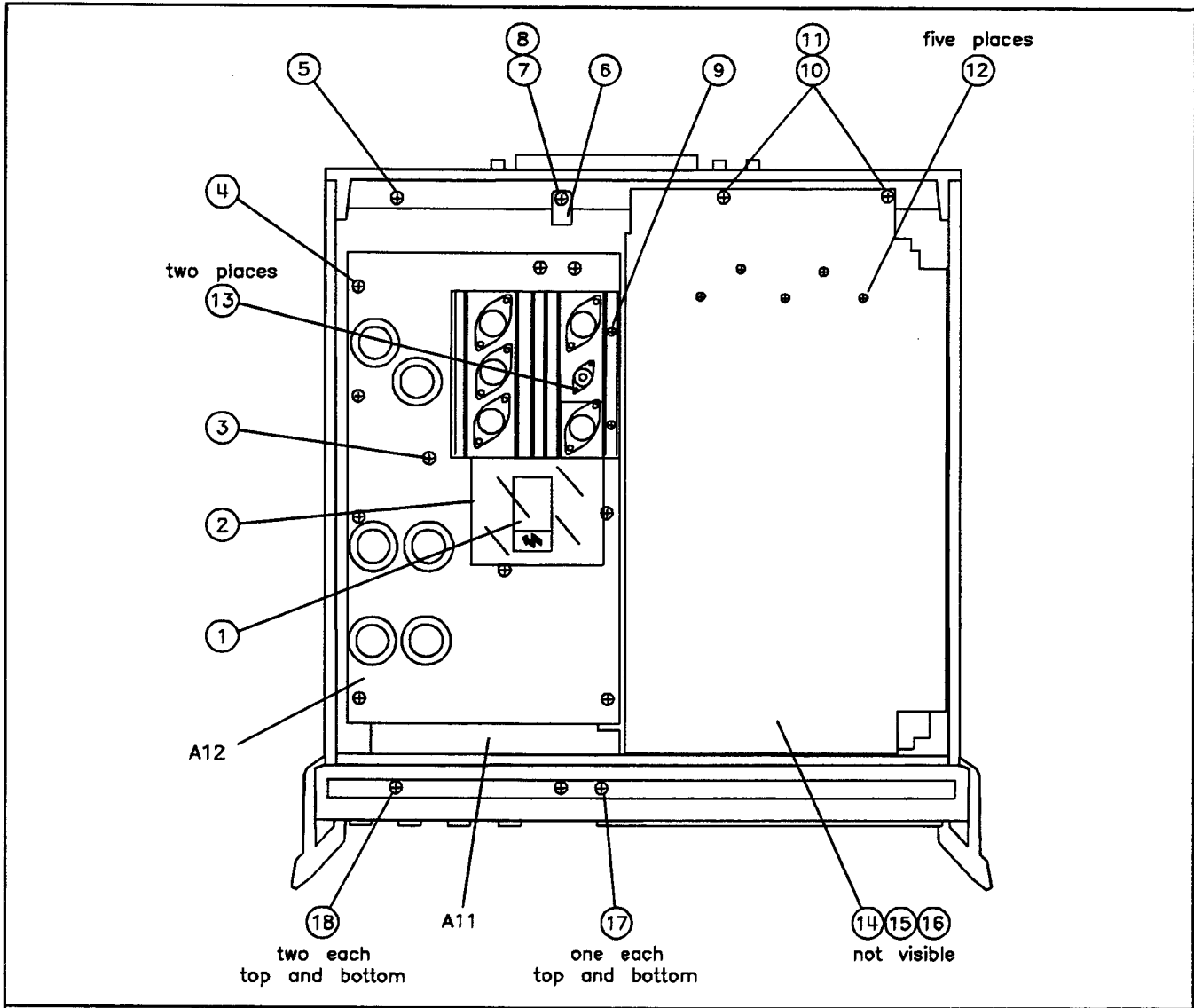
Reference Designation	HP Part Number	Qty	Description	Mfr Code	Mfr Part Number
1	3101-2780	1	SWITCH DPST (PART OF W9)	28480	3101-2780
2	08757-20083	1	FAN-MODIFIED	28480	08757-20083
3	1251-3967	1	CONTACT-CONN U/W-POST-TYPE FEM CRP	28480	1251-3967
4	1251-4933	1	CONN-POST TYPE 2.5-PIN-SPCG 3-CONT	28480	1251-4933
A13	08757-60013	1	REAR PANEL ASSEMBLY	28480	08757-60013
A13W1	08757-60029	1	REAR PANEL/MOTHERBOARD CABLE	28480	08757-60029
A13W2	08757-60044	1	REAR PANEL/ MODULATOR BOARD CABLE	28480	08757-60044
A16	08757-60077	1	RGB INTERFACE	28480	08757-60077
W9	08757-60033	1	POWER CABLE ASSEMBLY (INCLUDES SWITCH)	28480	08757-60033

Figure 6-2. Rear View Interior (4 of 9)



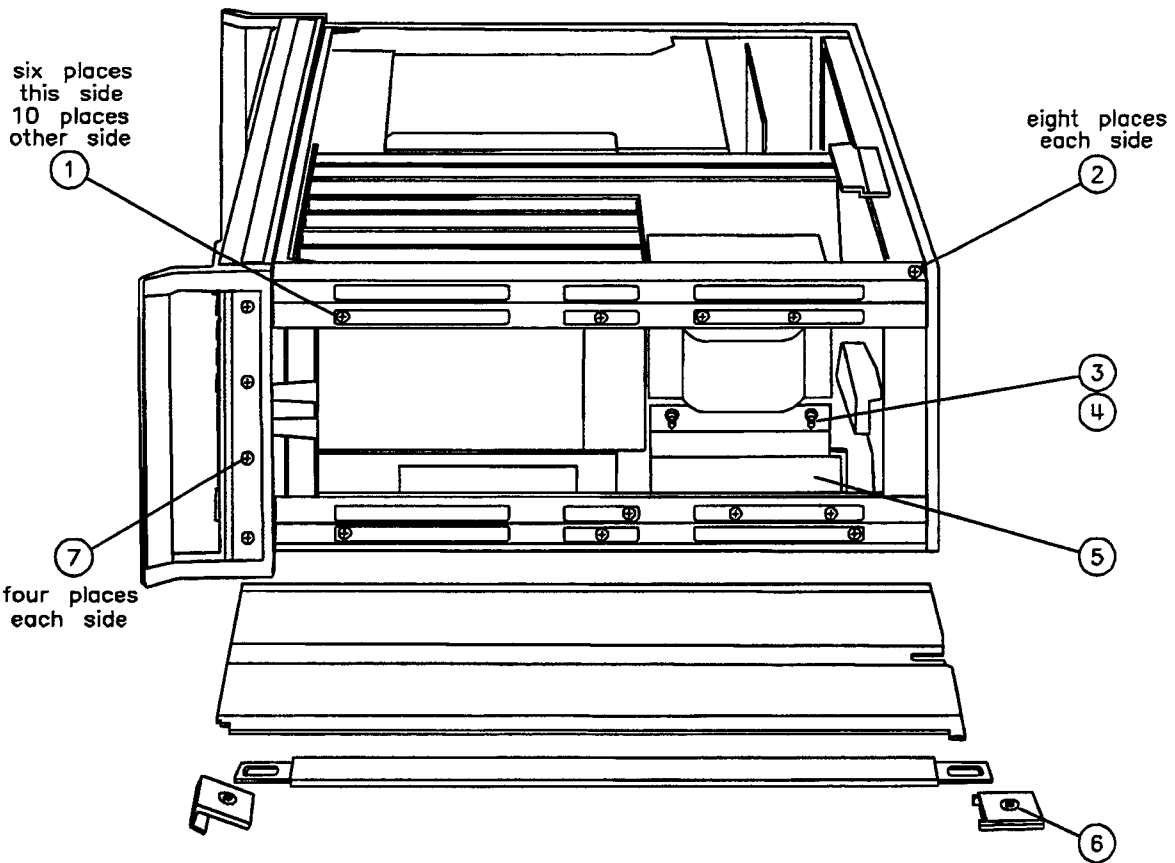
Reference Designation	HP Part Number	Qty	Description	Mfr Code	Mfr Part Number
1	08757-00045	1	TRANSFORMER MOUNTING FRAME	28480	08757-00045
2	0400-0009	1	GROMMET-RND .125-IN-ID .25-IN-GRV-OD	00000	ORDER BY DESC.
3	0515-0885	2	SCREW-MACH M4 X 0.7 8MM-LG PAN-HD	00000	ORDER BY DESC.
4	08757-00032	1	REAR SUPPORT	28480	08757-00032
5	0400-0002	1	GROMMET-RND .188-IN-ID .312-IN-GRV-OD	00000	ORDER BY DESC.
6	08757-00054	1	ENCLOSURE - GSP	28480	08757-00054
A3	08757-60115	1	CPU ASSEMBLY	28480	08757-60115
A4	08757-60004	1	ADC ASSEMBLY	28480	08757-60004
A5	08757-60005	1	MODULATOR DRIVE ASSEMBLY STANDARD	28480	08757-60005
	08757-60111	1	MODULATOR DRIVE ASSEMBLY OPTION 002	28480	08757-60111
A6	08757-60006	1	HP-IB ASSEMBLY	28480	08757-60006
A7-A10	08757-60058	4	LOG AMPLIFIER (A9 HP 8757D OPT 001 ONLY)	28480	08757-60058
A14	08757-60065	1	DISPLAY INTERFACE	28480	08757-60065
A15	2090-0210	1	DISPLAY	28480	2090-0210
A16W1	08757-60083	1	RGB INTERFACE CABLE	28480	8120-3308
T1	9100-4766	1	POWER TRANSFORMER	28480	9100-4766
W7	08757-60071	1	A14 POWER CABLE	28480	08757-60071
W8	08757-60076	1	CABLE AY-34C 28AWG	28480	08757-60076

Figure 6-2. Top View (5 of 9)



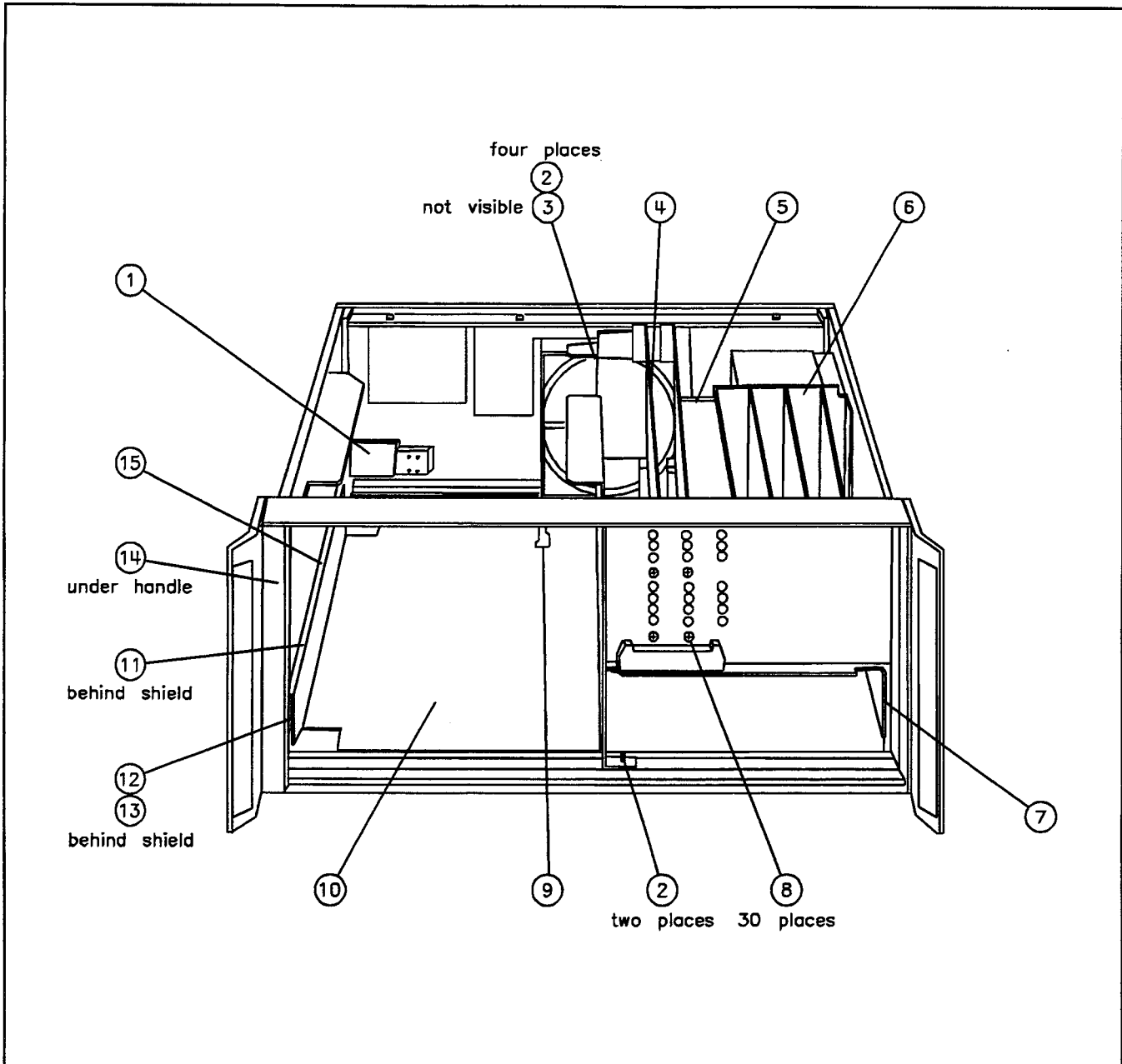
Reference Designation	HP Part Number	CD	Qty	Description	Mfr Code	Mfr Part Number
1	7120-4293	4	1	WARNING LABEL	28480	7120-4293
2	08757-20084	8	1	SHIELD	28480	08757-20084
3	0515-1111	9	2	SCREW-MACH M3 X 0.5 16MM-LG PAN HD	00000	ORDER BY DESC.
4	0515-1059	4	6	SCREW-MACH M2.5 X 0.45 28MM-LG PAN-HD	00000	ORDER BY DESC.
5	0515-0885	2	1	SCREW-MACH M4 X 0.7 8MM-LG PAN-HD	00000	ORDER BY DESC.
6	1400-0024	9	1	CLAMP-CABLE .25-DIA .5-WD NYL	00000	ORDER BY DESC.
7	0515-1368	8	1	SCREW-MACH M4 X 14 PN PD	00000	ORDER BY DESC.
8	3050-0893	9	1	WASHER-FL MTLT 4.0 MM 4.4-MM-ID	00000	ORDER BY DESC.
9	0515-1453	2	2	SCREW-MACH M4 X 14 PN PD	00000	ORDER BY DESC.
10	3050-0893	9	2	WASHER-FL MTLT 4.0 MM 4.4-MM-ID	00000	ORDER BY DESC.
11	0515-1368	8	2	SCREW-MACH M4 X 14 PN PD	00000	ORDER BY DESC.
12	0515-2032	5	5	SCREW-MACHINE M3 X 0.5 8MM-LG 90-DEG-FLH-HD	00000	ORDER BY DESC.
13	0515-1079	8	2	SCREW-MACH ASSY M3 X 0.5 8MM-LG	00000	ORDER BY DESC.
14	8160-0649	1	1	RFI CONTACT	28480	8160-0649
15	08757-00041	5	1	RFI BASE PLATE	28480	08757-00041
16	0515-0885	2	2	SCREW-MACH M4 X 0.7 8MM-LG PAN-HD	00000	ORDER BY DESC.
17	0515-0396	0	2	SCREW-MACH M4 X 0.7 10MM-LG	00000	ORDER BY DESC.
18	0515-1367	7	4	SCREW-MACH M4	00000	ORDER BY DESC.
A11	08757-60066	0	1	MOTHERBOARD	28480	08757-60066
A12	08757-60102	1	1	POWER SUPPLY BOARD	28480	08757-60102

Figure 6-2. Bottom View (6 of 9)



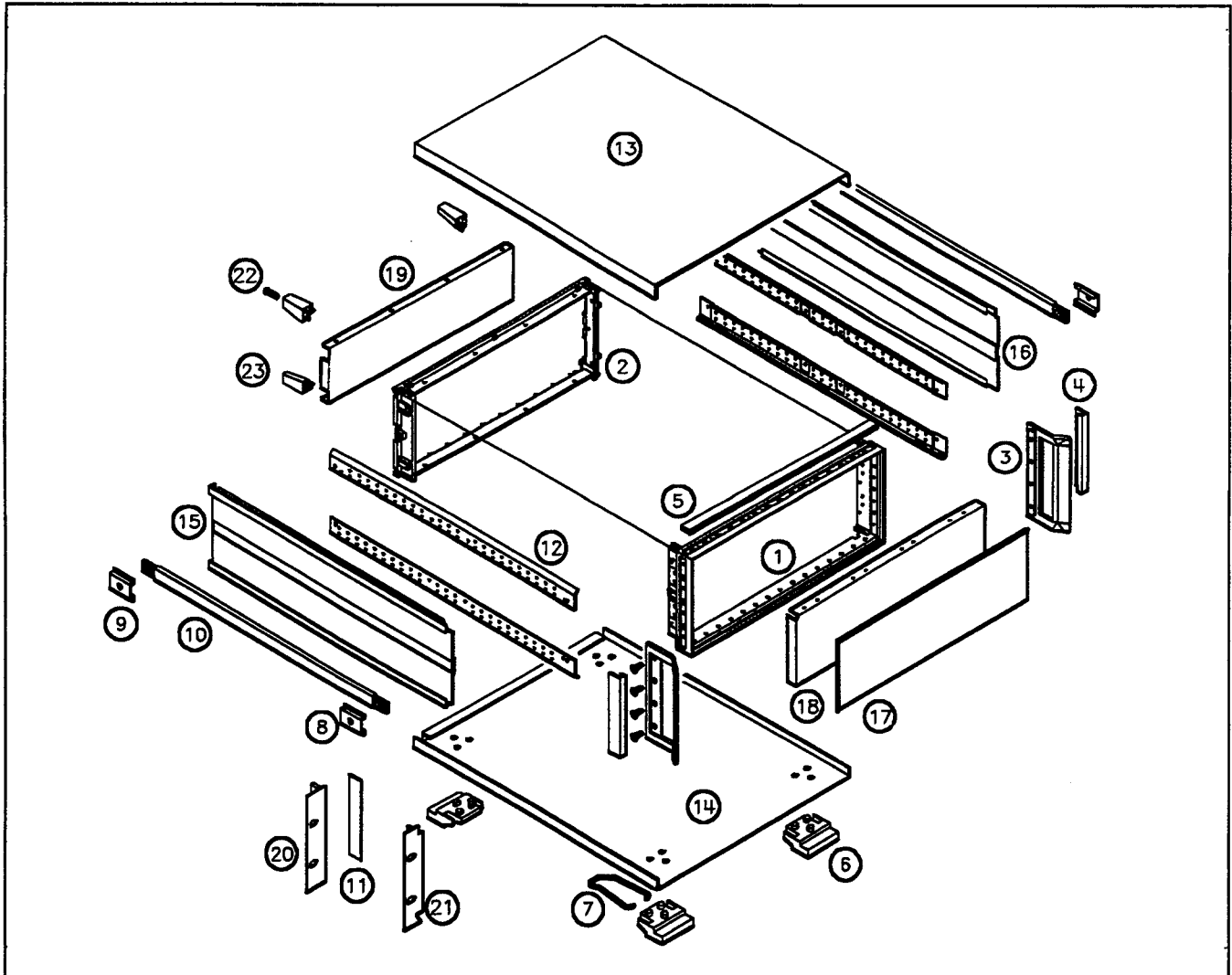
Reference Designation	HP Part Number	CD	Qty	Description	Mfr Code	Mfr Part Number
1	0515-0885	3	16	SCREW-MACH M3 X 0.5	00000	ORDER BY DESC.
2	0515-1131	3	16	SCREW-MACH M5 X 0.8 25MM-LG	00000	ORDER BY DESC.
3	0515-1145	9	2	SCREW-MACH M4 X 0.7 80MM-LG PAN-HD	00000	ORDER BY DESC.
4	3050-0152	3	4	SCREW-SKT-HD-CAP M6 X 1.0 40MM-LG	00000	ORDER BY DESC.
5	08757-00045	9	1	TRANSFORMER MOUNTING FRAME	28480	08757-00045
6	0515-1132	4	2	SCREW-MACH M5 X 0.8 10MM-LG	00000	ORDER BY DESC.
7	0515-0896	5	8	SCREW-MACH M4 X 0.7 10MM-LG	00000	ORDER BY DESC.

Figure 6-2. Side View (7 of 9)



Reference Designation	HP Part Number	CD	Qty	Description	Mfr Code	Mfr Part Number
1	08757-40009	9	1	ACTUATOR EXTENDER	28480	08757-40009
2	0515-1079	8	6	SCREW-MACH ASSY M3 X 0.5 8MM-LG	00000	ORDER BY DESC.
3	08757-20071	3	1	POWER SUPPLY MOUNTNG BAR	28480	08757-20071
4	08757-00006	2	1	DIVIDER	28480	08757-00006
5	08757-00012	0	1	SEPARATOR	28480	08757-00012
6	08757-00028	8	1	LOGGER ENCLOSURE	28480	08757-00028
7	08757-00037	9	1	RIGHT SUPPORT	28480	08757-00037
8	0515-0886	3	30	SCREW-MACH M3 X 0.5 6MM-LG PAN HD	00000	ORDER BY DESC.
9	5040-0170	6	1	PC SUPPORT	28480	5040-0170
10	08757-00055	1	1	CRT SHIELD	28480	08757-00055
11	08757-20030	4	1	ACTUATOR ROD	28480	08757-20030
12	08757-40008	8	1	SWITCH GUIDE	28480	08757-40008
13	1460-1573	1	1	EXTENSION SPRING	28480	1460-1543
14	0515-1367	7	3	SCREW-MACH M4	00000	ORDER BY DESC.
15	1400-0510	8	1	CLIP	28480	1400-0510

Figure 6-2. Cage Assembly and CRT Shield (8 of 9)



Reference Designation	HP Part Number	CD	Qty	Description	Mfr Code	Mfr Part Number
1	5021-8405	6	1	FRONT FRAME	28480	5021-8405
2	5021-5806	5	1	REAR FRAME	28480	5021-5806
3	5062-3990	0	1	FRONT HANDLE KIT	28480	5062-3990
4	5021-8497	6	2	FRONT HANDLE TRIM (P/O ITEM 3)	28480	5021-8497
5	5041-8802	9	1	TOP TRIM STRIP	28480	5041-8802
6	5041-8801	9	4	BOTTOM FOOT	28480	5041-8801
7	1460-1345	5	2	TILT STAND	28480	1460-1345
8	5041-8819	8	1	STRAP HANDLE END COVER (FR)	28480	5041-8819
9	5041-8820	1	1	STRAP HANDLE END COVER (FM)	28480	5041-8820
10	5062-3703	3	1	STRAP HANDLE	28480	5062-3703
11	5001-0540	2	2	SIDE TRIM STRIP	28480	5001-0540
12	5021-5836	1	4	CORNER STRUT	28480	5021-5836
13	5062-3734	0	1	TOP COVER (FM)	28480	5062-3734
14	5062-3746	4	1	BOTTOM COVER (FM)	28480	5062-3746
15	5062-3816	9	1	PERFORATED SIDE COVER W/ HANDLE RECESS	28480	5062-3816
16	5062-3841	0	1	PERFORATED SIDE COVER	28480	5062-3841
17	08757-80084		1	FRONT DRESS PANEL (STND) See next page for options	28480	08757-00040
18	08757-00062	8	1	FRONT SUBPANEL	28480	08757-00062
19	08757-00035	7	1	REAR PANEL	28480	08757-00035
20	5062-3978	4	1	P/O RACK MOUNT W/O HANDLE KIT (OPT 908)	28480	5062-3978
21	5062-4072	1	1	P/O RACK MOUNT WITH HANDLE KIT (OPT 913)	28480	5062-4072
22	5041-8801	4	4	CORNER FOOT		5021-5836
23	0515-1402	4	4	SMM 3.5 8PNPTY		0515-1402

Figure 6-2. Frame Exploded View (9 of 9)

**Replaceable Parts List (1 of 2)**

HP Part Number	Qty	Description	Mfr Code	Mfr Part Number
<b>OPTIONS</b>				
<b>HP 8757D OPTION 001</b>				
08757-80085	1	FRONT DRESS PANEL	28480	08757-80085
08757-60034	1	P/O DETECTOR INTERFACE ASSY	28480	08757-60034
2190-0584	2	WASHER-LK HLCL 3.0MM 3.1-MM-ID	28480	2190-0584
0535-0004	2	NUT-HEX DBL-CHAM M3 X 0.5 2.4MM-THK	28480	0535-0004
08757-60058	1	LOG AMPLIFIER	28480	08757-60058
<b>HP 8757D OPTION 002</b>				
08757-80086	1	FRONT DRESS PANEL	28480	08757-80086
08757-60111	1	MOD/CAL BOARD ASSSEMBLY	28480	08757-60111
08485-60005	1	ADAPTER NF-3.5m	28480	08485-60005
2190-0104	1	WSHR-LK .439 ID	28480	2190-0104
2950-0132	2	NUT-HEX 7/16-28	28480	2950-0132
<b>HP 8757D OPTION 001/002</b>				
08757-80083	1	FRONT DRESS PANEL	28480	08757-80083
08757-60111	1	MOD/CAL ASSEMBLY	28480	08757-60111
08757-60034	1	P/O DETECTOR INTERFACE ASSY	28480	08757-60034
2190-0584	2	WASHER-LK HLCL 3.0MM 3.1-MM-ID	28480	2190-0584
0535-0004	2	NUT-HEX DBL-CHAM M3 X 0.5 2.4MM-THK	28480	0535-0004
08757-60058	1	LOG AMPLIFIER	28480	08757-60058
08485-60005	1	ADAPTER NF-3.5m	28480	08485-60005
2190-0104	1	WSHR-LK .439 ID	28480	2190-0104
2950-0132	2	NUT-HEX 7/16-28	28480	2950-0132
<b>HP 8757D OPTION 802</b>				
8120-3445	1	CABLE ASSY 24C HP-IB	28480	8120-3445
HP 9122C	1	DISC DRIVE	28480	HP 9122C
<b>HP 8757D OPTION 908</b>				
5062-3987	1	RACK MOUNT KIT WITHOUT HANDLES	28480	5062-3987
<b>HP 8757D OPTION 913</b>				
5062-4072	1	RACK MOUNT KIT WITH HANDLES	28480	5062-4072
<b>HP 8757D OPTION 910</b>				
08757-90107	1	HP 8757D O/S MANUAL SET	28480	08757-90107
<b>UPGRADE/RETROFIT/SERVICE KITS</b>				
HP 86383A		HP 8757E TO HP 8757D UPGRADE KIT	28480	HP 86383A
HP 86383B		HP 8757C TO HP 8757D UPGRADE KIT	28480	HP 86383B
HP 86383C OPT 001		HP 8757D OPTION 001 RETROFIT KIT	28480	HP 86383C OPT 001
HP 86383C OPT 002		HP 8757D OPTION 002 RETROFIT KIT	28480	HP 86383C OPT 002
HP 86383C OPT 001/002		HP 8757D OPTION 001/002 RETROFIT KIT	28480	HP 86383C OPT 001/002
08757-60048		HP 8757D SERVICE KIT	28480	08757-60048
<b>DOCUMENTATION</b>				
08757-90107	1	HP 8757D O/S MANUAL SET	28480	08757-90107
08757-90109		HP 8757D OPERATING MANUAL	28480	08757-90109
08757-90110		HP 8757D SERVICE MANUAL	28480	08757-90110
08757-90074		HP 8757D SCALAR NTWK ANALYZERS USER'S GUIDE		08757-90074
08757-90075		INTRO PROGRAMMING GUIDE FOR THE HP 8757D SCALAR NTWK ANALYZER WITH THE HP 9000 SERIES 200/300 DESKTOP COMPUTER (BASIC)	28480	08757-90075
08757-90076		INTRO PROGRAMMING GUIDE FOR THE HP 8757D SCALAR NTWK ANALYZER WITH THE HP VECTRA PERS CMPTR USING MICROSOFT QUICKBASIC 4.0	28480	08757-90076
08757-90077		QUICK REFERENCE GUIDE FOR THE HP 8757D SCALAR NETWORK ANALYZER	28480	08757-90077



*Replaceable Parts List (2 of 2)*

HP Part Number	Qty	Description	Mfr Code	Mfr Part Number
08510-90064		MICROWAVE CONNECTOR CARE	28480	08510-90064
5952-6664		HP 8757D SCALAR NETWORK ANALYZERS TECHNICAL DATA SHEET	28480	5952-6664
5954-1566		CONNECTOR CARE APPLICATION NOTE	28480	5954-1566
5952-0156		TUTORIAL DESCRIPTION OF THE HP-IB	28480	5952-0156
5953-8866		INTRO OPERATING GUIDE FOR THE HP 8350B SWEEP OSCILLATOR WITH THE HP 9000 SERIES COMPUTERS (BASIC)	28480	5953-8866
5953-8866		QUICK REFERENCE GUIDE FOR THE HP 8550B SWEEP OSCILLATOR	28480	5953-8866
5952-9337		INTRO OPERATING GUIDE FOR THE HP 8340A SYNTHESIZED SWEEPER WITH THE HP 9000 SERIES 200 COMPUTERS (BASIC)	28480	5952-9337
5954-1591		QUICK REFERENCE GUIDE FOR THE HP 8340B SYNTHESIZED SWEEPER	28480	5954-1591
59401-90030		CONDENSED DESCRIPTION OF THE HP-IB	28480	59401-90030
82990-90001		HP 82990A HP-IB COMMAND LIBRARY MANUAL	28480	82990-90001
		<b>PACKAGING</b>		
08756-80009	1	CARTON - INNER	28480	08756-80009
08756-80010	2	SIDE RAIL FOAM PAD	28480	08756-80010
08756-80011	1	CARTON - REAR SPACES	28480	08756-80011
9211-4499	1	CARTON - OUTER	28480	9211-4499
		<b>MISCELLANEOUS</b>		
8500-2163		CLEANER FOR OPTICAL COMPONENTS	28480	8500-2163
HP 10833		HP-IB CABLES	28480	HP 10833
		SYSTEM II PLUS CABINET TOUCH-UP PAINT		
6010-1146		DOVE GRAY	28480	6010-1146
6010-1147		FRENCH GRAY	28480	6010-1147
6010-1148		PARCHMENT GRAY	28480	6010-1148
6010-1140		COBBLESTONE GRAY	28480	6010-1140
8710-1833		GSP EXTRACTOR TOOL	28480	8710-1833
		<b>LABELS</b>		
7120-6853		HP-IB ADDRESS LABEL	28480	7120-6853
7120-4163		WARNING LABEL .5-IN-WD 1-IN-LG AL	28480	7120-4163
7120-4293		WARNING LABEL 1-IN-WD 2-IN-LG AL	28480	7120-4293
		<b>FUSES</b>		
2110-0083		FUSE (INCH) 2.5A 250V NTD FE UL	00000	ORDER BY DESC.
2110-0043		FUSE (INCH) 1.5A 250V NTD FE UL	00000	ORDER BY DESC.

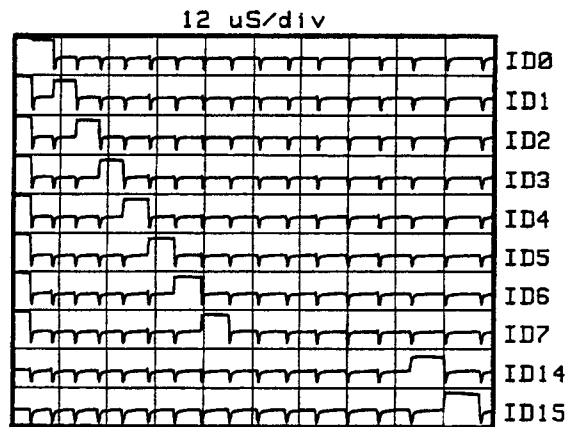


## ROTATE

This test is particularly helpful to find missing, shorted, or stuck data bits. This test sends a *rotating 1* data pattern to the address selected. The data pattern is a sixteen-bit word, with one bit high and the remaining fifteen low. Each successive bit (D0 through D15) is written high in turn. The test is continuous and repetitive with a trigger pulse available at the CONTROL1 output on the rear panel. A typical hex data rotate waveform for several instrument bus data lines is shown in Figure 8-3.

### CAUTION

Never attempt to perform a hex data rotate on EEPROM (address 0C0000 to 0FFFFE) with the write-protect switch closed. The EEPROMs can accept only a limited number of write cycles. Because this test repeats continuously, it will quickly destroy the memory retention capability of the EEPROMs.



Hex rotate to instrument bus  
showing part of walking '1' pattern.  
Note increasing width of each pulse.

Figure 8-3. Hex Data Rotate Waveforms

Table 8-5. Operator-Initiated Diagnostic Tests (1 of 2)

The service menu is accessed by pressing **PRESET** **SYSTEM** **MORE** **SERVICE**.

Menu Level within Service Menu				
1	2	3	4	5
DISPLAY	NOMINAL INT ADJ	SAVE VALUE PRIOR MENU		
	MINIMUM INT ADJ	SAVE VALUE PRIOR MENU		
	BCKGRND ADJUST	SAVE VALUE PRIOR MENU		
	TEST PATTERN	PRIOR MENU EXIT SERVICE		
	DISPLAY TEST	REPEAT CYCLE <sup>1</sup> PRIOR MENU EXIT SERVICE		
	MORE	BCKGRND RAMP <sup>1</sup> INTNSTY RAMP <sup>1</sup> PRIOR MENU EXIT SERVICE		
	PRIOR MENU EXIT SERVICE			
HEX TESTS	ADDRESS	ADDRESS READ WRITE ROTATE <sup>1</sup> PRIOR MENU EXIT SERVICE		
	PRIOR MENU EXIT SERVICE			
A1/2 FP	READ RPG <sup>1</sup> READ KEY <sup>1</sup> CYCLE <sup>1</sup> LEDS <sup>1</sup> PRESET DISABLE <sup>1</sup> CLOCK	SYNC SECONDS SET MINUTES SET HOUR SET DAY SET MONTH SET YEAR PRIOR MENU		
	PRIOR MENU EXIT SERVICE			
A3 CPU	RAM TEST	REPEAT PRIOR MENU EXIT SERVICE		
	TIMER <sup>1</sup> EEROM TEST	EXECUTE PRIOR MENU EXIT SERVICE		
	READ STATUS <sup>1</sup> INTRPT PRIOR MENU EXIT SERVICE			
A4 ADC	ADC MEAS	DATA READY <sup>1,2</sup> READ DATA <sup>1,2</sup>		

1. Indicates a cycling self-test with an oscilloscope trigger pulse available at the CONTROL 1 BNC connector on the rear panel, even though test results displayed on the CRT are not necessarily updated. This feature is very useful for troubleshooting.

2. Indicates a failure mode menu that appears only when the previous level test has failed.

Table 8-5. Operator-Initiated Diagnostic Tests (2 of 2)

The service menu is accessed by pressing **PRESET** **SYSTEM** **MORE** **SERVICE**.

Menu Level within Service Menu				
1	2	3	4	5
A4 ADC (cont'd)	ADC BIT CHECK DAC BIT CHECK DET CONTROL <sup>1</sup>	MODE 1 <sup>2</sup> MODE 2 <sup>2</sup> MODE 3 <sup>2</sup> CHANV DETDAC <sup>1,2</sup> PRIOR MENU <sup>2</sup> EXIT SERVICE <sup>2</sup>		
	SWEEP COMPARE	BLANK <sup>1,2</sup> SWEEP TOO FAST <sup>1,2</sup> RETRACE <sup>1,2</sup> MARKER <sup>1,2</sup> PRIOR MENU <sup>2</sup> EXIT SERVICE <sup>2</sup>		
	MORE	RAMP <sup>1</sup> CHANNEL VOLTS	CHANV LOGGER <sup>1</sup> CHANV DETDAC <sup>1</sup>	DET DAC ENTER DET DAC MAX DET DAC MIN MODE 1 MODE 2 MODE 3 PRIOR MENU EXIT SERVICE
A6 HPIB INSTBUS	PRIOR MENU HPIB TESTS	DATA READY <sup>1</sup> READ DATA <sup>1</sup> PRIOR MENU EXIT SERVICE	CHANV OTHER <sup>1</sup>	SWP DAC ENTER SWP DAC MAX SWP DAC MIN PRIOR MENU EXIT SERVICE
	INSTBUS TESTS	HPIB TALK HPIB LISTEN PRIOR MENU EXIT SERVICE	PRIOR MENU EXIT SERVICE	
INST VERIFY EXIT SERVICE	PRIOR MENU EXIT SERVICE	REPEAT CYCLE <sup>1</sup> PRIOR MENU EXIT SERVICE		

1. Indicates a cycling self-test with an oscilloscope trigger pulse available at the CONTROL 1 BNC connector on the rear panel, even though test results displayed on the CRT are not necessarily updated. This feature is very useful for troubleshooting.

2. Indicates a failure mode menu that appears only when the previous level test has failed.

## OVERALL INSTRUMENT DESCRIPTION

Refer to Figure 8–4, “HP 8757D Simplified Block Diagram”.

The HP 8757D Scalar Network Analyzer is a microprocessor–based receiver for making scalar (magnitude only) transmission and reflection measurements on microwave devices. Any of three inputs in the standard instrument (A, B, and R) or four inputs in Option 001 (A, B, C, and R) may be chosen to make absolute or ratio measurements on four identical but independent measurement channels. In addition to the HP 8757D receiver, a typical measurement setup includes a swept microwave source, compatible microwave detectors, directional bridges, and couplers.

The analyzer uses either AC or DC detection techniques of scalar network analysis. In AC detection, the microwave source is amplitude modulated on and off at 27.778 kHz with a 50% duty cycle square wave. External detectors peak detect the microwave signal after it has passed through any device under test or directional accessories. In DC detection, an AC/DC detector or bridge modulates the detected signal at 27.778 kHz. This eliminates the need for amplitude modulation of the source. Although the square wave frequency is fixed at 27.778 kHz (regardless of the microwave frequency), its amplitude corresponds to the power level of the microwave signal. Because the amplitude information is carried at 27.778 kHz, the analyzer is AC coupled and tuned to 27.778 kHz to reduce DC offset errors and noise.

### Overview

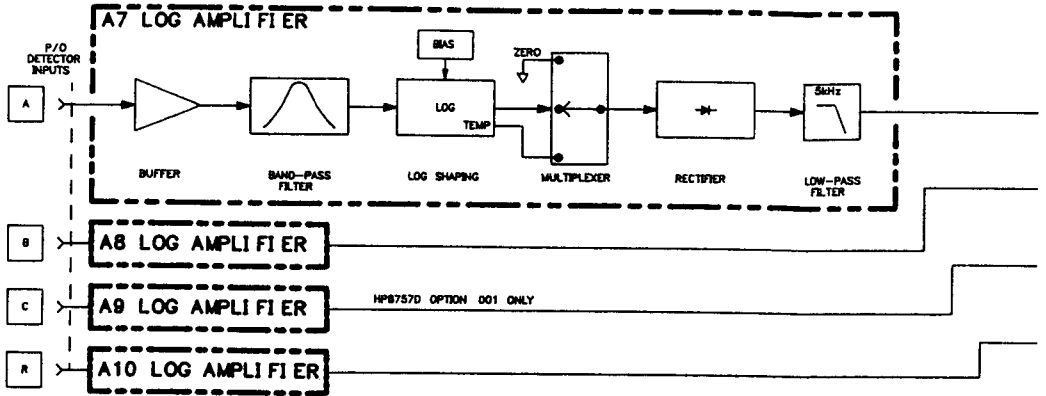
The A, B, C (Option 001), and R detector inputs are logarithmically shaped and rectified by identical log amplifiers A7, A8, A9, and A10. The outputs are DC voltages representing a microwave power level for each input. These analog signals are converted to digital data by the A4 ADC (analog–to–digital converter) and read by the A3 CPU (central processing unit). The A3 CPU processes the data and sends it to the A14 display interface which then formats it to be viewed on the A15 display. The A3 CPU also interfaces with the A1/A2 front panel, and can communicate with other instruments through the A6 HP–IB over two HP–IB ports. The A5 modulator driver provides a 27.778 kHz drive at the rear panel to amplitude modulate the microwave source or an external modulator, if required. The A12 power supply provides four supply voltages for the analyzer, as well as two independent supplies for the A14 display interface and A15 display.

### A7/A8/A9/A10 Log Amplifiers

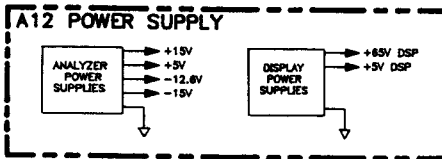
The A7/A8/A9/A10 log amplifiers buffer, filter, log, and rectify the front panel input signals. The output from each log amplifier is a DC voltage proportional to the 27.778 kHz modulation envelope being detected at each of the inputs.

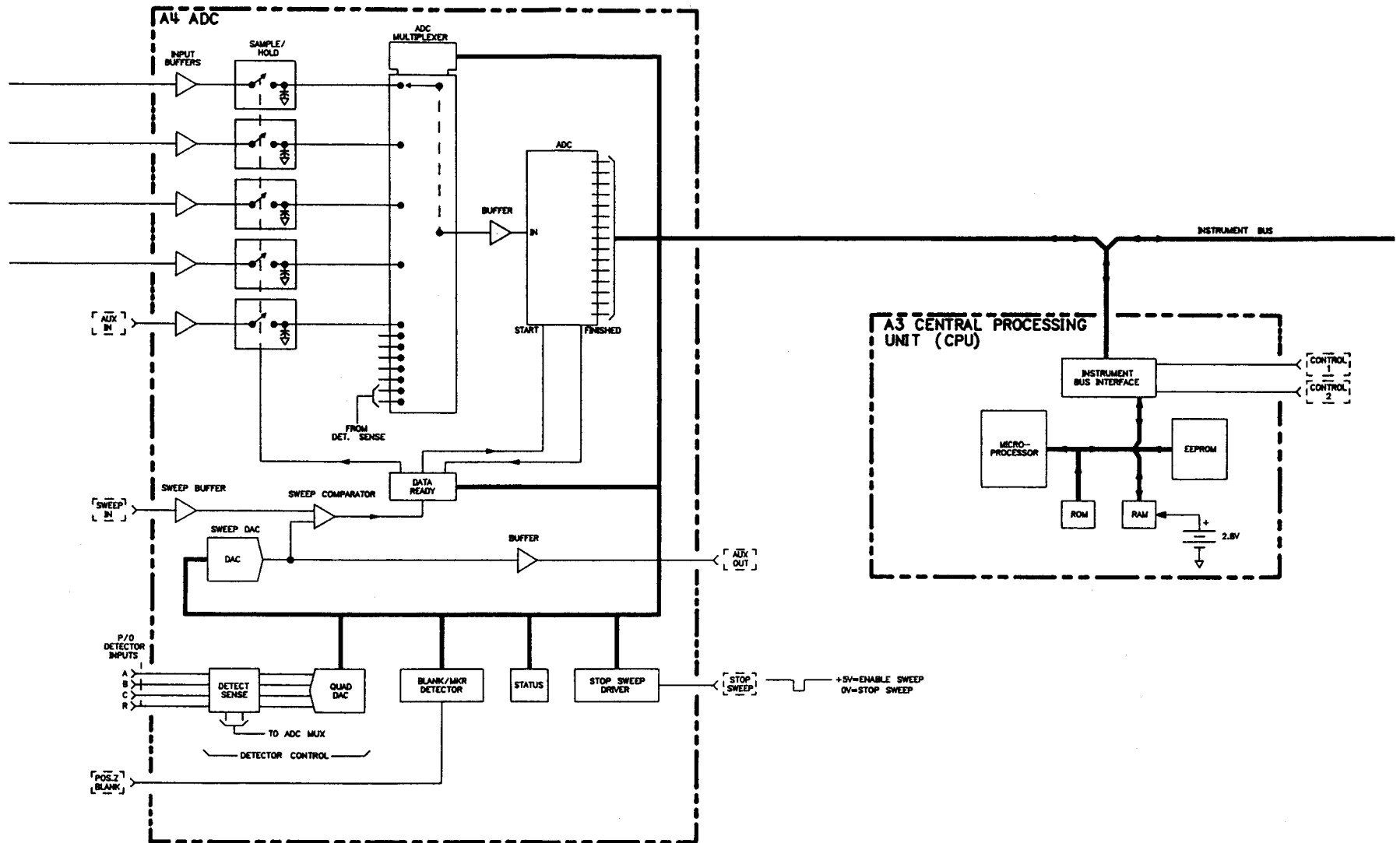
External microwave accessories (detectors or bridges) detect the 27.778 kHz amplitude modulated signal received. The amplitude of the 27.778 kHz detector output represents the microwave power level of the input. The A, B, C, and R inputs are connected to the A7, A8, A9, and A10 log amplifiers respectively. The buffer at the input of each log amplifier assembly isolates the signal and eliminates common–mode noise. A bandpass filter with a 27.778 kHz center frequency further reduces noise and filters the square wave into a sine wave. The logarithmic amplifier circuit produces an output waveform proportional to the logarithm of its input signal. This output waveform represents the input in dB. The precision rectifier then peak detects the log shaped 27.778 kHz sine wave, producing a DC voltage proportional to the 27.778 kHz detector output in dB.

# 8757 SIMPLIFIED BLOCK DIAGRAM

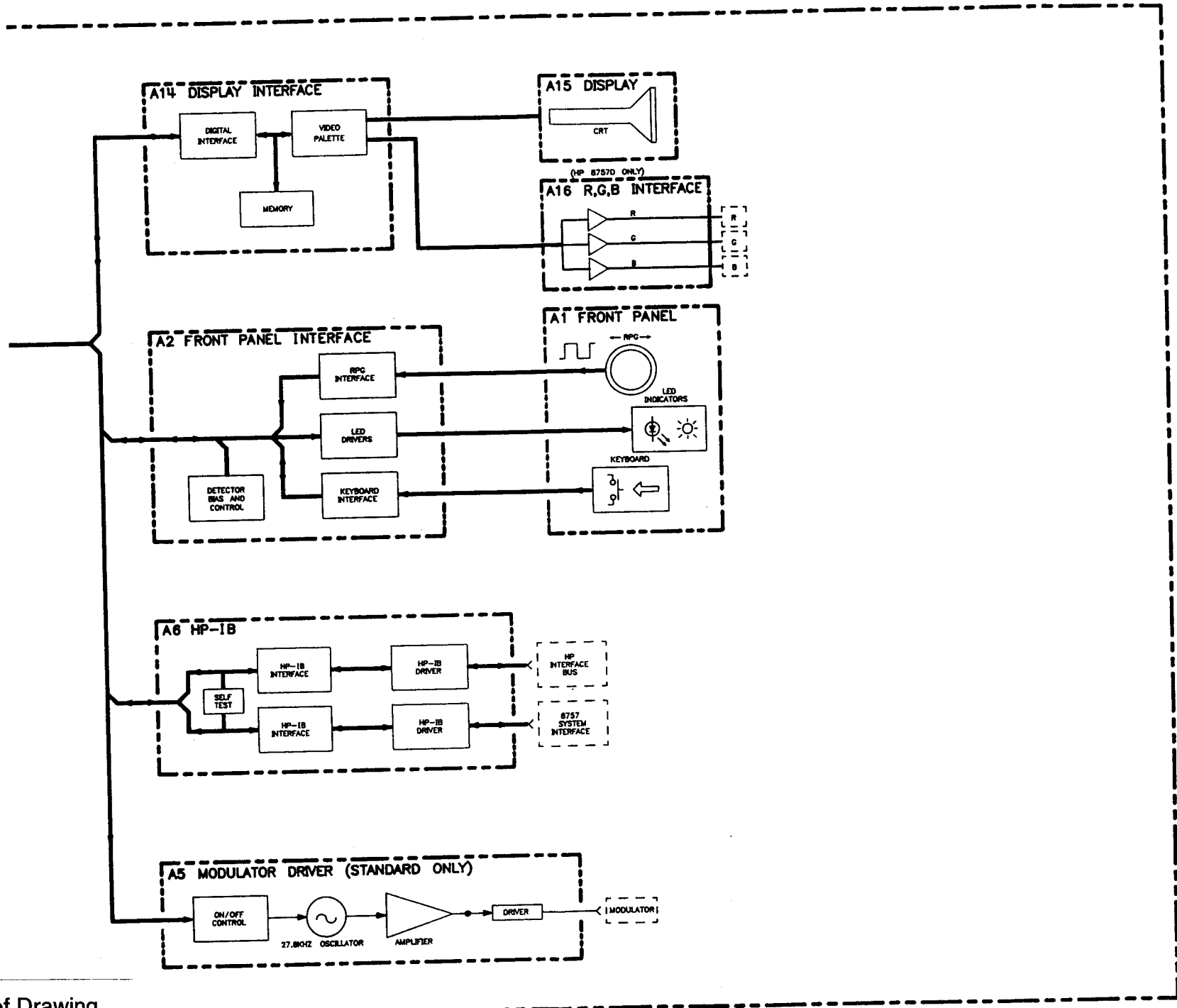


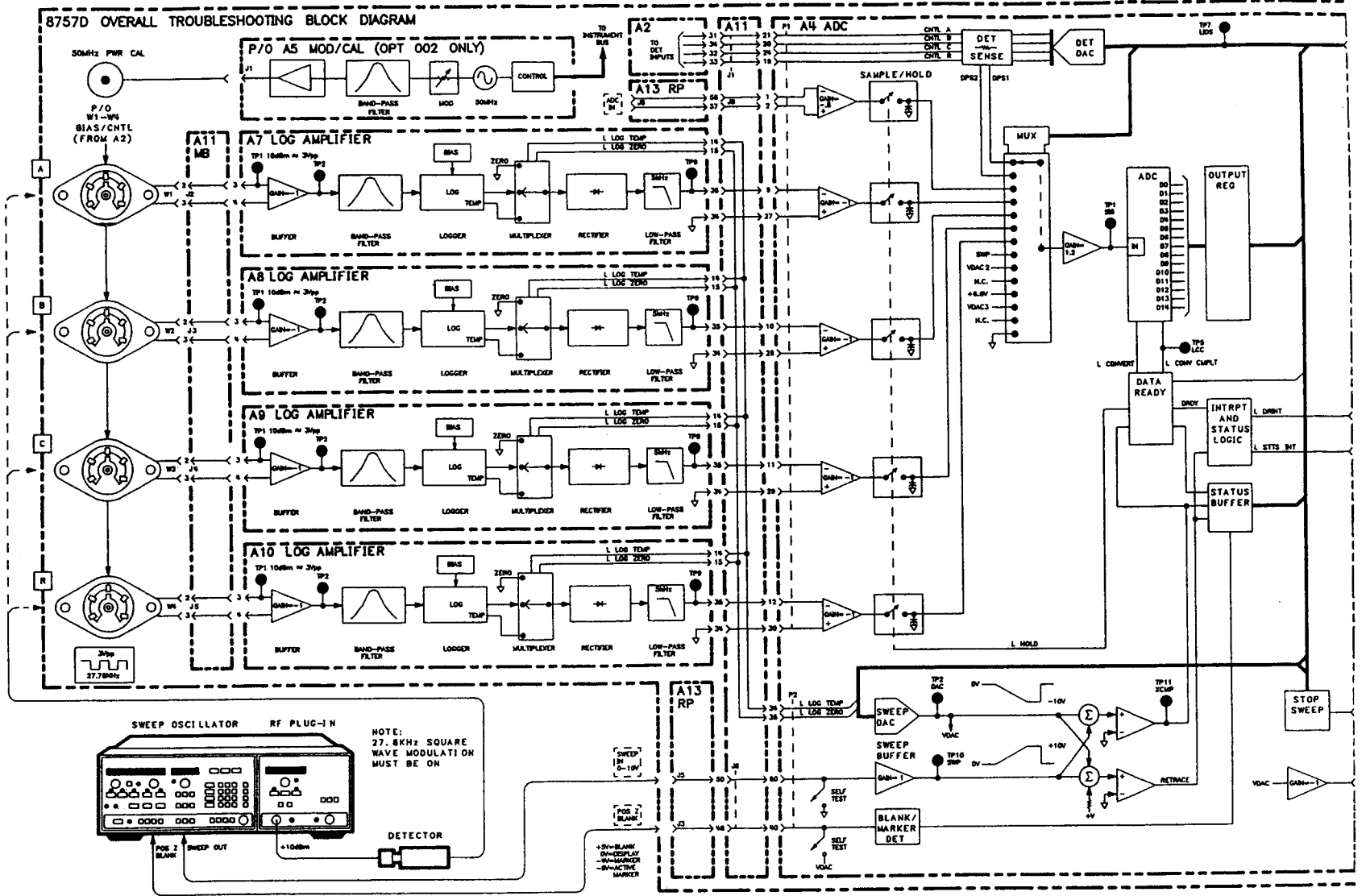
NOTE: ALL LOG AMPS ARE IDENTICAL











1 of 2 Left Side of Drawing

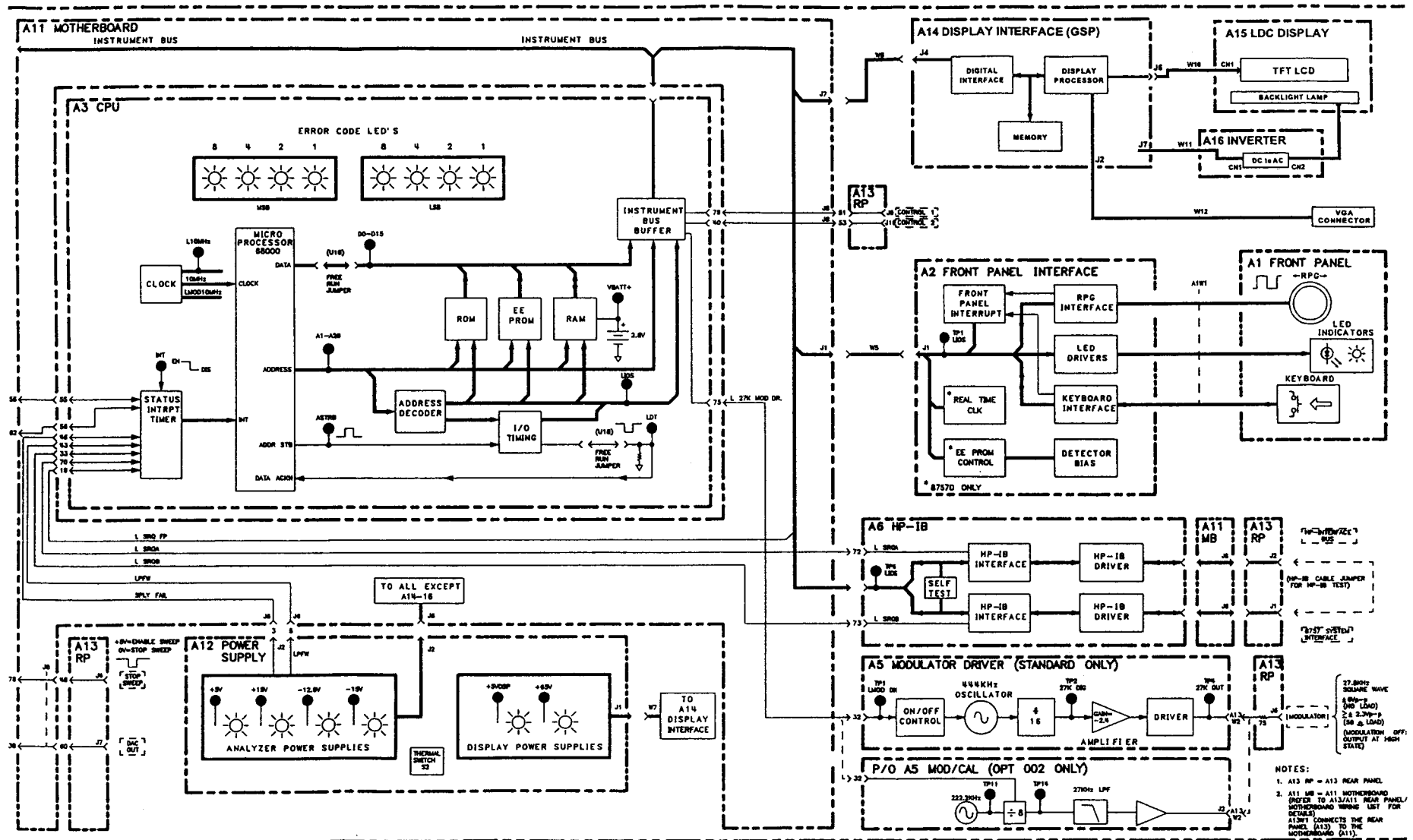


Figure 8-5. 8757 Overall Troubleshooting Block Diagram

2 of 2 Right Side of Drawing

If this check fails, verify the address lines to the A2 front panel interface by running the CYCLE test. If the keyboard does not function, close switch A3S1–C, then press PRESET or ground A3TP46 (L PRST) to run the test. While the front panel cycle test is running, all the address decoder outputs used are enabled in turn. Examine each with an oscilloscope for activity similar to the waveforms shown in Figure 8–3. If these waveforms are not present, trace the problem to A2U3, or trace the address lines back to the A3 CPU. Also check for activity on L IOSTB.

In addition, while the front panel cycle test is running, the A3 CPU writes a data pattern to the column strobing latch. Examine the outputs of A2U11 for a “walking 1” pattern. If this is missing, suspect A2U11 or the data line connections. The keyboard matrix itself can be tested with the front panel CYCLE test. (However, the front panel READ KEY diagnostic test is much easier, if it can be run.) The column strobing lines are automatically exercised. Press any key, and verify that the corresponding row sensing line follows the corresponding column strobing line. Use a dual trace oscilloscope to verify timing relationships and rule out shorts. When a key is pressed, a 7 ms upward pulse should be visible at the appropriate row sensing line. Use the rear panel CONTROL 1 output to trigger the oscilloscope. This makes it easier to check timing relationships.

## LEDS

If the LEDs appear burned out, press and hold preset. All LEDs, including the eight red LEDs on the A3 CPU, should light. If none of the LEDs light, check the preset functions and the L RESET line. If one LED does not light, suspect a bad LED.

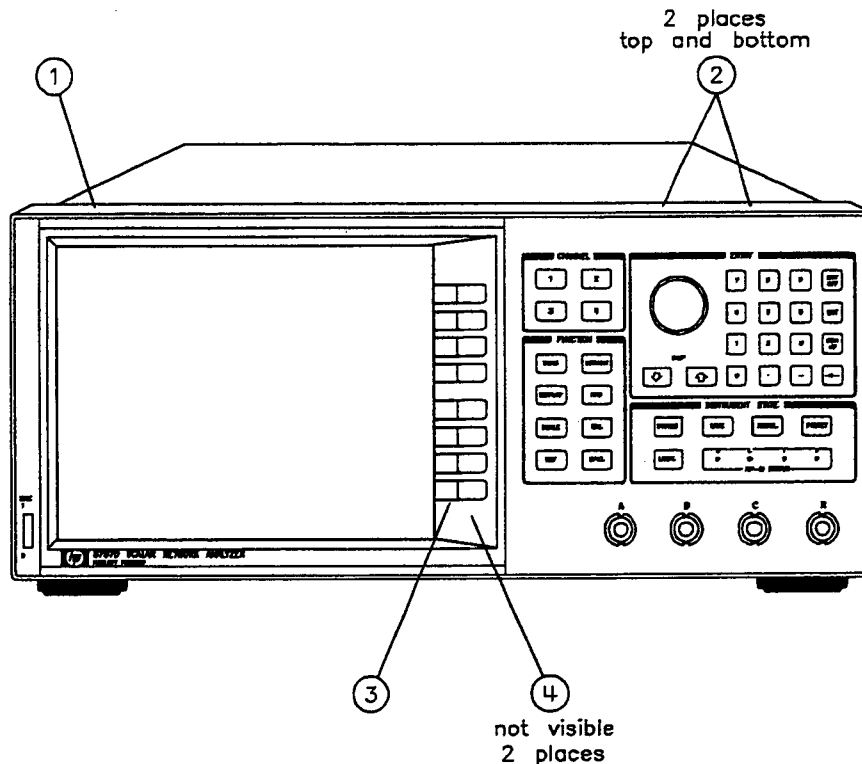
Run the LEDS diagnostic test. All front panel LEDs should light, one at a time, in sequence. This test fully verifies LED address decoding and the data lines.

## RPG (Rotary Pulse Generator)

Run the READ RPG diagnostic test. The display indicates the present count from the RPG counter. (The RPG counter is reset upon entering the RPG test, but not again during the test.) Rotate the RPG clockwise to increment the count, counterclockwise to decrement the count. If the displayed count does not change, suspect the clock line of the RPG. Verify the counter U13 with an oscilloscope. If the direction of the count does not change, suspect the RPG’s up/down line.

Verify the RPG counter reset line, L CLR RPG, by exiting the read RPG test while the RPG counter indicates a count other than 0000. Re–enter the read RPG test and verify that the displayed count is now 0000.

## FRONT PANEL REMOVAL PROCEDURE



*Figure 8-7. Front Panel Removal*

To remove the front panel from the analyzer, refer to figure above. The side handles do not need to be removed.

At the left edge of the front panel, snap out the softkey button cover (item 3) by inserting a credit card or your fingernail under the cover's left edge and pivoting it out and off. Remove the two round-head machine screws now visible (item 4). Pivot the bezel, with glass filter, out until it releases from the left edge.

Pop off the top trim strip (item 1). Remove the two flat-head machine screws (item 2) revealed on the top right side of the instrument. Place the entire instrument on its left side. Remove the two flat-head machine screws holding the front panel in place at the bottom of the frame (item 2).

The front panel is now held in place by friction only. Its only connections are the cables near its lower edge. You can pivot the top edge of the front panel outward and down for access.

Reinstall the front panel by reversing this sequence.

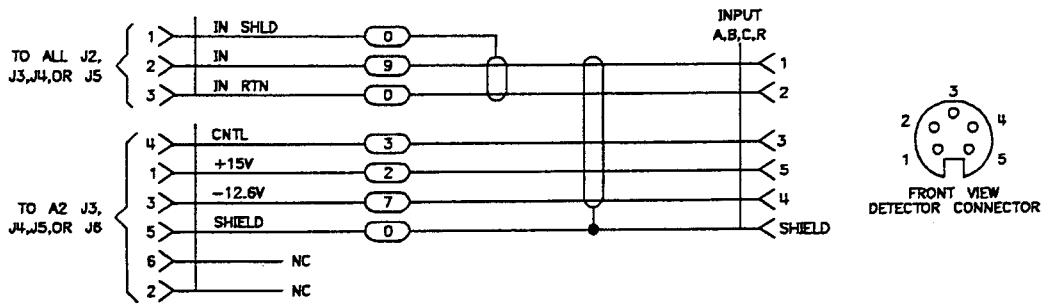


Figure 8-8. W1-4 Detector Interface Cable Schematic

Replaceable Parts List for A1 Assembly (1 of 1)

Reference Designation	HP Part Number	Qty	Description	Mfr Code	Mfr Part Number
A1	08757-60112	1	FRONT PANEL KEYBOARD ASSEMBLY	28480	08757-60112
A1MP2	0380-3079	4	SPCR .280L.120ID	28480	08380-3079
A1DS1 - 4	1990-0858	4	LED YEL	28480	1990-0858
A1J1	1251-8579	1	CONN HDR	28480	1251-8579
A1W1	08757-60045	1	CBL AY 28C 28G	28480	08757-60045

See Figure 6-2 for other front panel related items.

*Replaceable Parts List for A2 Assembly (1 of 2)*

Reference Designation	HP Part Number	Qty	Description	Mfr Code	Mfr Part Number
A2	08757-60113	1	BD AY-FP INTRFC	28480	08757-60113
A2C1	0180-3849	1	CAP-FXD 47uF ±10% 10 V TA	04200	299D476X9010DB1
A2C2	0160-4084	1	CAP-FXD 0.1uF ±20% 50 V CER X7R	09939	RPE122-139X7R104M50V
A2C3-C8	0180-3845	1	CAP-FXD 4.7uF ±10% 35 V TA	04200	299D475X9035CB1
A2C9-C16	0160-4084	1	CAP-FXD 0.1uF ±20% 50 V CER X7R	09939	RPE122-139X7R104M50V
A2C17-C18	0180-3845	1	CAP-FXD 4.7uF ±10% 35 V TA	04200	299D475X9035CB1
A2C19	0160-4801	1	CAP-FXD 100pF ±5% 100 V CER C0G	09939	RPA10C0G101J100V
A2C20	0160-4441	1	CAP-FXD 0.47uF ±10% 50 V CER X7R	09939	RPE113-130X7R474K50V
A2C21	0160-4832	1	CAP-FXD 0.1uF ±20% 100 V CER X7R	09939	RPE122-139X7R104M50V
A2C22	0160-4084	1	CAP-FXD 0.1uF ±20% 50 V CER X7R	09939	RPE122-139X7R104M50V
A2C23-C24	0180-3845	1	CAP-FXD 4.7uF ±10% 35 V TA	04200	299D475X9035CB1
A2C25-C26	0160-4441	1	CAP-FXD 0.47uF ±10% 50 V CER X7R	09939	RPE113-130X7R474K50V
A2C27-C28	0160-4084	1	CAP-FXD 0.1uF ±20% 50 V CER X7R	09939	RPE122-139X7R104M50V
A2C29	0180-3770	1	CAP-FXD 2.2uF ±10% 35 V TA	04200	299D225X9035BB1
A2C30	0160-4801	1	CAP-FXD 100pF ±5% 100 V CER C0G	09939	RPA10C0G101J100V
A2CR1-CR7	1901-0050	1	DIODE-SWITCHING 80V 200MA 2NS DO-35	03406	
A2CR8	1901-0731	1	DIODE-PWR RECT 400V 1A	02037	1N4004
A2CR9-CR15	1901-0050	1	DIODE-SWITCHING 80V 200MA 2NS DO-35	03406	
A2CR16	1901-0518	1	DIODE-SCHOTTKY SM SIG	02062	5082-5509
A2CR17	1901-0050	1	DIODE-SWITCHING 80V 200MA 2NS DO-35	03406	
A2CR18	1901-0518	1	DIODE-SCHOTTKY SM SIG	02062	5082-5509
A2DL1	1810-1272	1	DELAY LINE ACTIVE DEVICE W/DUAL IN-LINE	12186	DS1000M-100
A2J1	1251-8828	1	CONN-POST TYPE .100-PIN-SPCG 40-CONT	04726	2540-6002UB
A2J2	1251-8248	1	CONN-POST TYPE .100-PIN-SPCG 26-CONT	04726	2526-6002UB
A2J3-J6	1251-6515	1	CONN-POST TYPE .100-PIN-SPCG 6-CONT	02946	67996-606
A2L1	08503-80001	1	COIL-TORROID		
A2L2	9100-2573	1	INDUCTOR RF-CH-MLD 1MH ±10%	28480	9100-2573
A2L3	9100-2578	1	INDUCTOR RF-CH-MLD 2.7MH ±10%	28480	9100-2578
A2L4	9100-2573	1	INDUCTOR RF-CH-MLD 1MH ±10%	28480	9100-2573
A2L5	9100-2578	1	INDUCTOR RF-CH-MLD 2.7MH ±10%	28480	9100-2578
A2L6	9100-2573	1	INDUCTOR RF-CH-MLD 1MH ±10%	28480	9100-2573
A2L7	9100-2578	1	INDUCTOR RF-CH-MLD 2.7MH ±10%	28480	9100-2578
A2L8	9100-2573	1	INDUCTOR RF-CH-MLD 1MH ±10%	28480	9100-2573
A2L9	9100-2578	1	INDUCTOR RF-CH-MLD 2.7MH ±10%	28480	9100-2578
A2L10	9100-2573	1	INDUCTOR RF-CH-MLD 1MH ±10%	28480	9100-2573
A2L11	9100-2578	1	INDUCTOR RF-CH-MLD 2.7MH ±10%	28480	9100-2578
A2L12	9100-2573	1	INDUCTOR RF-CH-MLD 1MH ±10%	28480	9100-2573
A2L13	9100-2578	1	INDUCTOR RF-CH-MLD 2.7MH ±10%	28480	9100-2578
A2L14	9100-2573	1	INDUCTOR RF-CH-MLD 1MH ±10%	28480	9100-2573
A2L15	9100-2578	1	INDUCTOR RF-CH-MLD 2.7MH ±10%	28480	9100-2578
A2L16	9100-2573	1	INDUCTOR RF-CH-MLD 1MH ±10%	28480	9100-2573
A2L17	9100-2578	1	INDUCTOR RF-CH-MLD 2.7MH ±10%	28480	9100-2578
A2MP2	0380-1247	4	SPACER-RVT-ON 8-MM-LG 3.8-MM-ID	02121	0380-1247
A2Q1	1855-0567	1	TRANSISTOR MOSFET P-CHAN E-MODE SI	03038	IRFD9123
A2Q3	1855-0518	1	TRANSISTOR MOSFET N-CHAN E-MODE SI	03038	IRFD110
A2Q4-Q6	1853-0007	1	TRANSISTOR PNP 2N3251 SI TO-18 PD=360MW	02037	2N3251
A2Q7	1854-0477	1	TRANSISTOR NPN 2N2222A SI TO-18 PD=500MW	02037	2N2222A
A2R1	0757-0401	1	RESISTOR 100 ±1% .125W TF TC=0±100	05524	
A2R2	0698-3155	1	RESISTOR 4.64K ±1% .125W TF TC=0±100	05524	
A2R3	0757-0346	1	RESISTOR 10 ±1% .125W TF TC=0±100	05524	
A2R4	1810-0374	1	NETWORK-RES 8-SIP 1.0K OHM X 4	02483	750-83-R1K
A2R5	0698-3162	1	RESISTOR 46.4K ±1% .125W TF TC=0±100	05524	

*Replaceable Parts List for A2 Assembly (2 of 2)*

Reference Designation	HP Part Number	Qty	Description	Mfr Code	Mfr Part Number
A2R6	0698-3446	1	RESISTOR 383 ±1% .125W TF TC=0±100	05524	
A2R8-R9	0757-0401	1	RESISTOR 100 ±1% .125W TF TC=0±100	05524	
A2R10	0698-3403	1	RESISTOR 348 ±1% .5W TF TC=0±100	05524	
A2R11	0757-0442	1	RESISTOR 10K ±1% .125W TF TC=0±100	05524	
A2R12	0698-3162	1	RESISTOR 46.4K ±1% .125W TF TC=0±100	05524	
A2R13	1810-0279	1	NETWORK-RES 10-SIP 4.7K OHM X 9	05524	MSP10A01-472G
A2R14	0757-0442	1	RESISTOR 10K ±1% .125W TF TC=0±100	05524	
A2R15	0757-0443	1	RESISTOR 11K ±1% .125W TF TC=0±100	05524	
A2R16	0698-4474	1	RESISTOR 8.45K ±1% .125W TF TC=0±100	05524	
A2R17	0757-0438	1	RESISTOR 5.11K ±1% .125W TF TC=0±100	05524	
A2R18-R21	0698-3162	1	RESISTOR 46.4K ±1% .125W TF TC=0±100	05524	
A2R22	1810-0316	1	NETWORK-RES 16-DIP 10.0K OHM X 8	02483	761-3-R10K
A2R23-R24	0698-3155	1	RESISTOR 4.64K ±1% .125W TF TC=0±100	05524	
A2R25-R30	0698-3155	1	RESISTOR 4.64K ±1% .125W TF TC=0±100	05524	
A2R31	0757-0442	1	RESISTOR 10K ±1% .125W TF TC=0±100	05524	
A2R32	0757-0279	1	RESISTOR 3.16K ±1% .125W TF TC=0±100	05524	
A2R33-R34	0757-3160	1	RESISTOR 31.6K ±1% .125W TF TC=0±100	05524	
A2R35	0757-0443	1	RESISTOR 11K ±1% .125W TF TC=0±100	05524	
A2R36	0757-0123	1	RESISTOR 34.8K ±1% .125W TF TC=0±100	05524	
A2R37-R38	0757-0442	1	RESISTOR 10K ±1% .125W TF TC=0±100	05524	
A2R39	0757-0443	1	RESISTOR 11K ±1% .125W TF TC=0±100	05524	
A2R40	0698-3260	1	RESISTOR 464K ±1% .125W TF TC=0±100	05524	
A2R41	0698-3446	1	RESISTOR 383 ±1% .125W TF TC=0±100	05524	
A2R42	0757-0280	1	RESISTOR 1K ±1% .125W TF TC=0±100	05524	
A2R43	0757-0438	1	RESISTOR 5.11K ±1% .125W TF TC=0±100	05524	
A2R44-R46	0757-0442	1	RESISTOR 10K ±1% .125W TF TC=0±100	05524	
A2R47	0757-0403	1	RESISTOR 121 ±1% .125W TF TC=0±100	05524	
A2R48	0757-0199	1	RESISTOR 21.5K ±1% .125W TF TC=0±100	05524	
A2R49	0698-3162	1	RESISTOR 46.4K ±1% .125W TF TC=0±100	05524	
A2R50	0698-3155	1	RESISTOR 4.64K ±1% .125W TF TC=0±100	05524	
A2R51	0698-3438	1	RESISTOR 147 ±1% .125W TF TC=0±100	05524	
A2R52	0698-0083	1	RESISTOR 1.96K ±1% .125W TF TC=0±100	05524	
A2R53	0698-0083	1	RESISTOR 1.96K ±1% .125W TF TC=0±100	05524	
A2TP1-TP7	1460-2201	1	SPRING RADIAL TEST POINT		
A2U1-U2	1820-2488	1	IC FF TTL/ALS D-TYPE POS-EDGE-TRIG	01698	SN74ALS74AN
A2U3	1826-0666	1	IC COMPARATOR LOW-OFS QUAD 14 PIN DIP-P	03406	LM339AN
A2U4	1826-2331	1	ANALOG MULTIPLEXER 4 CHNL 16 -DIP-P	02883	DG409DJ
A2U5	1820-3100	1	IC DCDR TTL/ALS BIN 3-TO-8-LINE 3-INP	01698	SN74ALS138N
A2U6	1820-3318	1	IC FF TTL/ALS D-TYPE POS-EDGE-TRIG COM	01698	SN74ALS273N
A2U7	08757-80077	1	PAL A2U7		
A2U8	1820-2773	1	IC GATE TTL/ALS NAND 8-INP	01698	SN74ALS30AN
A2U9-U10	1820-3145	1	IC DRVR TTL/ALS BUS OCTL	01698	SN74ALS244BN
A2U11-U12	1820-3318	1	IC FF TTL/ALS D-TYPE POS-EDGE-TRIG COM	01698	SN74ALS273N
A2U13	1820-3217	1	IC CNTR TTL/ALS BIN UP/DOWN SYNCHRO	01698	SN74ALS569AN
A2U14	1826-0994	1	IC V RGLTR-ADJ-NEG 1.2/37V 3-TO-92 PKG	03406	LM337LZ
A2U15-U16	1826-0138	1	IC COMPARATOR GP QUAD 14 PIN DIP-P	03406	LM339N
A2U17	1820-3505	1	IC CNTR TTL/ALS BIN UP/DOWN SYNCHRO	01698	SN74ALS191N
A2U18	1813-0863	1	CLK-OSC-XTAL STD 2.4576-MHZ 0.01%	12768	SG-531P-2.4576MHZ
A2U19	08757-80078	1	PAL A2U19		
A2U20	1820-3121	1	IC TRANSCEIVER TTL/ALS BUS OCTL	01698	SN74ALS245AN
A2U21	1826-2068	1	IC MISC 24 PIN DIP-P	12186	DS1287
A2VR1-VR16	1902-0956	1	DIODE-ZNR 8.2V 5% DO-35 PD=.4W TC=+.065C>02037	SZ30035-1	



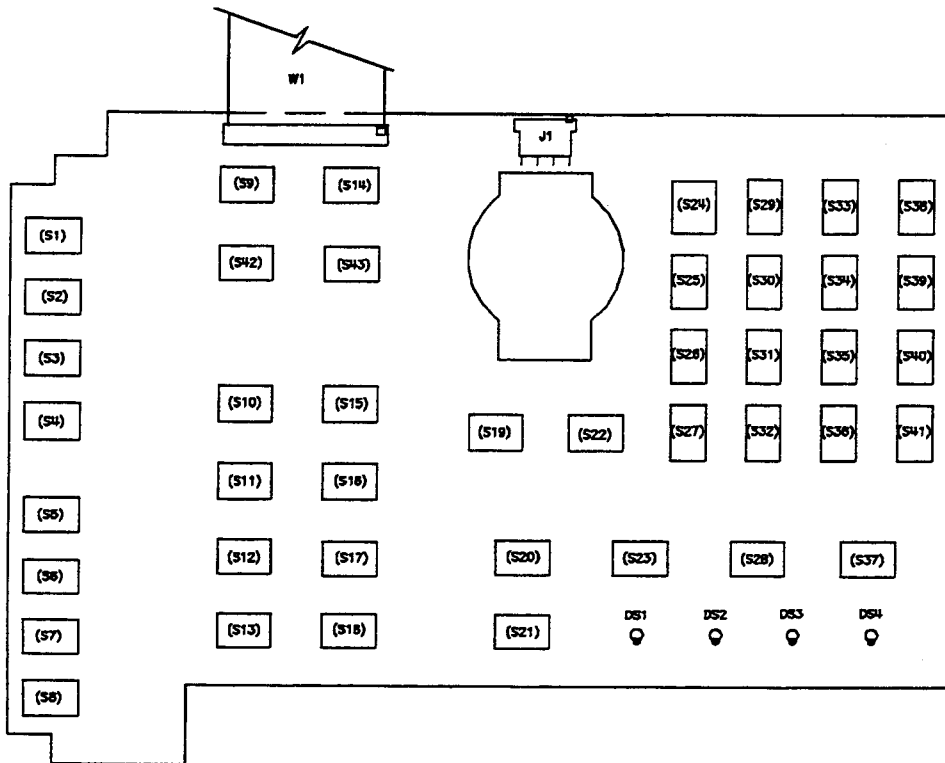


Figure 8-9. A1 Component Locations Diagram

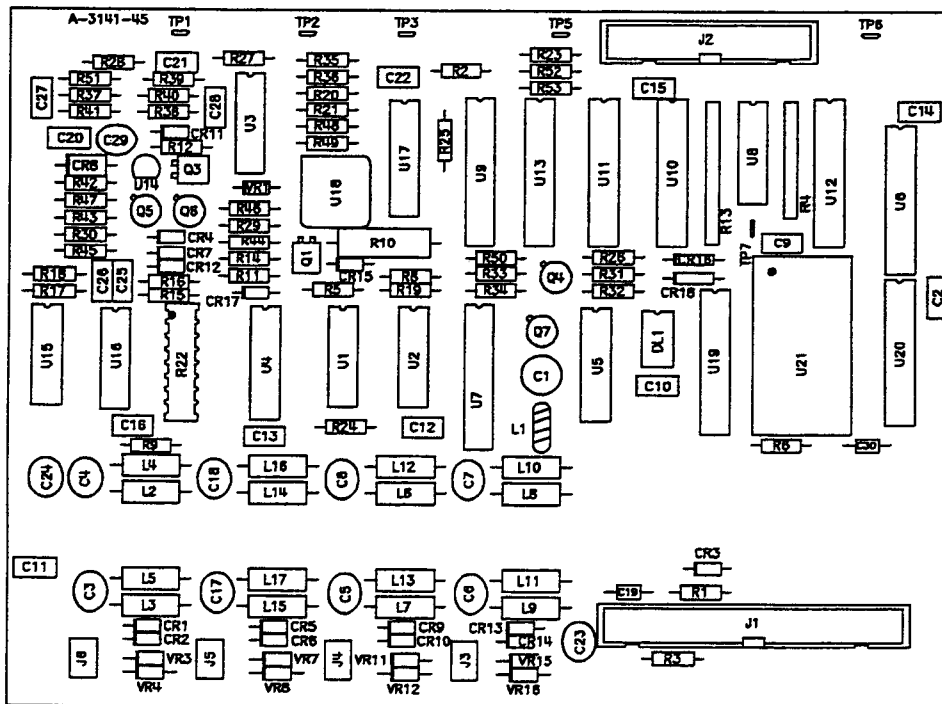
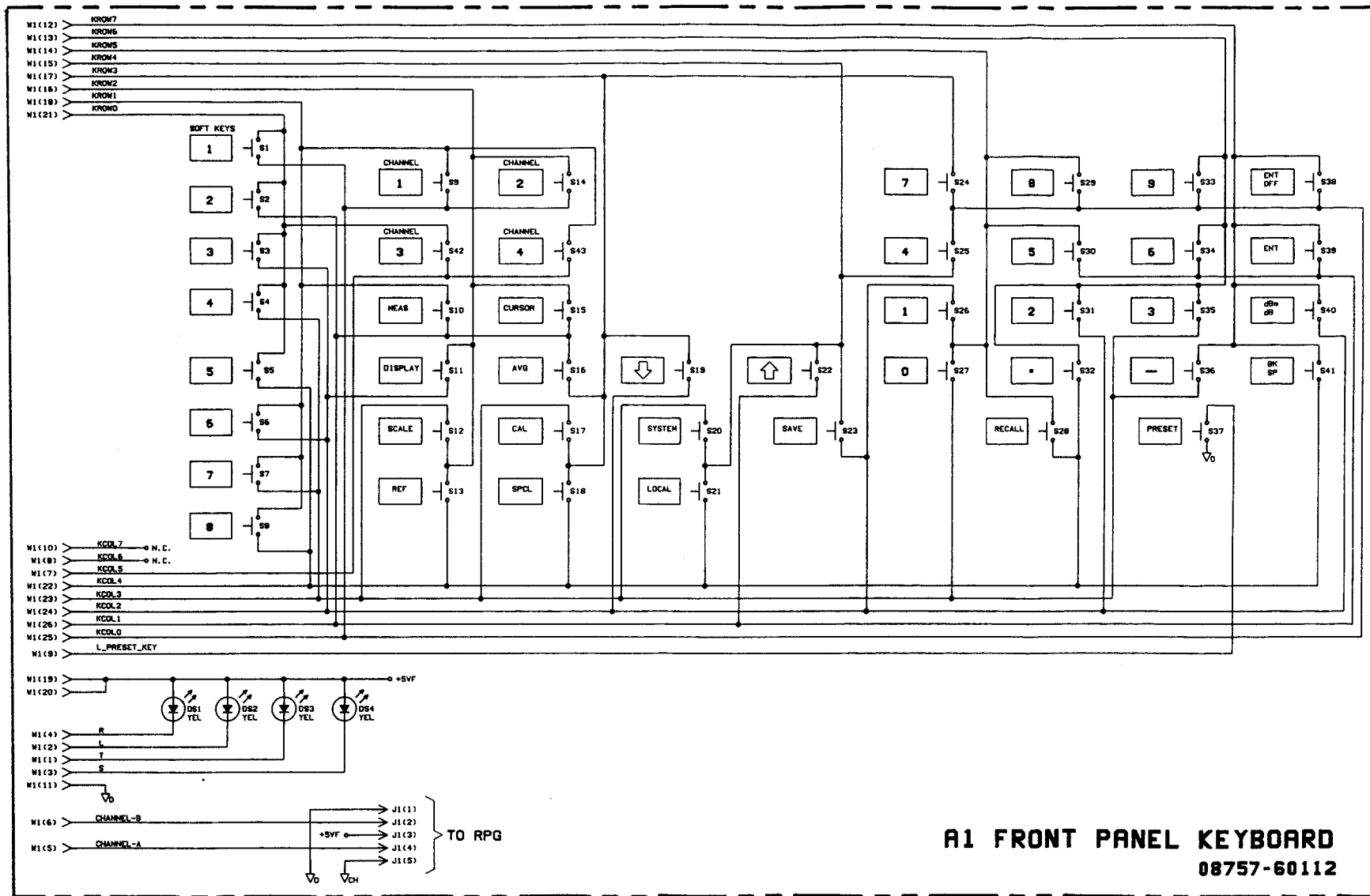


Figure 8-10. A2 Component Locations Diagram



**A1 FRONT PANEL KEYBOARD**  
**08757-60112**

# A14 Display Interface Board

## CIRCUIT DESCRIPTION

This board provides an interface between the CPU board and the raster scan display (color or monochrome). The board receives commands from the CPU. It then executes these commands, drawing images (text and trace) to the display.

The display interface board consists of these primary components:

- Graphics System Processor (GSP) chip.
- 64K words of DRAM (1 word = 16 bits).
- 256K words of Video DRAM (VRAM).
- Memory address decoding logic.
- Pixel processing circuitry.
- Video test circuitry.
- Video Color Palette chip.
- The heart of the display board is the TMS–34010 Graphics System Processor (GSP) chip. This chip is responsible for managing the entire graphics system. It receives graphics drawing commands from the CPU and executes them. It also generates the proper video timing (HSYNC, VSYNC, and BLANK) required by the raster scan display.
- The memory address decoding logic is used to select the proper memory banks and to properly address the memory chips.
- The 64K of DRAM is used to store the GSP's program and data, and to store the list of drawing commands received from the CPU. The 256K of VRAM is used to store the data for 2 screens of video information. The GSP issues special memory commands which instruct the VRAMs to shift out a serial stream of pixels (picture elements).
- The pixel processing circuitry interfaces the pixels coming from the VRAMs to the video color palette chip. It also performs pixel stretching, which widens each pixel to make it more square.
- The video color palette chip accepts pixels from the pixel processing circuitry, converts each pixel into one of 4096 colors, and outputs the analog RGB signals which drive the raster display.
- Due to the complexity of this board, it is not possible to provide a complete description of the theory of operation. Instead a cursory description follows which, together with the troubleshooting techniques, should provide enough information to repair most failures. For those boards in which the problem cannot be isolated, a tested exchange board can be purchased from Hewlett–Packard (see "Replaceable Parts").

### A. CPU INTERFACE

The host 68000 CPU is connected to the GSP via a 34 pin connector (J4). The host interface circuit consists primarily of U11, U12, and U43. U11 and U12 buffer the host data bus between the CPU and the GSP. They are necessary because the GSP must drive the entire instrument bus.

U43 is a registered PAL. Its purpose is to select either the GSP or the intensity/background DAC, depending on the inputs. This PAL is also responsible for generating LDTACK at the proper time, depending on the type of access. DAC accesses take a fixed time, while the GSP accesses take a variable amount of time, determined by the HRDY signal from the GSP.

This PAL also controls the CPU interface timing. Normally the GSP requires some setup and hold time on its address, data, and control inputs. This PAL eliminates these requirements, making the CPU interface timing simpler.

## B. INTENSITY / BACKGROUND CONTROL

Intensity and background levels are controlled by a dual DAC (U10). The CPU writes 8 bit values to it to control brightness and contrast of the display. The DAC is used in a non-standard configuration, making it act like a voltage divider. A 1.0 V reference is supplied to IOUT (pins 2, 20). Then, depending on the DAC setting, a voltage between 0 and 1.0 V will be seen on the VREF inputs (pins 4, 18) of the DAC. U13 buffers the 0 to 1 V output of the DAC, and maintains this voltage on its inverting inputs (pins 2, 6). This voltage causes a current between 0 and 10 mA to flow through the 100 ohm resistors (R14, R15). These current sinks are connected to the intensity and background inputs of the display, respectively. The intensity output is also monitored by the self-test circuitry to verify proper operation. The background output is not monitored since its failure would have only minor cosmetic effects.

## C. GRAPHICS SYSTEM PROCESSOR (GSP)

The GSP (U25) is the heart of the graphics board, controlling all major functions. A 50 MHz crystal oscillator supplies the GSP with its required clock

## D. MEMORY DECODING

Memory address decoding is performed by U28, U47, U49, and U50. Latch U28 is used to generate various signals used in decoding. On a shift-register-transfer cycle, LTR/LQE is latched low, creating LSRT. On a RAM refresh cycle, LAD15 is latched low, creating LRF. LAD14 and LAD13 are latched on LRAS, creating logical addresses A26 and A25. A26 and A25 are used as shown in Table 8-28.

*Table 8-28. Memory Cross-Reference*

A26	A25	Memory Device Selected
0	0	VRAM
0	1	VRAM
1	0	Self-test circuit
1	1	DRAM

LAD1 and LAD0 are latched on LRAS, creating logical addresses A13 and A12. A13 and A12 are used to select one of 4 banks of VRAMs.

NAND gate U45C and delay line U47 are used to delay the LLAL by approximately 24ns, which helps provide more accurate timing to the decode PAL. Delay line U47 is used to delay LLAL by 20 ns. This provides the timing required to select LLE1 and LLE2 at the proper times.

Decode PAL U49 is responsible for supplying the LRAS (Row Address Strobe) signal to the DRAMs and VRAMs. Logical address lines A13 and A12 are used to select one of 4 VRAM banks to supply with RAS. When PAL input LRF goes low, a refresh cycle is signaled, and RAS is sent to all VRAMs and DRAMs.

SRTRD goes high upon a VRAM Shift Register Transfer (SRT) cycle. This cycle signals the VRAMs to transfer one row of memory to their on-board, internal shift registers. SRTRD is used to signal U9 to latch the address of the VRAM bank currently selected for shift output. LLE1 and LLE2 are used to select U40 or U39 while addressing the VRAMs and DRAMs.

Decode PAL U50 is responsible for supplying CAS (Column Address Strobe) to the VRAMs or DRAMs. LCASV supplies the VRAMs with CAS. LRASD and LCASD supply the DRAMs with RAS and CAS.

LSRTWR is used to force the SE input on the VRAMs low during reverse SRT cycles. These cycles are used to clear the screen quickly. LTEST is asserted when reading from the test latch.

U46 and U47 are used to select one of 4 banks of VRAMs to be shifted. The selected bank is then latched, resulting in pixels being sent to the pixel processing circuitry.

LSCLK and HSCLK are the shift clock outputs used to clock the VRAMs. These two outputs are used to gate SCLK to the VRAMs. The VRAMs use SCLK to serially clock out pixels. It is necessary to gate SCLK so that this clocking does not begin until the end of horizontal blanking.

## **E. ADDRESS LATCHING**

Latches U39 and U40 are enabled to supply the proper address to the memories. U38 dampens the signal lines. U39 is always used to supply the memories with their address except when U40 is used. These times include VRAM row address (from GSP column address), VRAM shift address, and DRAM and VRAM refresh address. U40 is used to supply the VRAMs with their column address. This column address is actually the GSP's row address output.

## **F. DRAM**

These four 64K x 4 DRAMs provide 64K words (16-bit words) of storage for the display list and the GSP program.

## **G. VRAM**

This block of sixteen 64K x 4 VRAMs provides 256K words of video memory, equivalent to 1 million 4-bit pixels. Since the screen size is 1024 x 400, this is enough memory to store 2.5 screens of information. This enables the processor to display entirely updated screens instantaneously by displaying one screen while updating another.

## H. PIXEL PROCESSING

When video data is shifted out of the VRAMs, it comes out as 16-bit quantities (four 4-bit pixels in parallel). U15 and U16 are 2:1 multiplexers which break this 16-bit wide video stream into two streams of 4-bit pixels. The video rate of data entering these multiplexers is 9 MHz. The video rate of data leaving is 18 MHz. This is because the total video data path width has been reduced from 16 bits to 8 bits.

Latch U29 saves the value of the previous pixel. This value is used by PAL U14 when it performs pixel stretching. Inputs to this PAL are the two current pixels and the previous pixel. An enable input is also used to turn stretching off while the color table of the palette chip is being loaded (first line of the display which is blanked by the palette).

Flip-flop U30A takes the 18 MHz output of the palette and divides it by 2. The 9 MHz output is called SCLK, and is used to clock both the GSP and the VRAM's serial output. Flip-flop U41A is used to synchronize the GSP's BLANK with SCLK. The Q-output of U41A is used to gate SCLK to the VRAMs. U41B is used to blank the palette output, and is delayed 1 SCLK cycle from the synchronized blank of U41A. This delay is necessary due to the 1 SCLK delay period that it takes a pixel to move through the pixel processing chain.

## J. VIDEO OUTPUT

The video color palette chip U1 performs pixel color look-up and digital to analog conversion. The palette uses video clock U42 to clock analog voltages out. Video clock U42 clocks the palette chip at the video rate of 35.904 MHz. Pixels are clocked into the palette on the rising edge of the palette's CLKOUT signal, which is equal to the DOTCLK video clock input divided by two. Each pixel value that is clocked into the palette is converted into one of 4096 possible RGB values using the internal color look-up table. The resultant analog RGB value is used to drive the RGB display monitor. The voltage range of the analog output of the palette is typically 0.65 V (black) to 2.3 V (white). The resistor dividers on the analog output attenuate the voltage to 49% of its original value. This provides the RGB display with a typical voltage range from 0.3 V to 1.1 V. Since the monitor is AC coupled, it sees a 0.8 V p-p signal. This slightly exceeds what the display expects to see (0.714 V) so that full brightness is guaranteed even under worst case conditions.

Display connector J3 connects to the internal display. It's signals include LVSYNC, LHSYNC, R, G, B, Intensity, Background, +65V and GND. External RGB Monitor Connector J2 supplies raw R, G, B, VSYNC, and HSYNC signals to the rear panel RGB output board (if applicable). The rear panel board buffers them, adds sync on green, and drives an external monitor.

The grounds to these connectors (J2 and J3) are isolated from the board's digital ground via R2, R12, C4, and C10. These components provide a low impedance AC ground path, but not a DC path. This eliminates possible ground loops.

## K. VIDEO SELF-TEST

The self-test circuitry consist of U31 and U33. Comparator U31 compares the Red, Green, Blue, and Intensity DAC signals to a known reference voltage of 0.58 V. If the input is above the reference voltage, the comparator's open-collector output is driven low. Buffer U33 is enabled by the GSP to read the signals being tested.

## **L. POWER SUPPLY FILTERING**

The display interface board requires a +5 V supply only. This is supplied by a separate +5 V regulator on the A12 board. The supply is locally filtered and decoupled by a network of capacitors. A coil is used to prevent AC signals from feeding back into the main power supply.

The +65V and MON GND, along with their associated sense lines, travel across the display interface board to the video connector to provide power to the display. They are not used on the A14 display interface board.

## A14 Adjustments and A14 Diagnostic Tests

The display interface board has several diagnostics for troubleshooting both the A14 interface board and the display.

The diagnostics consists of the following:

- Self-tests that are performed at power up and preset.
- Self-tests and test loops that can be manually selected.
- Test patterns that both verify circuitry, and also allow easy troubleshooting with an oscilloscope.
- Forced diagnostic tests that can be run by setting switches on the A3 CPU board.
- There is no error checking performed on the diagnostic test patterns; it is up to the operator to interpret the results.
- Adjustments consist of the following:
  - Nominal intensity level (100% level).
  - Minimum default intensity.
  - Background intensity.
- The display diagnostics menu can be reached by pressing the following keys:

**PRESET** **SYSTEM** **MORE** (8) **SERVICE** (8) **DISPLAY** (1)

The number in parenthesis indicates the label corresponding to the softkey, where number 1 is the top softkey and number 8 is the bottom softkey. These numbers are given in case a non-functioning display renders the softkey labels unreadable.

### ADJUSTMENTS

The following adjustments are preset at the factory and normally will not need re-adjustment unless the A15 display, the A14 display interface, or the A3 CPU boards are replaced. The user may also wish to customize these adjustments to his environment. If adjustments are made, make the background adjustment first.

#### Background Adjustment

Access the diagnostic menu, then press **BCKGRND ADJUST** (3).

The background adjustment sets the black level of the display. It should be set so that the minimum intensity that can be drawn is just barely visible when the display is located in a dimly lit room (or shaded from bright lights).



When **BCKGRND ADJUST** is pressed, alternating vertical bars of 3 different intensities will be drawn. Each will have a number written below it from 0 to 2. Adjust the RPG until the vertical bar labeled "1" is just barely visible while under low ambient light conditions (but not dark). Vertical bar "0" must not be visible at all. To store the value, press any softkey. Then close switch A3S1–E and press **SAVE VALUE**. Open the switch.

## Nominal Intensity

Access the diagnostic menu, then press **NOMINAL INT ADJ** (1).

The analyzer will display a completely white screen. The RPG (knob) can be turned to adjust the intensity. Using a nit meter, adjust the RPG for an intensity of 100 nits if the glass bezel assembly is *not* installed, or 60 nits if the glass bezel *is* installed (the glass filter transmits 60% of the light). If the specified intensity cannot be reached, set it as close as possible. Once this has been set, press any softkey. The current DAC value will be displayed (0=full intensity, 255=minimum). Close switch A3S1–E and press **SAVE VALUE**, then open the switch. This intensity will now become the 100% setting. Note that all display characteristics are specified at 100 nits. While higher intensities may be available, the quality of the images may be slightly degraded. Higher intensities may also shorten the CRT life if left for extended periods of time. The setting of this adjustment will have no effect on the range of brightness available; it only affects the displayed percentage of brightness.

## Minimum Intensity

Access the diagnostic menu, then press **MINIMUM INT ADJ** (2).

Normally the analyzer will preset (or power on) to the same intensity level that was last used. However, if the last used intensity level was at its minimum, it may not be possible to see the display, thus causing concern as to whether or not it is functioning. To prevent this possibility, the analyzer is set to a default level if the previous level was too low.

The procedure to set this default level is the same as the nominal intensity level procedure above, except for the nit values. For this adjustment, set the default levels to 20 nits if no glass filter is present, or 12 nits if it is present.

## Test Patterns

Test patterns are useful for display adjustments, diagnostics, and troubleshooting. This information is provided for use in all three situations.

To access the test patterns from the display diagnostics menu, press **TEST PATTERN** (4).

The test pattern number below can now be input using the keypad and terminated with the **ENT** key. Alternately, the RPG or step keys can be used to select the test pattern. There are 15 test patterns which are listed in Table 8–29.

*Table 8–29. Test Pattern Summary*

Number	Test Pattern	Number	Test Pattern
1	All White	9	Inverse Crosshatch
2	All Red	10	H Pattern (focus)
3	All Green	11	Pixel Stretching Test
4	All Blue	12	Repeating Gray Scale
5	16–Step Gray Scale	13	Color Rainbow
6	3–Step Gray Scale	14	Character Set
7	Convergence Test	15	Bandwidth Pattern
8	Crosshatch		

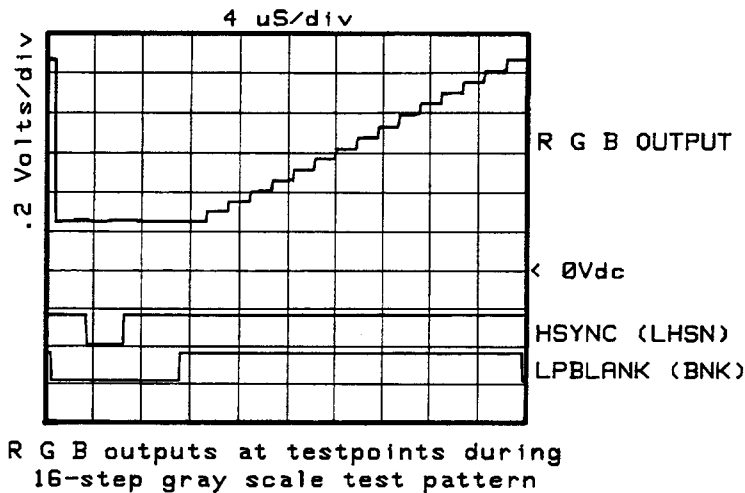
**NOTE:** Test pattern 12 can be forced at preset by closing status switches A3S1A through D. See “Forced Diagnostic Tests.”

The following is a description of the test patterns.

**1. All White.** This pattern is used to verify the light output of the display and to check for color purity. In this, and other solid test patterns, an extremely thin full–screen horizontal line will be seen about 1/4 screen height from the bottom. This condition is characteristic of the CRT and does not indicate any problem.

**2–4. All Red, Green, Blue.** These test patterns verify the color purity of the CRT and also the ability to independently control each gun color. If the purity of the displayed test pattern is a problem, it usually indicates that the face of the CRT needs to be de–gaussed (de–magnetized). If purity is bad, cycling the power a few times may cure the problem. If this does not work, a commercially available de–magnetizer must be used. See instructions and warnings under “A15 DISPLAY”.

**5. 16–Step Gray Scale.** This pattern is used to verify that the palette chip on the A14 board can produce 16 different amplitudes of color (in this case, gray.) This pattern is also very useful when using an oscilloscope for troubleshooting. The staircase pattern it produces will quickly show missing or stuck data bits. A typical palette chip output is shown in Figure 8–40.



*Figure 8-40. 16 Step Gray Scale*

**6. 3-Step Gray Scale.** This pattern consists of the first three gray scale bars of the 16-step gray scale. It is used for adjusting the background level (or 0 step) so that the first bar is not visible, and the second bar is just barely visible.

**7. Convergence Pattern.** This pattern is used when measuring the accuracy of the color convergence. It is mainly for use by the factory, since convergence cannot be adjusted in the field.

**8,9. Crosshatch and Inverse Crosshatch** These patterns are used by the factory to test color convergence, linearity, alignment, and high voltage regulation. No field adjustments are possible.

**10. H Pattern.** This pattern is used to check the focus of the CRT. Under normal conditions, this should never need to be adjusted. However, it is possible to adjust it in the field by accessing the focus control adjustment at the left rear of the A15 display. See "A15 DISPLAY".

**11. Pixel Stretching.** This pattern verifies the functionality of the pixel stretching circuit of the A14 display interface board. Under normal conditions, this pattern should appear all white. If a failure occurs in the pixel stretching circuit, the pattern will consist of 16 alternating white and gray vertical stripes. Suspect problems with with the STRETCH line and LFIRSTPIX.

**12. Repeating Gray Scale.** The repeating gray scale is used for troubleshooting with an oscilloscope. It is similar to the 16 step gray scale but is repeated 32 times across the screen. Each of the 3 outputs of the video palette will then show 32 ramps (instead of one staircase) between each horizontal sync pulse. This pattern is used to troubleshoot the pixel processing circuit of the A14 display interface board. An example of the output is shown in Figure 8-45.

**13. Color Rainbow.** The color rainbow quickly shows the ability of the display interface board to display 15 colors plus white. The numbers written below each bar indicate the tint number used to produce that bar (0 & 100=pure red, 33=pure green, 67=pure blue).

**14. Character Set.** The character set is provided to conveniently show the user all the different types and sizes of characters available. Three sets of characters are drawn in each of the three character sizes. 125 characters of each size are displayed. Characters 0 and 3 cannot be drawn and several others are really control characters (such as carriage return and line feed).

**15. Bandwidth Pattern.** This pattern provides a quick visual verification of the bandwidth of the display. It consists of multiple alternating white and black vertical stripes. Each stripe should be clearly visible. A limited bandwidth would smear these lines together. No field adjustment is possible.

## DIAGNOSTIC TESTS

### Display Test

Access the display diagnostics menu, then press **DISPLAY TEST** (5).

This test verifies the ability of the CPU to write to each of the four registers of the GSP. It writes a different value to each register and then reads them all back. It then writes a walking 1 pattern to one location. Any failure will attempt to be displayed on the CRT, although this may not be possible. This test can be continuously cycled by pressing softkey 2 **CYCLE** and can also be forced to run by closing status switches A3S1-A and A3S1-B on the A3 CPU board. Typical waveforms are shown in Figure 8-41.

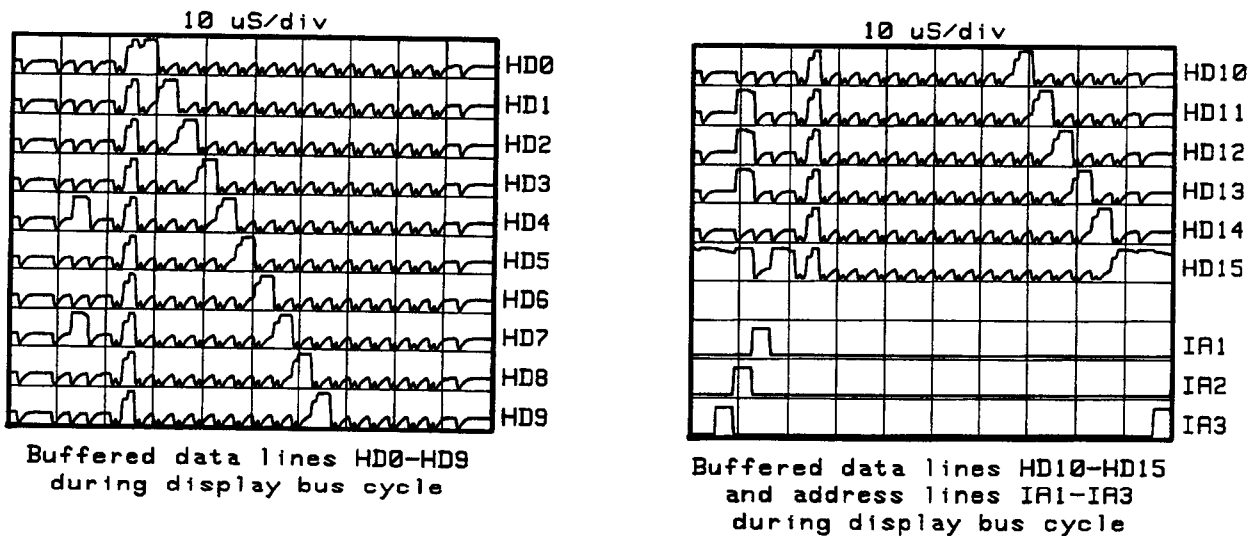


Figure 8-41. Display Cycle

### Background and Intensity Ramps

Access the display diagnostics menu, then press **MORE** (6), then **BCKGRND RAMP** (1) or **INTNSTY RAMP** (3).

Both the background and intensity DACs can be continuously ramped to verify the functionality of the dual DAC (U10). With the display disconnected, a 0–1 V ramp will appear at the appropriate test points (BKGD and INT). With the display connected, a negative ramp from about +8 to +1 V should appear. The actual voltages may vary slightly from unit to unit and the ramp may have some curvature at the transition point due to the input capacitance of the display.

## Other Adjustments

There are only two adjustments that can be made on the display itself. These are focus and vertical centering. Both should seldom, if ever, require adjustment. Focusing should be adjusted while viewing test pattern 10 (the H pattern). See "A15 DISPLAY" for more information.

## FORCED DIAGNOSTIC TESTS

Several A14 tests can be forced to run by closing two or more status switches A3S1A–D on the A3 CPU board. Closing, in this case, means setting the switch toward the left side of the analyzer when viewed from the front. Once set, press **PRESET** or cycle the power. The CPU will immediately run the indicated test. Normal operation will resume only after all switches are opened and **PRESET** is pressed. Table 8–30 shows switch positions for the forced diagnostic tests.

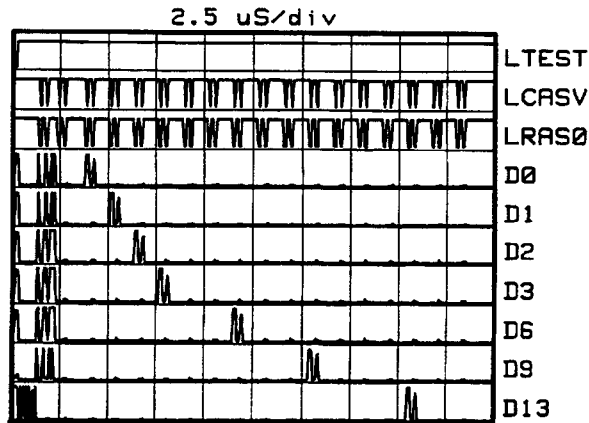
*Table 8–30. Forced Diagnostic Tests*

Test	Switch Positions
Display Bus Cycle	Close switch Chapters A and B
Display Interface DRAM Loop	Close switch Chapters A and D
Display Interface VRAM bank 0 Loop	Close switch Chapters B and D
Display Interface VRAM bank 1 Loop	Close switch Chapters A, B and D
Display Interface VRAM bank 2 Loop	Close switch Chapters C and D
Display Interface VRAM bank 3 Loop	Close switch Chapters A, C and D
VRAM Device Error Indicator	Close switch Chapters B, C and D
Repeating Gray Scale Test Pattern	Close switch Chapters A, B, C and D

The display bus cycle will set up a walking 1 pattern on the buffered data lines to the GSP chip. It also exercises address lines IA1–IA3. A sample output is shown in Figure 8–41. This is the same test as the display test described previously.

The display interface DRAM Loop sets up a walking 1 pattern on the data and address lines of the GSP chip U25. This test is described in detail in "Error Code 9". The data and address lines could be normally high or low. You must look at the lines during the proper transitions of LCAS and LRS to determine the actual output status. See Figure 8–45 for a sample timing diagram.

The display interface VRAM loop (banks 0–3) performs a very similar test to the DRAM loop. The same conditions and precautions as in the DRAM loop, above apply. A sample output of some data lines is shown in Figure 8–42.



1st 2.5  $\mu$ S of VRAM loop showing some data lines. D14 and D15 look very different due to changing VRAM/DRAM status bits.

*Figure 8-42. VRAM Loop*

The VRAM device error indicator test will isolate any VRAM bank failure to a single VRAM, or as many as four, depending upon the type of failure. This test should be performed if *any* VRAM test has failed. To perform this test, close the indicated switches on the A3 CPU board and press **PRESET** or cycle the power. The CPU will perform a test on each of the four banks of VRAM and report any indicated failures via the LEDs on the A3 CPU board. The four most significant bits (DS1; labeled MSB) show which of the four banks of VRAM has failed (only the first failed bank is shown). The least significant bits (LSB) show which VRAMs in each bank have failed (the status of all four VRAMs is shown). A lit LED indicates a failure. Use Table 8-31 to correlate the fail code with the VRAM reference designator. A "1" indicates a lit LED, a "0" indicates an extinguished LED and an "X" is a don't care state.

*Table 8-31. Device Reference Designator Versus VRAM Error Code*

LSB Device Code		MSB Bank Number			
		Bank 3 1000	Bank 2 0100	Bank 1 0010	Bank 0 0001
Bits 0-3	XXX1	U8	U6	U4	U2
Bits 4-7	XX1X	U9	U7	U5	U3
Bits 8-11	X1XX	U23	U21	U19	U17
Bits 12-15	1XXX	U24	U22	U20	U18

Hints on using this VRAM test: If all four LSB LEDs light and the MSB indicates bank 0 is defective, then the problem is most likely a bad control line going to the VRAM (since bank 0 is the first bank tested). Any time an error is indicated in bank 0, suspect the control lines and address/data traces before suspecting the individual VRAMs. This test is very useful in isolating problems that generate error code 5 or 6.

The repeating gray scale test is useful for testing the pixel processing portion of the board. Bit patterns during this test produce easily identifiable waveforms that can be used to troubleshoot to the component. Typical outputs are shown in Figure 8–45.

## A14 Troubleshooting

### WARNING

**+65 V lines run from J1 to J3 on the A14 display interface. Do not contact these traces or personal injury may result.**

**NOTE:** For troubleshooting purposes, the A14 display interface board can be removed from its holder and placed on the rear frame of the analyzer chassis. First disconnect all cables. Place a piece of non-conducting material under the board to prevent shorts to chassis ground. Orient the board, component side up, with the cable connections facing the front of the analyzer. Reconnect all cables to the board.

The A14 display interface board incorporates several self-tests to insure proper operation and to aid troubleshooting. Most of these self-tests are performed during preset and all are performed at power on. Results of these self-tests are displayed on the four front panel LEDs and are duplicated on the A3 CPU board. Additional error analysis is presented by four additional LEDs on the A3 CPU board.

The self-tests verify numerous portions of the board and actually check for reasonably proper operation at the RGB outputs of the board. However, on a board this complex, it is not possible to test for all conceivable failures. It is possible for some failures to occur, yet not be caught by the self-tests. If existence of a problem is questionable in the A14 display interface or the A15 display, the easiest troubleshooting approach is to either connect a compatible display to the external RGB outputs on the rear panel or to substitute another internal display. If all self-tests pass, the RGB and sync signal look good, but the display is blank, missing colors, or distorted; the problem is most likely in the A15 display itself.

The following information should be noted when troubleshooting the display interface board:

- The horizontal scan frequency is 25.5 kHz (a period of 39.216 ms).
- The vertical scan rate is 60 Hz (a period of 16.67 ms).
- The number of horizontal pixels is 1024.
- The number of horizontal lines is 425 (only 400 are actually displayed).
- A new pixel is drawn every 55.7 ns.

### BASIC CHECKS

Verify all cables are connected properly. Verify the +5 V power supply is present at TP3 (+5V). Verify the +65 V power supply is present (within  $\pm 0.4$  V) at pins 2, 4, and 6 of J3. A voltage slightly exceeding 65.4 V probably indicates an open line to the display. Verify 50 MHz and 35.904 MHz at TP14 (50MHz) and TP7 (PCLK) respectively. If DS1 is lit, it indicates that much of the display interface is working.



## ERROR CODE DESCRIPTION

During self-test all eight CPU error code LEDs (A3DS1–2) and the HALT LED (A3DS3) should light briefly and then go out. If any of the LEDs do not extinguish, the lit ones indicate an error code in 8–4–2–1 binary (viewed from the component side, left to right). The left hand LEDs indicate a primary error code and this pattern is repeated on the front panel if possible. The four LEDs on the right indicate a sub error code which gives more specific error analysis. The sub error code is bit specific; each lit LED represents a particular failure. For example: a sub error code of 0001 (the far right LED only is lit) indicates a specific failure. A sub error code of 0010 indicates a different failure. A sub error code of 0011 indicates the combination of the two failures. Sub error code listings will show examples such as XX1X, where X represents a don't care state and the "1" indicates the specific LED that is lit; representing a specific failure. The following error codes generally relate only to the A14 display interface board.

### 1010 (Error Code 10) —Display Interface Failure

**Sub Error Code XXX1 —All Bits =0 or**

**Sub Error Code XX1X —All Bits =1 or**

**Sub Error Code X1XX —Walking 1 Pattern or**

**Sub Error Code 1XXX —GSP Register Address.** This error code indicates that the CPU board cannot communicate with the four registers contained within the GSP chip on the display interface board. The CPU tries to write all zeros, all ones, and then a walking 1 pattern to the GSP and read them back. It then writes to all four GSP registers and verifies each register can be accessed independently.

Since this is the first error code associated with the A14 board, it may simply indicate that the interface cable is not connected or the display 5 V supply is missing. In this case the fail code for All bits=1 should not be lit since normally the data bus will float high if nothing is driving it. A sub error code of 1XXX could indicate an open IA1 or IA2 line. Other common problems with error code 10 could be the lack of a 50 MHz clock input or lack of the 18 MHz clock that is derived from the 35.904 MHz oscillator.

If this test fails, the CPU will continuously repeat the test until it passes. This places a known pattern on the signal lines and allows the user to troubleshoot by checking for these known signal patterns. An example of the expected signals are shown in Figure 8–41. Verify all data bits and address lines IA1–IA3 are functioning properly up to the GSP chip U25.

### 1001 (Error Code 9) —Display Interface DRAM Failure

**Sub Error Code XXX1 —All Bits =0 or**

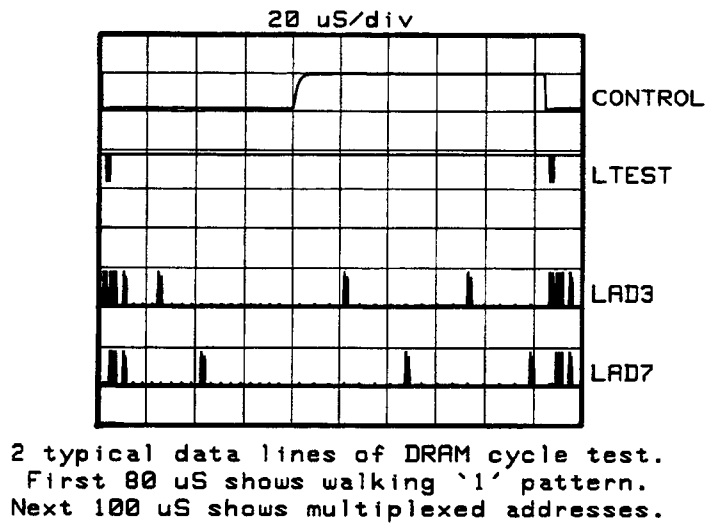
**Sub Error Code XX1X —All Bits =1 or**

**Sub Error Code X1XX —Walking 1 Pattern or**

**Sub Error Code 1XXX —Addressing.** Upon passing error code 10, the CPU has verified that it can communicate with the GSP chip. It now tries to write a data pattern to DRAM and read it back. As in other tests, it writes all zeros, ones, and then a walking 1 pattern and then reports any errors. After it has done this at one location of DRAM, it tests each address line by writing a number to each of 16 addresses (DRAM address 0, 1, 2, 4, 8, 16 etc.). Since only 8 address lines go to each DRAM, the address lines are multiplexed; first the most significant address byte is sent, then the least. This essentially performs a dual walking 1 pattern on the address lines. Any deviation in the expected data is reported as an address error (sub error code 1XXX).

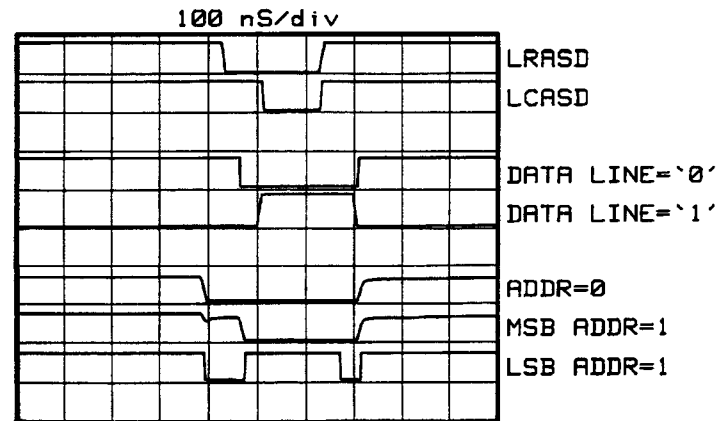
Failures in this test could be the result of several causes. Most likely causes would be the failure of PALs U49 and U50, U39, U28, the GSP chip U25, and the DRAM itself U34–37.

Troubleshooting this loop is best performed by forcing the GSP DRAM loop test by closing A3 switch A3S1–A and A3S1–D, then pressing **PRESET**. This will continuously loop the series of the walking 1 and dual walking 1 patterns. Total loop time is 180 ms with the first 80 ms devoted to the walking 1 pattern on the data lines (18 steps) and the last 100 ms devoted to the address line walking 1 pattern (16 steps). To allow for easy scope triggering, the CPU begins the test by reading from the self-test latch, thus providing a negative going trigger pulse at U33 pin 1 (LTEST). See Figure 8–43.



*Figure 8–43. DRAM Cycle Test*

Checking for the proper waveforms in this test is difficult. Look for a double pulse walking 1 pattern along the 16 data lines during the first 80 ms after the LTEST trigger (one pulse during a write cycle and one during a read cycle). Lack of a double pulse could indicate that a DRAM is not reading or writing properly. In many cases, the double pulse pattern may be obscured by a near constant 6.25 MHz “oscillation”. In other cases, the trace may be normally high instead of normally low as shown in Figure 8–43. In these cases, it will be necessary to carefully view each walking 1 pulse by triggering on LRASD (which goes low for each write/read cycle) and simultaneously viewing the data lines. This will involve the delay triggering mode of many oscilloscopes. The data line is valid during the rising edge of LRASD. A sample waveform showing one write/read cycle for both a “0” and a “1” is shown in Figure 8–44.



Typical data and address lines during DRAM walking '1' pattern relative to LRASD and LCASD

*Figure 8-44. DRAM Walking 1 Pattern*

The address portion of the test is similar to that above except it will show two double pulse patterns during the 16 step cycle instead of one. This is because the DRAMs have 16 bits of addressing and only 8 data input pins; necessitating the multiplexing of the most significant address byte with the least. During this part of the 16 step cycle, the observer should see a double pulse walking 1 pattern roughly coinciding with the negative edge of LRASD for each write/read cycle. The two double pulses will be spaced apart by eight steps. Thus, if a logic one is found on the first step (for address 0) there will also be another one (though slightly narrower) at step 9 (1+8). See the sample in Figure 8-44. These signals may also have a superimposed 6.25 MHz signal on some address lines.

## 1000 (Error Code 8) —DRAM Download Failure

**Sub Error Code XXX1 —Display List Read.** The DRAM has been partially verified. The CPU now sets the GSP into an auto increment mode where an internal counter increments each time DRAM is read. The CPU then reads the DRAM 32768 times and verifies that the counter equals 32768. Any discrepancy is reported. Although unlikely, it could fail if a long display interface cable is used or if there is excessive noise on the power supply or ground. Also suspect the GSP chip itself and even the A3 CPU board. This test does *not* check any of the DRAM.

### Sub Error Code XX1X —GSP Test Load or

**Sub Error Code X1XX —GSP Internal Failure.** The CPU downloads subsequent self-tests to DRAM and lets the GSP chip run the tests. This is done because the GSP has more control over timing of signals and is much faster than the CPU. After the CPU downloads the program, it immediately reads it back. Any discrepancies between what was written and what is read back are reported as a test load failure. The GSP is then instructed to run this code from DRAM. If the CPU determines this test is not being run, it reports a GSP internal failure.

Failures of this type could indicate a problem with the DRAM itself or its associated control lines. Suspect U34–37, U50, and U25.

### **0111 (Error Code 7) —DRAM Cell Test**

**Sub Error Code XXX1 —Bits 0–3 (U37) or**

**Sub Error Code XX1X —Bits 4–7 (U36) or**

**Sub Error Code X1XX —Bits 8–11 (U35) or**

**Sub Error Code 1XXX —Bits 12–15 (U34).** The GSP performs a test on each internal location of DRAM (previous tests only verified a few locations involving each of the 8 address lines). Any failures are reported using the sub error codes. Since all address, data, and control lines to the DRAM have already been verified, the sub error code should correctly indicate the failed component.

### **0110 (Error Code 6) —VRAM**

**Sub Error Code XXX1 —All Bits =0 or**

**Sub Error Code XX1X —All Bits =1 or**

**Sub Error Code X1XX —Walking 1 Pattern or**

**Sub Error Code 1XXX —Addressing.** The GSP now tries to write a data pattern to VRAM and read it back. As in other tests it writes all zeros, all ones and then a walking 1 pattern and reports any errors. After it has done this at one location of VRAM, it tests each address line by writing a number to each of 16 addresses (VRAM address 0, 1, 2, 4, 8, 16 etc.) Since only 8 address lines go to each VRAM, the address lines are multiplexed; first the most significant address byte is sent, then the least. This essentially performs a walking 1 pattern on the address lines. This is repeated for all four VRAM banks. Any deviation in the expected data is reported as an address error (sub error code 1XXX).

Since the address and data lines have been checked with the DRAM tests, and assuming there are no open traces between VRAMs, the most likely causes of failures would be related to those lines associated only with VRAM: LCASV and LRAS0, 1, 2, and 3.

The first step in troubleshooting this error code should be the performance of the VRAM device error indicator (a forced diagnostic test already described.) In many cases this test will immediately isolate the problem to the defective component. If not, it will at least provide more failure information that can be used in conjunction with the VRAM bank loop described earlier.

### **0101 (Error Code 5) —VRAM Cell Test**

**NOTE:** This test is only performed upon power up and instrument verify.

**Sub Error Code XXX1 —VRAM Bank 0 (U2, 3, 17, 18) or**

**Sub Error Code XX1X —VRAM Bank 1 (U4, 5, 19, 20) or**

**Sub Error Code X1XX —VRAM Bank 2 (U6, 7, 21, 22) or**

**Sub Error Code 1XXX —VRAM Bank 3 (U8, 9, 23, 24).** Once the GSP has determined that it can write to VRAM, a complete cell test is performed that verifies each location of VRAM. Since this test takes about one second, it is not performed during preset; only at power on and instrument verify. The sub error codes should isolate any bad cell to a particular data bank (one of four parts). For further isolation to the component level, perform the forced diagnostic test (14); VRAM device error indicator test described earlier.

## 0100 (Error Code 4) —Video Control

**Sub Error Code XXX1 —VRAM Shift.** This sub error code indicates a failure in the ability of the VRAM to internally shift data within each VRAM. This fail code could indicate an internal failure of any of the 16 VRAMs. It is not possible to isolate this problem to any particular device.

**Sub Error Code XX1X —Horizontal Sync or**

**Sub Error Code X1XX —Vertical Sync or**

**Sub Error Code 1XXX —Blank (LPBLANK).** These error codes indicate a failure in the indicated lines. Either the line is not high when it is expected or it is not low when it is expected. The horizontal and vertical sync signals go directly to the display via J3. LPBLANK is a critical signal that, if missing, will prevent the display from operating. The sync signals originate at the GSP chip, but are connected to a few other locations. Should any fail, ensure that there are no shorts pulling the line down. If there are no shorts, suspect the GSP chip. LPBLANK is a slightly delayed (about 220 ns) version of LBLANK which also originates from the GSP chip.

## 0011 (Error Code 3) —R,G,B

**Sub Error Code XXX1 —Red or**

**Sub Error Code XX1X —Green or**

**Sub Error Code X1XX —Blue.** This error code verifies the ability of the indicated signal to toggle above and below a set voltage. The R, G, and B signals are checked at the output of the board. The expected output voltages range from 0.3 V, when the palette chip is set to minimum, to 1.1 V when the pallet chip is set to maximum. This self-test compares this output to a fixed voltage of 0.58 V. The palette chip is set to both minimum and maximum output levels and the state of the comparator is checked each time. These tests verify that at least some video output should be visible on the display.

Failure of any one color probably indicates a failure in the video palette chip U1. Failures of more than one color may indicate a problem anywhere in the pixel processing portion of the board or in the serial output portion of the VRAM and its associated control lines (LSE0–3, SD0–15 etc.) Also suspect U50, U47 and U46. Troubleshooting is best done by forcing the repeating gray scale test pattern (closing A3S1A–D) and comparing the waveforms with those shown in Figure 8–45.

**Sub Error Code 1XXX —Intensity DAC.** The expected intensity DAC output ranges from 0 to 1 V at the emitter of Q2. Both minimum and maximum output levels are checked against the 0.58 V reference. Any errors are reported. Troubleshoot this by ramping the intensity DAC as described previously. Verify a monotonic 0–1 volt ramp at the emitter of Q2.

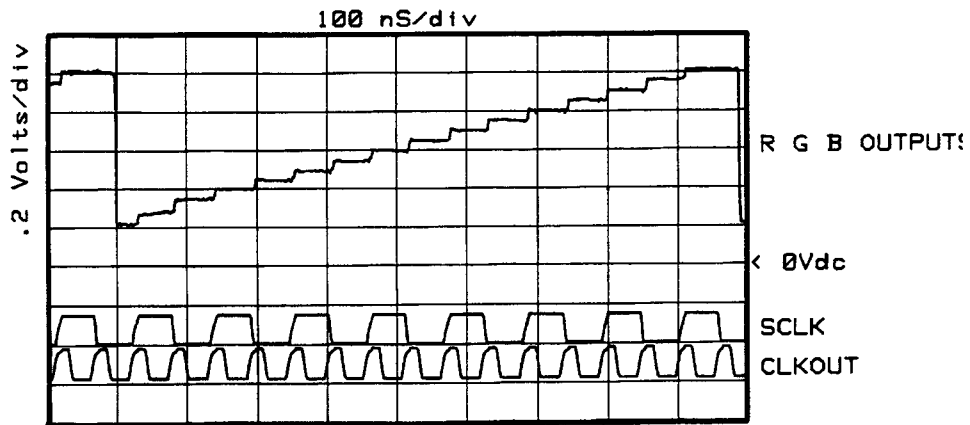
## 0010 (Error Code 2) —INTERRUPT

**Sub Error Code X1XX —GSP Interrupt Fail.** While most of this test is associated with only the A3 CPU board, this one test is related to the A14 display interface board. The GSP is set to send an interrupt. If no interrupt is found this error will result. Suspect the GSP chip itself or an open trace between the display interface board and the CPU board.

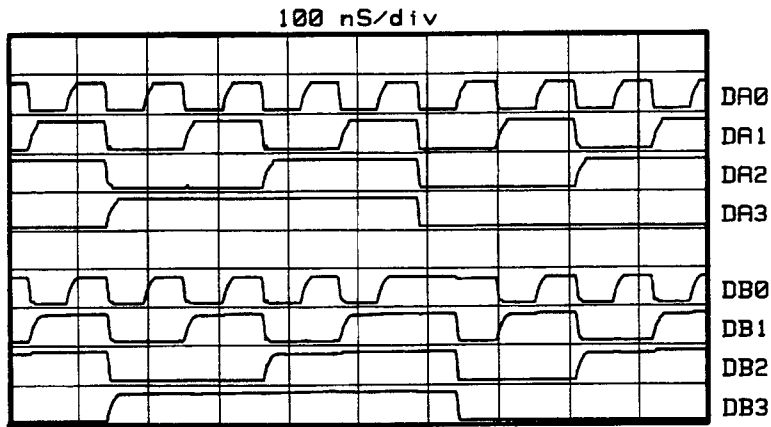
## **No Error Code; But a Distorted, Blank, or Otherwise Incorrect Display**

If no error code is generated, but the CRT shows an incorrect display, then it must first be determined if the problem is with the display or the display interface board. Usually this is easy to determine just by looking at the display. Lack of vertical or horizontal sync even though the signals are present, indicates a failed display. A missing color even though no error code was generated also indicates a failed display. The best method to determine the source of the problem is to substitute a known good display, either directly or via the external R, G, B outputs.

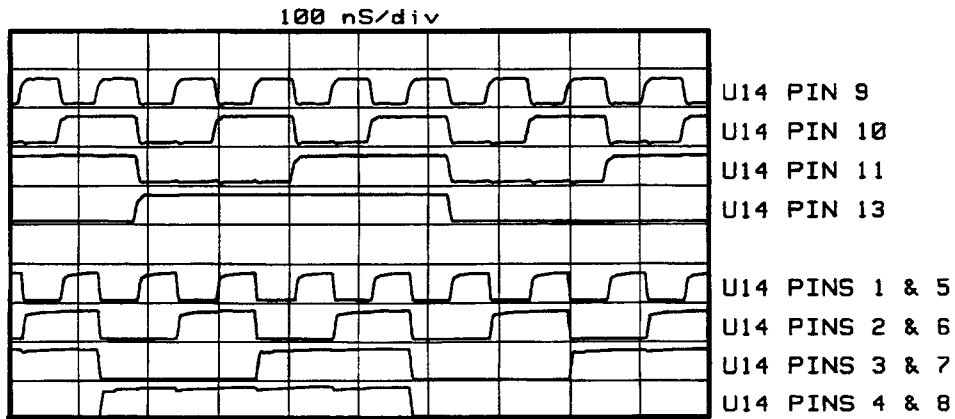
If the problem is not in the display itself, or the connecting cables, then it is probably in the display interface board. Troubleshoot this as if it were an error code 3. Force the repeating gray scale pattern and troubleshoot backwards from the video palette chip using the waveforms in Figure 8–45 as a guide. If all else fails, the board can be exchanged for a previously tested rebuilt board.



Video palette output at testpoints during repeating gray scale pattern.



Video palette inputs during repeating gray scale. Note the six clock cycle delay from input to R G or B output.



Inputs to U14 during repeating gray scale

Figure 8-45. Repeating Gray Scale





**Table 8–32. A14 Pin Outs (1 of 3)**

***A14J1 Pinouts (Power Supply Input)***

<b>J1 PIN</b>	<b>SIGNAL</b>	<b>I/O</b>	<b>FUNCTION BLOCK</b>
1	+65V	I	L
2	+65V SENSE	O	L
3	MON GND	I	L
4	MON GND SENSE	O	L
5	+5V DSP	I	L
6	+5V DSP	I	L
7	DIG GND	I	L
8	DIG GND	I	L
9	N.C.		
10	N.C.		

***A14J2 Pinouts (RGB Outputs)***

<b>J2 PIN</b>	<b>SIGNAL</b>	<b>I/O</b>	<b>FUNCTION BLOCK</b>
1	A GND	O	K
2	BLUE VIDEO	O	K
3	A GND	O	K
4	GREEN VIDEO	O	K
5	LRPSENSE	I	H
6	RED VIDEO	O	K
7	+5VF	O	L
8	LVSYNC	O	C
9	LHSYNC	O	C
10	A GND	O	K

**Table 8–32. A14 Pin Outs (2 of 3)**

**A14J3 Pinouts (Display Output)**

<b>J3 PIN</b>	<b>SIGNAL</b>	<b>I/O</b>	<b>FUNCTION BLOCK</b>
1	MON GND SENSE	I	L
2	+65 SENSE	I	L
3	MON GND	O	L
4	+65V	O	L
5	MON GND	O	L
6	+65V	O	L
7	INTEN	O	B
8	BACKGND	O	B
9	A GND	O	K
10	LVSYNC	O	C
11	A GND	O	K
12	LHSYNC	O	C
13	A GND	O	K
14	A GND	O	K
15	RED VIDEO	O	K
16	A GNDK	O	K
17	GREEN VIDEO	O	K
18	A GND	O	K
19	BLUE VIDEO	O	K
20	A GND	O	K

**Table 8–32. A14 Pin Outs (3 of 3)**

**A14J4 Pinouts (Display Interface)**

<b>J4 PIN</b>	<b>SIGNAL</b>	<b>I/O</b>	<b>FUNCTION BLOCK</b>
1	GND	I	L
2	GND	I	L
3	ID14	I/O	A
4	ID15	I/O	A
5	ID12	I/O	A
6	ID13	I/O	A
7	ID10	I/O	A
8	ID11	I/O	A
9	ID8	I/O	A
10	ID9	I/O	A
11	GND	I	L
12	GND	I	L
13	OD6	I/O	A
14	ID7	I/O	A
15	ID4	I/O	A
16	ID5	I/O	A
17	OD2	I/O	A
18	ID3	I/O	A
19	ID0	I/O	A
20	ID1	I/O	A
21	GND	I	L
22	GND	I	L
23	IA2	I	C
24	IA3	I	A
25	RD/LWR	I	A
26	IA1	I	A
27	GND	I	L
28	GND	I	L
29	LDISPACK	O	A
30	LDISP	I	A
31	LDISPINT	O	C
32	LRESET	I	C
33	GND	I	L
34	GND	I	L

**Replaceable Parts List for A14 Assembly (1 of 2)**

Reference Designation	HP Part Number	Qty	Description	Mfr Code	Mfr Part Number
A14	08757-60065	1	BD AY-GRAPH PROC	28480	08757-60065
A14C1-c3	0160-4835	1	CAP-FXD 0.1uF ±10% 50 V CER X7R	02010	SA105C104KAAH
A14C4	0160-3878	1	CAP-FXD 1000pF ±20% 100 V CER X7R	02010	SR201C102MAAH
A14C5 - C9	0160-4835	5	CAP-FXD 0.1uF ±10% 50 V CER X7R	02010	SA105C104KAAH
A14C10	0160-3878	1	CAP-FXD 1000pF ±20% 100 V CER X7R	02010	SR201C102MAAH
A14C11	0180-3849	1	CAP-FXD 47uF ±10% 10 V TA	04200	299D476X9010DB1
A14C12-C13	0160-4832	1	CAP-FXD 0.01uF ±10% 100 V CER X7R	02010	SA101C103KAAH
A14C14 - C18	0160-4835	5	CAP-FXD 0.1uF ±10% 50 V CER X7R	02010	SA105C104KAAH
A14C19	0180-3771	1	CAP-FXD 1uF ±10% 35 V TA	04200	299D105X9035AB1
A14C20	0160-4832	1	CAP-FXD 0.01uF ±10% 100 V CER X7R	02010	SA101C103KAAH
A14C21	0160-4835	1	CAP-FXD 0.1uF ±10% 50 V CER X7R	02010	SA105C104KAAH
A14C22	0180-3845	1	CAP-FXD 4.7uF ±10% 35 V TA	04200	299D475X9035CB1
A14C23 - C26	0160-4835	4	CAP-FXD 0.1uF ±10% 50 V CER X7R	02010	SA105C104KAAH
A14C27	0180-3771	1	CAP-FXD 1uF ±10% 35 V TA	04200	299D105X9035AB1
A14C28-C29	0160-4832	1	CAP-FXD 0.01uF ±10% 100 V CER X7R	02010	SA101C103KAAH
A14C30-C31	0160-4835	1	CAP-FXD 0.1uF ±10% 50 V CER X7R	02010	SA105C104KAAH
A14C32	0180-3833	1	CAP-FXD 22uF ±10% 10 V TA	04200	299D226X9010CB1
A14C33	0160-4835	1	CAP-FXD 0.1uF ±10% 50 V CER X7R	02010	SA105C104KAAH
A14DS1	1990-0485	1	LED-LAMP LUM-INT=2MCD IF=30MA-MAX BVR=5V	01542	HLMP-1503
A14J1	1252-2365	1	CONN-POST TYPE .100-PIN-SPCG 10-CONT	02946	78207-110
A14J2	1252-1920	1	CONN-POST TYPE .100-PIN-SPCG 10-CONT	04726	2510-5002UB
A14J3	1251-8473	1	CONN-POST TYPE .100-PIN-SPCG 20-CONT	04726	2520-5002UB
A14J4	1251-8474	1	CONN-POST TYPE .100-PIN-SPCG 34-CONT	04726	2534-5002UB
A14L1	08503-80001	1	COIL TOROID		
A14Q1-Q2	1854-1028	1	TRANSISTOR NPN SI TO-92 PD=625MW	02037	2N3904
A14R1	0757-0280	1	RESISTOR 1K ±1% .125W TF TC=0±100	05524	
A14R2	0757-0346	1	RESISTOR 10 ±1% .125W TF TC=0±100	05524	
A14R3	0698-7191	1	RESISTOR 13.3 ±1% .05W TF TC=0±100	05524	
A14R4	0698-7214	1	RESISTOR 121 ±1% .05W TF TC=0±100	05524	
A14R5-R6	0698-7205	1	RESISTOR 51.1 ±1% .05W TF TC=0±100	05524	
A14R7	0698-7205	1	RESISTOR 51.1 ±1% .05W TF TC=0±100	05524	
A14R8	0698-7191	1	RESISTOR 13.3 ±1% .05W TF TC=0±100	05524	
A14R9	0698-7214	1	RESISTOR 121 ±1% .05W TF TC=0±100	05524	
A14R10	0698-7191	1	RESISTOR 13.3 ±1% .05W TF TC=0±100	05524	
A14R11	0698-7214	1	RESISTOR 121 ±1% .05W TF TC=0±100	05524	
A14R12	0757-0346	1	RESISTOR 10 ±1% .125W TF TC=0±100	05524	
A14R13-R15	0757-0401	1	RESISTOR 100 ±1% .125W TF TC=0±100	05524	
A14R16	0757-0418	1	RESISTOR 619 ±1% .125W TF TC=0±100	05524	
A14R17	0757-0405	1	RESISTOR 162 ±1% .125W TF TC=0±100	05524	
A14R18	0698-3446	1	RESISTOR 383 ±1% .125W TF TC=0±100	05524	
A14R19	0698-7252	1	RESISTOR 4.64K ±1% .05W TF TC=0±100	05524	
A14TP1 - TP16	0360-0535	16	CONNECTOR-SGL CONT TML-TS-PT	13296	
A14U1	1820-5897	1	IC-INTERFACE MISC-DGTL MISC/UNKNOWN	01698	TMS34070NL
A14U2-U9	1818-4109	1	64KX4 120 NS P-ZIP SER/RNDM 5V	08779	M5M4C264AL-12
A14U10	1826-1204	1	D/A 8-BIT 20-PLASTIC CMOS	03285	AD7528JN
A14U11-U12	1820-3121	1	IC TRANSCEIVER TTL/ALS BUS OCTL	01698	SN74ALS245AN
A14U13	1826-0346	1	IC OP AMP GP DUAL 8 PIN DIP-P	03406	LM358N
A14U14	5180-8486	1	PAL-PIXEL PROC.		
A14U15-U16	1820-2654	1	IC MUXR/DATA-SEL TTL/F 2-TO-1-LINE QUAD	02910	74F157AN
A14U17 - U24	1818-4109	8	64KX4 120 NS P-ZIP SER/RNDM 5V	08779	M5M4C264AL-12
A14U25	1820-6081	1	IC-32-BIT GRAPHICS SYSTEM PROCESSOR	01698	TMS34010FNL-50

**Replaceable Parts List for A14 Assembly (2 of 2)**

Reference Designation	HP Part Number	Qty	Description	Mfr Code	Mfr Part Number
A14U26	1813-0537	1	CLOCK-OSCILLATOR-XTAL 50.00-MHZ 0.05%	01417	HS-509-50MHZ
A14U27	1810-0205	1	NETWORK-RES 8-SIP 4.7K OHM X 7	02483	750-81
A14U28	1820-3378	1	IC LCH TTL/ALS TRANSPARENT OCTL	03406	DM74ALS373N
A14U29	1820-3318	1	IC FF TTL/ALS D-TYPE POS-EDGE-TRIG COM	01698	SN74ALS273N
A14U30	1820-2691	1	IC FF TTL/F D-TYPE POS-EDGE-TRIG	02910	74F74N
A14U31	1826-0138	1	IC COMPARATOR GP QUAD 14 PIN DIP-P	03406	LM339N
A14U32	1810-0205	1	NETWORK-RES 8-SIP 4.7K OHM X 7	02483	750-81
A14U33	1820-3378	1	IC LCH TTL/ALS TRANSPARENT OCTL	03406	DM74ALS373N
A14U34 - U37	1818-3538	4	DRAM 64KX4 150 NS PLSTC 5V	00039	UPD41464C-15/D41464C-15(or-12)
A14U38	1810-0533	1	NETWORK-RES 16-DIP 33.0 OHM X 8	02483	761-3-R33
A14U39-U40	1820-7296	1	IC LCH BICMOS/BCT TRANSPARENT OCTL 8-BIT	01698	SN74BCT373N
A14U41	1820-2488	1	IC FF TTL/ALS D-TYPE POS-EDGE-TRIG	01698	SN74ALS74AN
A14U42	1813-0484	1	CLOCK-OSCILLATOR-XTAL 35.904-MHZ 0.01%	01417	HS-100-35.904MHZ
A14U43	5180-8487	1	PAL - DISP ACK		
A14U44	1810-1175	1	DELAY LINE ACTIVE DEVICE W/DUAL IN-LINE	12186	DS1000-100
A14U45	1820-2684	1	IC GATE TTL/F NAND QUAD 2-INP	02910	74F00N
A14U46	1820-3100	1	IC DCDR TTL/ALS BIN 3-TO-8-LINE 3-INP	01698	SN74ALS138N
A14U47	1820-2696	1	IC FF TTL/F D-TYPE POS-EDGE-TRIG COM CLK	02910	74F175N
A14U48	1810-0533	1	NETWORK-RES 16-DIP 33.0 OHM X 8	02483	761-3-R33
A14U49	5180-8488	1	PAL - RAS		
A14U50	5180-8485	1	PAL - CAS		
A14W1-W2	1258-0141	1	JUMPER-REMOVABLE FOR 0.025 IN SQ PINS	02946	65474-004
A14X1	1251-5639	2	CONN-POST TYPE .100-PIN-SPCG 2-CONT	02946	68001-602
A14X3	1200-1274	1	SOCKET-IC-CHP-CARR 68-CONT SQUARE	01380	3-821574-1

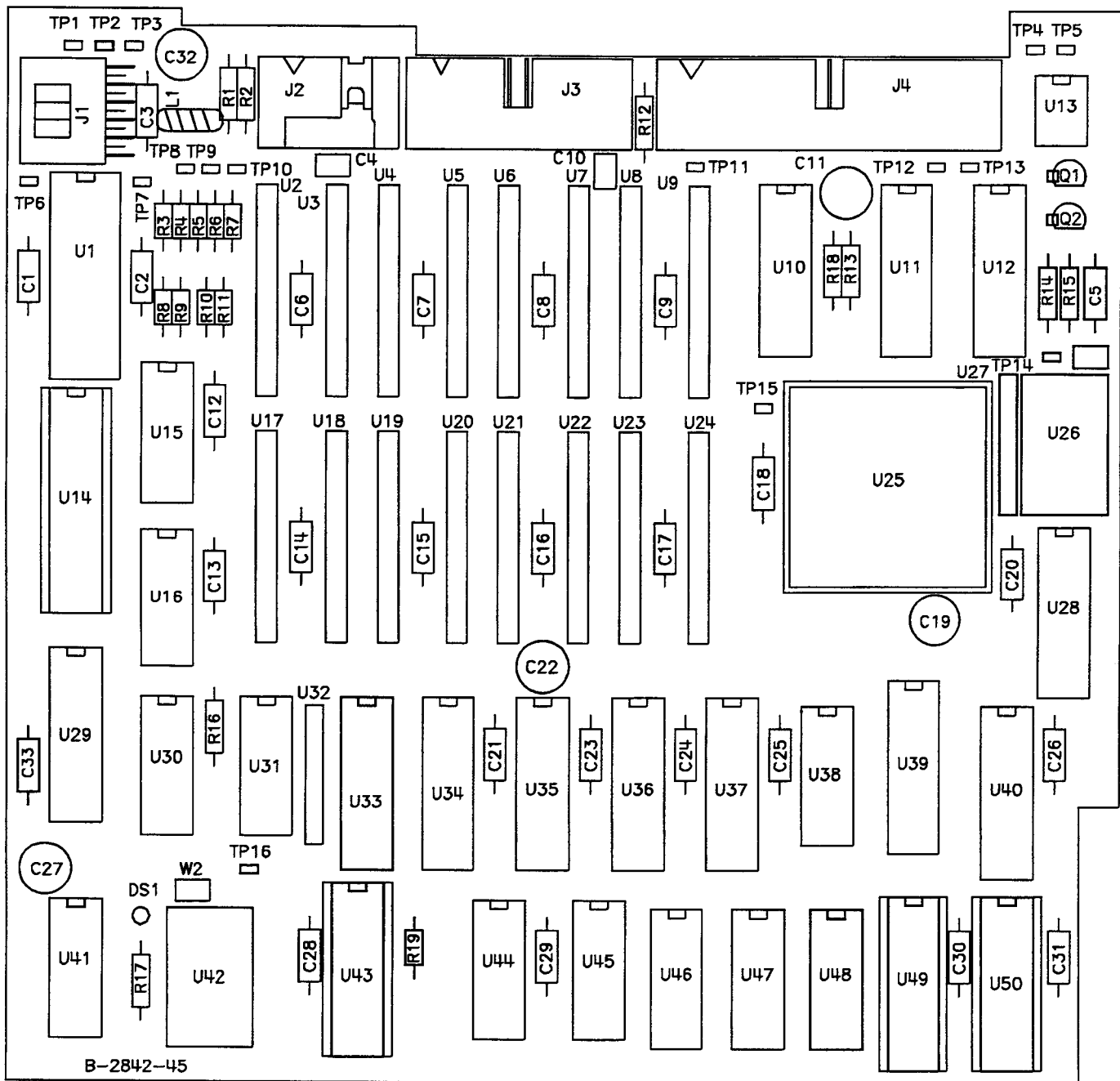


Figure 8-46. A14 Component Locations Diagram

## A15 Display

### DESCRIPTION

The A15 display incorporates a 7.5 inch raster scan CRT along with associated drive circuitry. The display is a self-contained unit. No field repair of the display is possible and no technical documentation is provided. Instead, the display is set up on Hewlett-Packard's exchange program. Should any problem arise, the display can be quickly exchanged for a tested, rebuilt unit. See "Restored Exchange Assemblies" in "Replaceable Parts". The information that follows is provided to help isolate any problems to the A15 display itself or some other assembly.

The display is a raster scan display with a horizontal scan rate of 25.5 kHz. The vertical scan rate is 60 Hz. The A14 display interface provides 425 horizontal scan lines although only 400 are actually displayed. Inputs to the display include digital TTL horizontal and vertical sync signals; red, green and blue (RGB) video signals; intensity and background signals; and a +65 V power supply. The expected video signal levels for the RGB inputs are the following: 0.7 V<sub>p-p</sub> video; 0.3 V =black; 1V =white. The video input to the display is first terminated in 75 ohms and then AC coupled to the display circuitry so that DC offsets are blocked. Under nominal conditions the typical video drive signal is actually 0.8 V<sub>p-p</sub>, thus providing a guarantee that full brightness can be achieved. To eliminate any magnetization of the CRT, automatic degaussing is enabled each time the instrument is turned on.

## A15 Troubleshooting

If the display appears defective, the source of the problem should be verified before exchanging the display. This can be done three ways:

1. Connect an external compatible display to the rear panel R, G, B outputs to verify that the A14 display interface board is working properly. If the external display appears good, then most likely the A15 display is defective. If the external display appears identical to the A15 display, then the problem lies elsewhere. Refer to A14 troubleshooting to determine the cause.
2. Set up a known test pattern (preferably number 5 or 12) and verify all inputs to the display with an oscilloscope. If they appear correct then the display is probably defective. See A14 troubleshooting for specific information.
3. If another working HP 8757D is available, try substituting the display from the working unit.

Should the display become magnetized or if color purity is a problem, try cycling the power several times, leaving the instrument off for at least 15 seconds during each cycle. This will activate the automatic degaussing circuit in the display. If this is insufficient to achieve color purity, a commercially available demagnetizer must be used (either a CRT demagnetizer or a bulk tape eraser can be used). Follow the manufacturer's instructions keeping in mind the following: If one of these items is used, it is *imperative* that, at first, it be placed no closer than 4 inches (10 cm) to the face of the CRT. If this distance is too far to completely demagnetize the CRT, try again at a slightly closer distance until the CRT is demagnetized.



**Applying an excessively strong magnetic field to the CRT face can permanently destroy the CRT resulting in an expensive repair which could have been avoided.**

Like most displays, the CRT can be sensitive to large magnetic fields generated from unshielded line transformers and motors. This usually does not pose a problem if the field is generated with a 60 Hz line frequency, since the vertical scan rate is also 60 Hz. However in countries that use 50 Hz, some 10 Hz jitter may be observed. If this problem is observed, remove the device causing the magnetic field.

During any solid (filled-in) display or test pattern, an extremely thin full-screen horizontal line may be seen about 1/4 screen height from the bottom. This condition is characteristic of the CRT does not indicate any problem.

## A15 Adjustments

### VERTICAL POSITION AND FOCUS

Only vertical position and focus can be adjusted in the field (this includes both customers and service centers). Any other adjustment to the display will *void* the warranty. Vertical positioning and focus are described in Chapter 5, "Adjustments."



## A15 Display Replacement Procedure

### REMOVING THE DISPLAY

Use this procedure to remove the display.

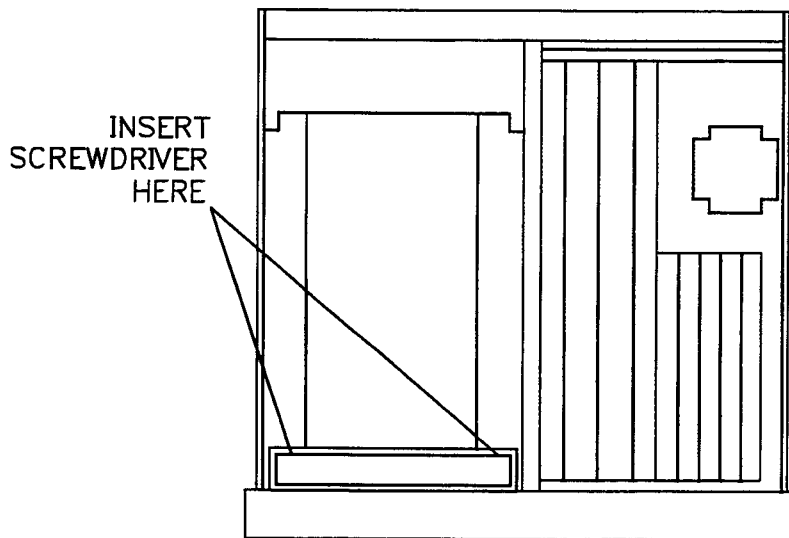
1. Remove the softkey button cover. This is the plastic cover through which the front panel soft keys protrude. Insert a thin flat screwdriver blade, or a fingernail, between it and the glass filter. Be careful not to scratch the glass or its coating. Carefully pull the button cover forward and off.
2. Remove the two screws that are now uncovered. Remove the bezel (with the glass filter) by pulling out the end that is now free and pivoting it around its left edge until it is released. Remove the "rubber" CRT gasket by pulling it away from the CRT.
3. Remove the logger cover by removing the two screws that hold it in place.

### WARNING

**The analyzer must lie on a flat surface. After the next step, the display is free of the analyzer and could slide out, causing both instrument damage and personal injury.**

4. Remove the CRT cover shield by removing the six screws that hold it (and the display) in place. Disconnect the 20 pin ribbon cable that connects the A15 display to the A14 display interface board.
5. Carefully slide the display out of the analyzer.
6. If the display is to be exchanged with a new or rebuilt unit, it will be necessary to remove the spring clip grounding plate attached to the bottom of the display with two screws.

**NOTE:** This plate is *not* considered part of the display and will need to be attached to the new or rebuilt display when it is installed.



*Figure 8-48. Display Shield and CRT (Top View)*

## CLEANING THE DISPLAY AND GLASS FILTER

Because of the high voltage associated with the CRT, minute dust particles may collect around the edges of the CRT and on the inside surface of the glass filter. These particles will dim and diffuse the display image if they are not cleaned off regularly.

**NOTE:** Clean the glass filter with care. Its optical coating, which eliminates reflections, is fragile. Use only a soft cloth and cleaning solutions recommended for coated surfaces. See "Replaceable Parts" for a part number and ordering information for a recommended cleaning solution.

Remove the front bezel to clean the CRT and glass filter. Follow this procedure.

1. Remove the button cover. This is the plastic cover through which the front panel soft keys protrude. Insert a thin flat screwdriver blade, or a fingernail, between it and the glass filter. Be careful not to scratch the glass or its coating. Carefully pull the button cover forward and off.
2. Remove the two screws that are now uncovered.
3. Remove the bezel (with the glass filter) by pulling out the end that is now free and pivoting it around its left edge until it is released.
4. You may be able to clean the CRT and glass filter with the cloth alone or some cleaning solution may be needed. Use the solution sparingly, if required and clean the surfaces gently. Allow the surfaces to dry before reassembling the instrument.

## A16 Rear Panel Video Interface (RGB Interface)

### DESCRIPTION

The A16 RGB interface assembly provides buffering of the video signals from the A14 display interface to an external color monitor. The color monitor must be compatible with the HP 8757D. To be compatible, the monitor must be designed to operate at a horizontal scan rate of 25.5 kHz. In addition, the video input range must be 0 to 0.7 V with a  $-0.3$  V sync on green.

The red and blue buffer amplifier assemblies are identical. Each consists of a one transistor amplifier which provides a 0.7 V level shift and a gain of about one-half when terminated in its characteristic impedance of 75 ohms.

The green buffer is similar to the red and blue buffers but it also includes circuitry to superimpose the sync signal upon the video signals. U2A is used to combine the horizontal and vertical sync signals. Q1 and Q2 provide added current driving/sinking capability. The combined signal is level-shifted by C4 and is superimposed on the green video signal by U1C. The level-shifted sync signal is also used (as an oscillator) to drive a rectifier circuit composed of CR10, CR11, and C6. This provides a nominal  $-2$  V supply which is used by all 3 buffer amplifiers for proper transistor biasing.

L1, C7, C8, and C2 provide power supply filtering.

## A16 Troubleshooting

### BASIC CHECKS

These checks assume that the internal A15 display is properly working. If not, disconnect the A16 interface cable. If the symptom remains, the problem is *not* in the A16 RGB interface. If the symptom is cleared, the problem is probably in U1 or U2 which could affect normal operation of the internal display by loading down one of the five inputs to this board.

If only an external monitor fails to work properly, identify which buffer amplifier is bad by connecting the RGB outputs to an external monitor. Since all three amplifiers are essentially the same, this will allow easy comparisons of the signal levels.

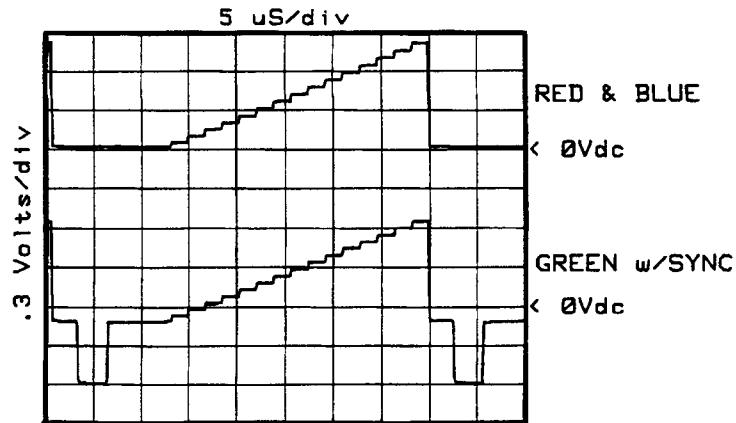
If all three outputs are bad, or the external display fails to sync properly, the problem is most likely in the green amplifier/sync/rectifier circuitry. Verify that about  $-2$  V is present at the trace labeled " $-2V$ ", to provide assurance that most of the board is functioning properly.

### R, G, B BUFFER AMPLIFIERS

Operation of the red and blue buffer amplifiers is extremely simple. The input level voltage range is a nominal 0.6 to 2.3 V. The output level should be a nominal 0 to 0.8 V when terminated with a 75 ohm load. The green buffer amplifier should have a  $-0.3$  V (or greater) sync signal superimposed on it. See Figure 8-49 for a typical output during the 16-step gray scale test pattern when terminated in 75 ohms.

### SYNC/RECTIFIER

Verify that  $-2$  V is present at the trace labeled " $-2V$ ." If not, trace the combined horizontal/vertical sync back to the input. Horizontal sync is 25.5 kHz while vertical sync is 60 Hz. The collectors of Q1 and Q2 should swing from nearly +5 V to near ground. Verify the combined sync is being superimposed on the green video signal and that it is at least  $-0.3$  V in amplitude. The actual DC level of the entire green waveform may shift depending upon the video signal. This should not matter since most monitors are AC coupled. See Figure 8-49.



Rear panel video outputs (into 75 ohms) during 16-step gray scale test pattern

Figure 8-49. Typical RGB Video Output

Replaceable Parts List for A16 Assembly (1 of 1)

Reference Designation	HP Part Number	Qty	Description	Mfr Code	Mfr Part Number
A16	08757-60077	1	BD AY-R P VIDEO	28480	08757-60077
A16C1	0160-4801	1	CAP-FXD 100pF ±5% 100 V CER COG	02010	SA102A101JAAH
A16C2	0180-3813	1	CAP-FXD 10uF ±10% 10 V TA	04200	299D106X9010BB1
A16C3	0160-4084	1	CAP-FXD 0.1uF ±20% 50 V CER X7R	02010	SR215C104MAAH
A16C4	0180-3813	1	CAP-FXD 10uF ±10% 10 V TA	04200	299D106X9010BB1
A16C5	0160-4084	1	CAP-FXD 0.1uF ±20% 50 V CER X7R	02010	SR215C104MAAH
A16C6	0180-3849	1	CAP-FXD 47uF ±10% 10 V TA	04200	299D476X9010DB1
A16C7-C9	0160-4832	1	CAP-FXD 0.01uF ±10% 100 V CER X7R	02010	SA101C103KAAH
A16CR1 - CR11	1901-0050	11	DIODE-SWITCHING 80V 200MA 2NS DO-35	03406	
A16J1-J3	1250-1453	1	CONNECTOR-RF BNC RCPT PC-W-STDFS 50-OHM	03316	28JR175-3
A16L1	9140-0261	1	INDUCTOR RF-CH-MLD 100NH ±5%	03273	15M100J
A16Q1	1853-0281	1	TRANSISTOR PNP 2N2907A SI TO-18 PD=400MW	02037	2N2907A
A16Q2	1854-0477	1	TRANSISTOR NPN 2N2222A SI TO-18 PD=500MW	02037	2N2222A
A16R1-R3	0698-3441	1	RESISTOR 215 ±1% .125W TF TC=0±100	05524	
A16R4-R6	0698-3430	1	RESISTOR 21.5 ±1% .125W TF TC=0±100	05524	
A16R7-R8	0757-0394	1	RESISTOR 51.1 ±1% .125W TF TC=0±100	05524	
A16R9	0757-0400	1	RESISTOR 90.9 ±1% .125W TF TC=0±100	05524	
A16R10	0757-0394	1	RESISTOR 51.1 ±1% .125W TF TC=0±100	05524	
A16R11	0757-0346	1	RESISTOR 10 ±1% .125W TF TC=0±100	05524	
A16R12	0757-0279	1	RESISTOR 3.16K ±1% .125W TF TC=0±100	05524	
A16R13	0757-0280	1	RESISTOR 1K ±1% .125W TF TC=0±100	05524	
A16R14-R15	0757-0279	1	RESISTOR 3.16K ±1% .125W TF TC=0±100	05524	
A16R16	0698-3132	1	RESISTOR 261 ±1% .125W TF TC=0±100	05524	
A16R17	0757-0346	1	RESISTOR 10 ±1% .125W TF TC=0±100	05524	
A16U1	1858-0077	1	TRANSISTOR ARRAY 14-PIN PLSTC TO-116	02037	MPQ2222P
A16U2	1820-2656	1	IC GATE TTL/ALS NAND QUAD 2-INP	01698	SN74ALS00AN
A16W1	08757-60083	1	CONN AY-RP VIDEO		

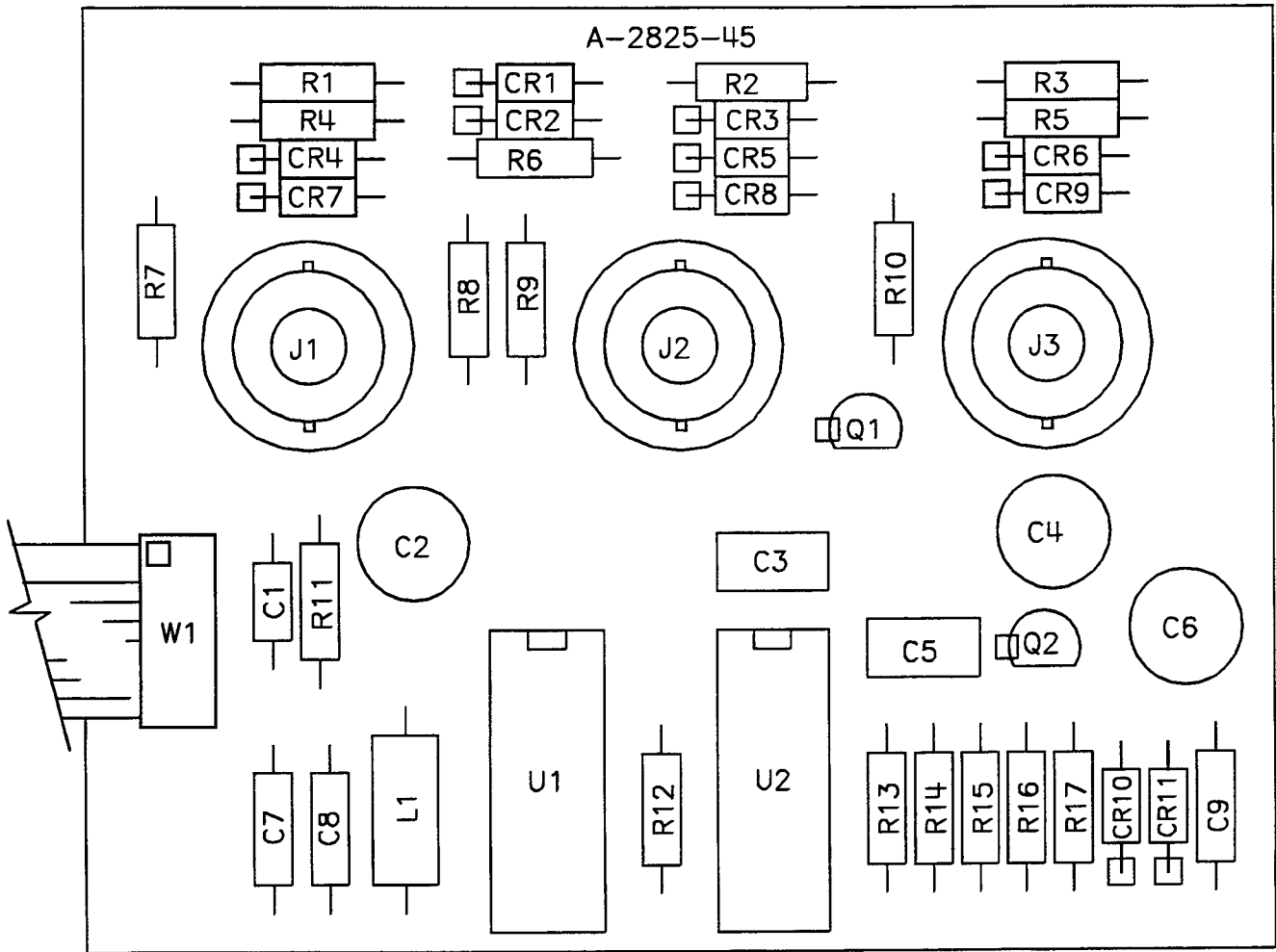
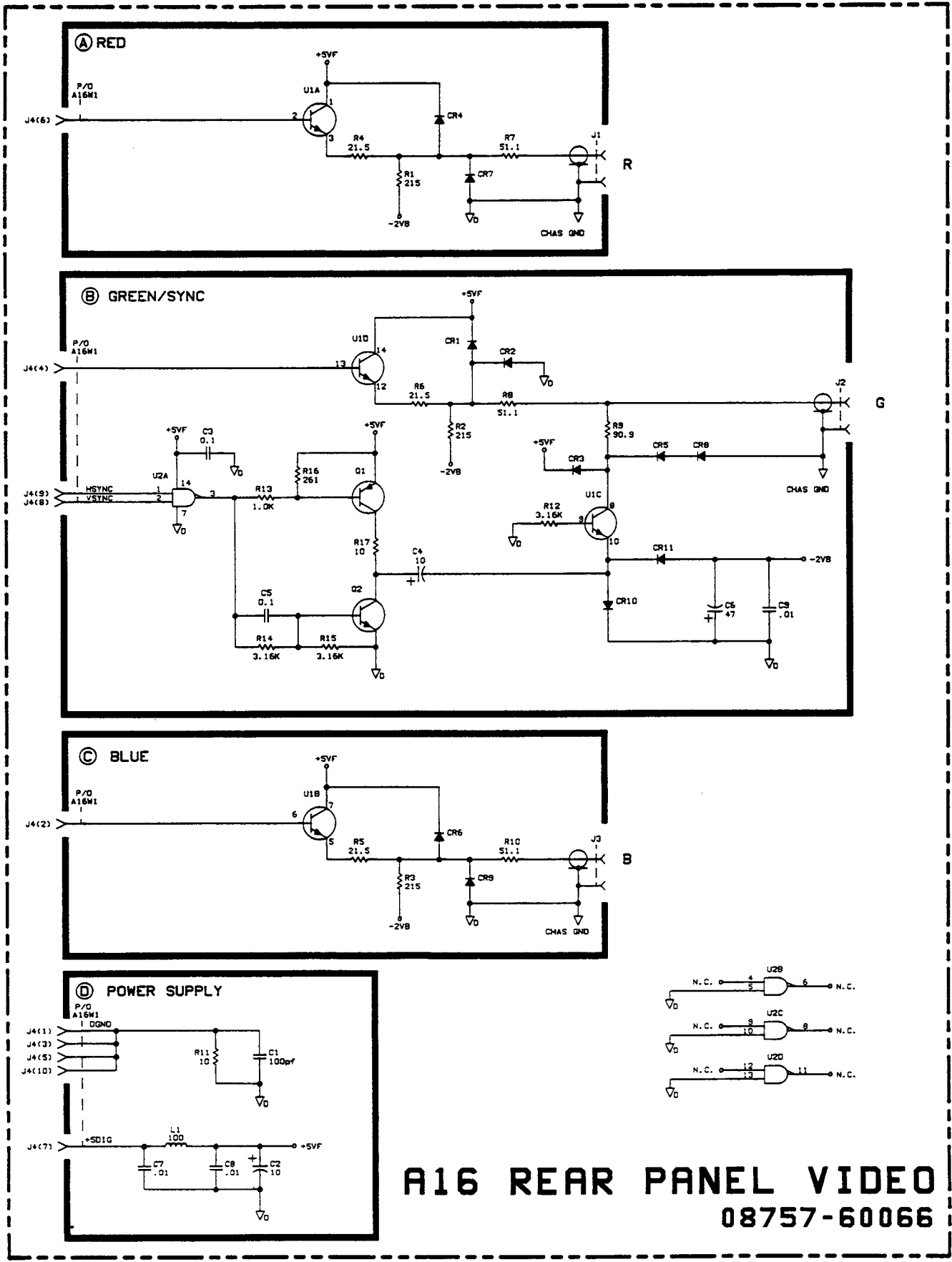


Figure 8-50. A16 Component Locations Diagram



A16 RGB Interface Schematic Diagram





# HP 8757D Index

## Numbers

8757 Interface, 4–7

## A

A1 Front Panel/A2 Front Panel Interface, 8–31  
Address Decoder Lines, 8–39

A11 Motherboard and A13 Rear Panel, 8–169  
Wiring List, 8–169

A12 Power Supply, 8–153  
Power Supply and Component Illustrations, 8–165

A14 Display Interface Board, 8–181  
Adjustments, 8–186  
Diagnostic Tests, 8–186  
Test Pattern Summary, 8–188

A15 Display, 8–213  
Adjustments, 8–214

A3 Central Processing Unit (CPU), 8–49  
Address Decoder Lines, 8–67  
Primary Error Codes, 8–58

A4 Analog-to-Digital Converter (ADC), 8–75  
Assembly Location, 5–8  
Sweep-Related Waveforms, 8–98

A5 Cal/Mod Board Assembly (Opt. 002 only), 8–113

A5 Modulator Driver (Standard Instrument only), 8–111

A5 Replaceable Parts, 8–115

A6 HP-IB Assembly, 8–121  
Address Decoder Lines, 8–127  
Line Activity, 8–125

A7/A8/A9/A10 Log Amplifiers, 8–133  
Pin U10 Versus Power Level, 8–138

Abbreviations, 6–4

ADC BIT CHECK softkey, 8–83

ADC MEAS softkey, 8–83

Address Decoder Lines, A3 CPU, 8–67

Address Decoder/Reset, 8–31

ADDRESS key, 8–13

Adjustment Controls, Location of, 5–2

Adjustments, 5–1  
Background, 5–9  
Controls, 5–3  
Display Intensity, 5–9  
Focus, 5–12  
Minimum Intensity, 5–11  
Adjustment Set-up, 5–11  
Nominal Intensity, 5–10  
Adjustment Set-up, 5–10  
Power Supply, 5–4  
Related, 5–2  
Sweep DAC Gain, 5–7  
Vertical Position, 5–12

Analog Accuracy, Analog-to-Digital Conversion and, 8–24

Analog-to-Digital (ADC) Circuit Description, 8–19

Analog-to-Digital Conversion and Analog Accuracy, 8–24

## B

Background Adjustments, 5–9

BCKGRND ADJUST softkey, 8–186

BCKGRND RAMP softkey, 8–190

## C

Calibration Constants and Checksum Errors, 8–9

Central Processing Unit (CPU) Circuit Description, 8–19

CHANNEL VOLTS softkey, 8–87

CHANV DETDAC, 8–89

CHANV LOGGER, 8–89

CHANV OTHER, 8–89

Checksum Errors, Calibration Constants and, 8–9

Circuit Description  
A1 Front Panel/A2 Front Panel Interface, 8–31  
A12 Power Supply, 8–153  
A14 Display Interface Board, 8–181  
A15 Display, 8–213  
A16 Rear Panel Video Interface (RGB), 8–217

A3 Central Processing Unit (CPU), 8–49

A4 Analog-to-Digital Converter (ADC), 8–75

A5 CAL/MOD Board Assembly (Opt. 002 only), 8–113

A5 Modulator Driver (Standard Instrument only), 8–111

A6 HP-IB Assembly, 8–121

A7/A8/A9/A10 Log Amplifiers, 8–133

Analog-to-Digital Converter (ADC)(A4), 8–19

Central Processing Unit (CPU)(A3), 8–19  
Display (A15), 8–20  
Display Interface (A14), 8–20  
Front Panel (A1/A2), 8–20  
HP-IB (A6), 8–20  
Log Amplifiers (A7,A8,A9,A10), 8–18  
Modulator Driver (A5), 8–21  
Power Supply (A12), 8–21  
RGB Interface (A16), 8–20

Circuits Not Checked by Self-Tests, 8–94

Cleaning the Display and Glass Filter, 8–216

Component Location Diagram, A11 Motherboard, 8–176

Component Location Diagrams  
A1 Front Panel, 8–44  
A13 Rear Panel, 8–178  
A14 Display Interface, 8–208  
A16 Rear Panel Video Interface, 8–220  
A2 Front Panel Interface, 8–44  
A3 Central Processing Unit, 8–72  
A4 Analog-to-Digital Converter, 8–106  
A5 Mod/Cal Assembly (Option 002), 8–118  
A5 Modulator Drive (Standard only), 8–116  
A6 HP-IB Assembly, 8–130  
A7/A8/A9/A10 Log Amplifiers, 8–150

Control Registers, 8–33

CPU Read/Write Cycle Waveform, 8–55

## D

DAC BIT CHECK, 8–83

DAC Gain Adjustment Locations, Sweep, 5–8

DAC Gain Adjustment, Sweep, 5–7  
 DAC Waveforms During A4 Ramp Test, 8–87  
 Data Acquisition and Sweep Comparators, 8–23  
 DATA READY, 8–90  
 Data Ready Failure Chart, 8–90  
 DET CONTROL, 8–83  
 Detector Bias/Control, 8–33  
 Device Reference Designator, 8–192  
 Diagnostic Tests  
   A14 Display Interface, 8–186  
   A3 Central Processing Unit (CPU), 8–54  
   A4 ADC, 8–83  
 Diagnostic Tests, Forced, 8–8  
 Diagnostic Tests, Operator–Initiated, 8–12, 8–16  
 Display (A15) Circuit Description, 8–20  
 Display Intensity Adjustments, 5–9  
 Display Interface (A14) Circuit Description, 8–20  
 Display Replacement Procedure, 8–215  
 DISPLAY: TEST softkey, 8–190  
 Dynamic Power Accuracy, 4–4

## E

EEPROM Clock Generator, 8–33  
 EEPROM Data Select, 8–33  
 EEPROM TEST Softkey, 8–54  
 Error Code Description, 8–195  
 Error Code Summary, 8–6  
 Error Codes, 8–5  
 Error Codes, Self–Test and, 8–22  
 Error Messages, Other, 8–10  
 Error Messages, Power Calibration, 8–10  
 Exchange Assemblies, Restored, 6–2  
 Exchange Program, Module, 6–3

## F

Focus Adjustment, Vertical Position and, 5–12  
 Forced Diagnostic Tests, 8–8, 8–191  
 Free Run Test, 8–65  
 Frequency Accuracy, 4–6  
 Front Panel (A1/A2) Circuit Description, 8–20  
 Front Panel Removal Procedure, 8–38  
 Front Panel Status/Interrupt, 8–33

## G

Glass Filter, Cleaning the Display and, 8–216

## H

Hex Data Rotate Waveforms, 8–15  
 Hexadecimal Equivalents, 8–13  
 Hexadecimal Tests, 8–12  
 HP Interface Bus, 4–7  
 HP–IB, 8–25  
 HP–IB (A6) Circuit Description, 8–20

## I

Instrument Bus Cycle, 8–126  
 Instrument Bus Failures, 8–126  
 Instrument Verify, 8–8  
 Interrupt Levels, 8–64  
 Interrupt, Front Panel Status/, 8–33  
 INTNSTY RAMP softkey, 8–190  
 INTRPT Softkey, 8–55

## K

Keyboard Interface, 8–32

## L

Line Power and Power Supplies, 8–22  
 Log Amplifiers Circuit Description, 8–18

## M

Manufacturer's Code, 6–6  
 Microprocessor, 8–50  
 MINIMUM INT ADJ softkey, 8–187  
 Minimum Intensity Adjustment, 5–11  
 MOD ON OFF softkey, 8–112  
 Modulator Drive, 4–5  
 Modulator Driver (A5) Circuit Description, 8–21  
 Module Exchange Program, 6–3  
 Motherboard Wiring List, 8–169

## N

NOMINAL INT ADJ softkey, 8–187  
 Nominal Intensity Adjustment, 5–10

## O

Operator–Initiated Diagnostic Tests, 8–12, 8–16  
 Option 002, Performance Test, 4–9  
 Overall Instrument Description, 8–18  
 Overall Instrument Troubleshooting, 8–21

## P

Parts List Organization, 6–1  
 Performance Tests, 4–1  
   8757 Interface, 4–7  
   Dynamic Power Accuracy, 4–4  
     Alternative, 4–4  
   Frequency Accuracy, 4–6  
   HP Interface Bus, 4–7  
   Modulator Drive, 4–5  
   Option 002 only, 4–9  
   Record Card, 4–8  
   Symmetry, 4–6  
 Pin–Outs  
   A1 Front Panel, 8–40  
   A14 Display Interface, 8–203  
   A2 Front Panel Interface, 8–40  
   A3 Central Processing Unit, 8–68  
   A4 Analog–to–Digital Converter, 8–99  
   A5 Modulator Drive, 8–114  
   A6 HP–IB Assembly, 8–128  
   A7/A8/A9/A10 Log Amplifiers, 8–140

Power Calibration Error Messages, 8–10  
Power Supplies, Line Power and, 8–22  
Power Supply (A12) Circuit Description, 8–21  
Power Supply Adjustments, 5–4  
Power Supply Voltages and Tolerances, 8–160  
Primary Error Codes, 8–58

## R

RAM TEST Softkey, 8–54  
RAMP softkey, 8–86  
READ DATA, 8–91  
Read Data Tests, 8–91  
READ key, 8–14  
READ STATUS Softkey, 8–55  
Real Time Clock, 8–31  
Recommended Test Equipment, 4–2  
Reference Designations, 6–4  
Related Adjustments, 5–2  
Replaceable Parts, 6–1  
    Abbreviations, 6–4  
    Manufacturer's Code, 6–6  
    Ordering Information, 6–1  
    Reference Designations, 6–4  
Restored Exchange Assemblies, 6–2  
RGB Interface (A16) Circuit Description, 8–20  
ROM Signatures, A3 CPU, 8–62  
ROTATE test, 8–15  
RPG Interface, 8–32

## S

Safety Considerations, 5–1

Self Test Summary, 8–6  
Self–Test, 4–3  
Self–Test and Error Codes, 8–22  
Self–Test Sequence, 8–7  
Self–Tests, A3 CPU, 8–57  
Self–tests, Notes on, 8–11

### Softkeys

ADC BIT CHECK, 8–83  
ADC MEAS, 8–83  
BCKGRND ADJUST, 8–186  
BCKGRND RAMP, 8–190  
CHANNEL VOLTS, 8–87  
CHANV DETDAC, 8–89  
CHANV LOGGER, 8–89  
CHANV OTHERS, 8–89  
DAC BIT CHECK, 8–83  
DATA READY, 8–90  
DET CONTROL, 8–83  
DISPLAY: TEST, 8–190  
EEPROM TEST, 8–54  
INTNSTY RAMP, 8–190  
INTRPT, 8–55  
MINIMUM INT ADJ, 8–187  
MOD ON OFF, 8–112  
NOMINAL INT ADJ, 8–187  
RAM TEST, 8–54  
RAMP, 8–86  
READ DATA, 8–91  
READ STATUS, 8–55  
SWEEP COMPARE, 8–85, 8–95  
TEST PATTERN, 8–187  
TIMER, 8–54

Sweep Comparators, Data Acquisition and, 8–23  
Sweep Compare Failure Chart, 8–86  
SWEEP COMPARE softkey, 8–85, 8–95  
Sweep DAC Gain Adjustment, 5–7  
Sweep DAC Gain Adjustment Locations, 5–8  
Symmetry, Frequency Accuracy and, 4–6

## T

Test Equipment, Recommended, 4–2  
TEST PATTERN softkey, 8–187  
Test Patterns, Description of, 8–188  
Test Points, Location of, 5–2  
TIMER Softkey, 8–54  
Timing of the A4 Data Loop, 8–92  
Troubleshooting, 8–1  
    A1 Front Panel/A2 Front Panel Interface, 8–36  
    A12 Power Supply, 8–159  
    A14 Display Interface, 8–194  
    A15 Display, 8–214  
    A16 Rear Panel Video Interface, 8–218  
    A3 Central Processing Unit (CPU), 8–57  
    A4 Analog–to–Digital Converter (ADC), 8–93  
    A5 Modulator Drive (Standard Instrument only), 8–112  
    A6 HP–IB Assembly, 8–124  
    A7/A8/A9/A10 Log Amplifiers, 8–136  
Troubleshooting, Overall Instrument, 8–21

## V

Vertical Position Adjustment Control, 5–12  
Vertical Position and Focus Adjustment, 5–12  
VRAM Error Code, 8–192

## W

W1–4 Detector Interface Cable Schematic, 8–41  
WRITE key, 8–14

